

INDEX
BOARD OF TRANSPORTATION MEETING
May 4, 2023

	<u>Page No.</u>
Call to Order	4
Ethics Statement	4
Pledge of Allegiance	5
Approval – Minutes of the April 5-6, 2023, Board Meeting	5
Road, Bridge, and Ferry Naming Honorary Designations	5
Secretary’s Remarks	6
 <u>INFORMATION AND DELEGATED AUTHORITY ITEMS</u>	
Delegated Authority Items	
Approval – (Item C) Award of Highway Construction Contracts from April 2023 Letting	12
Approval – (Item D) Award of Contracts to Private Firms for Engineering Services	20
Approval – (Item E) Funds for Secondary Road Improvement Projects – Highway Fund and Highway Trust Fund	35
Approval – (Item H) Funds for Division-wide Small Construction, Statewide Contingency, Public Access, and Economic Development	38
Approval – (Item L) Funds for Specific Spot Safety Improvement Projects	44
 <u>ACTION</u>	
Project Items	
Approval – (Item G) Additions, Abandonments, and Road Name Changes to State Secondary Road System	47
Approval – (Item I-1) Public Transportation	49
Approval – (Item I-2) Rail Program	59
Approval – (Item I-3) Bicycle and Pedestrian	61
Approval – (Item I-4) Aviation	62
Approval – (Item K) North Carolina Highway Trust Funds	63

	<u>Page No.</u>
Approval – (Item M) Funds for Specific Federal-Aid Projects	81
Approval – (Item N) Revisions to the 2020-2029 STIP	111
Approval – (Item O) Municipal and Special Agreements	136
Approval – (Item P) Municipal Street System Changes	150
Approval – (Item R) Right of Way Resolutions and Ordinances	152
Approval – (Item S) Maintenance Allocations	166
Approval – Consideration of the Division of Mitigation Services (DMS) Biennial Budget	173
Committee Reports	173
Other Business	179
Adjournment	180
Attachments	181

BOARD OF TRANSPORTATION MEETING

May 4, 2023

Committee Meetings

All Committee Reports are located at the end of this document.

Full Board Work Session

Wednesday, May 3, 2023

Chairman Fox welcomed the members of the Board to the meeting located in the Board Room. He welcomed the new Board Member, Senator Kathryn Harrington, who will be an at-large member representing Division 12. He mentioned that Senator Harrington recently retired from the Senate but that she served the 43rd district from 2011-2022. She was elected Senate Majority Leader following the 2020 election and was the first woman in North Carolina to hold that position. Chairman Fox shared that Senator Harrington helped write the STI laws and that she brings a great deal of transportation experience to the Board.

Roll Call

Chairman Fox conducted a roll call of members with the following members present in the meeting: Chairman Fox, Vice Chair Perkins, Board Member Moran, Board Member Alcoke, Board Member Mitchell, Board Member Jordan, Board Member Hunt, Board Member Mathis, Board Member Molamphy, Board Member Lathrop, Board Member Phillips, Board Member Lail, Board Member Harrington, Board Member Clarke, Board Member Cody and Board Member McGrady.

The following members were present via teams: Board Member Daughtry and Board Member Rosenburgh.

The following members were absent: Board Member Zimmer and Board Member Wells.

Declaration of Quorum

Following the roll call, Chairman Fox stated the members participating constituted a quorum of the Board and he declared the meeting open.

Call to Order

Chairman Fox called the full board Work Session to order on Wednesday, May 3, 2023.

Ethics Statement

Chairman Fox read the Ethics Statement advising all members of the Board that may have any conflict of interest, or appearance of conflict, to refrain from participation in that item and to file the proper paperwork with the Secretary to the Board of Transportation.

Chairman Fox read, "In accordance with the State Government Ethics Act, Executive Order No. 2 issued on January 12, 2009, and N. C. G. S. §143B-350, it is the duty of every Board member to avoid both conflicts of interest and appearances of conflict. "To comply with this statement and the State Ethics Law, I ask whether any Board member has a known conflict of interest or appearance of conflict with respect to any matters coming before the Board today."

"If so, please identify the conflict or appearance of conflict when the item appears on the agenda for consideration, refrain from any undue participation in the particular matter involved and sign before our notary the Declaration that has been provided to you for such purpose."

Innovative Technology and Product Awareness

Chairman Fox noted that a copy of this month's Innovative Technology and Product Awareness update was provided to members of the Board for review and posted on the Board's website for review.

Legislative Update

Chairman Fox welcomed Leigh Jackson, Legislative Affairs Director, to present a legislative update.

Prioritization 7.0 (P7.0)

Chairman Fox welcomed Brian Wert, Senior Transportation Engineer, to present an update on Prioritization 7.0 (P7.0).

Presentation is attached at the end of this document.

2024-2033 STIP Update

Chairman Fox talked through the STIP update that was provided by Leigh Wing. Chairman Fox said that last month, Kevin Lacy presented updates and needed changes to the 2024-2033 STIP since the draft was released last August to ensure fiscal constraint. He reminded the Board Members that a spreadsheet of the projects that go through the prioritization scoring highlighting those changes was provided to them. He also mentioned that a full 2024-2033 STIP spreadsheet will be coming to them by the end of week. This document will include all projects in the STIP – not just projects going through scoring. It will have all alternate criteria projects (things like interstate maintenance, bridge, and safety projects) as well as local federally funded projects. This is the document that staff will be asking us to adopt at our June Board meeting.

Highway Maintenance Improvement Project (HMIP) Update

Chairman Fox welcomed Kristin Barnes, Director of Highway Operations, to present an update on the Highway Maintenance Improvement Project. The ask for the Board is to review the plans and formally approve the project for the next 5 years at the June Board meeting.

Presentation is attached at the end of this document.

Consideration of the DMS Biennial Budget

Chairman Fox reminded the Board that they would be voting on the DMS Biennial Budget at the Board Meeting tomorrow, May 4, 2023.

Committees

Chairman Fox announced that afternoon committees would convene following the Work Session. The Economic Development and Intergovernmental Relations (EDIR) Committee will be held in the Board Room (Room 150). The Division of Motor Vehicles (DMV) Committee will meet in the EIC. The ATC Committee will meet in the Board Room (Room 150). The Workforce will meet in the EIC.

Adjournment

Chairman Fox asked if there were any additional items for discussion. He stated hearing none he would accept a motion to adjourn the meeting. A motion was made by Board Member Clarke and seconded by Board Member Mitchell. Chairman Fox stated the motion passed unanimously.

Chairman Fox adjourned the meeting.

Full Board Work Session

Thursday, May 4, 2023

Chairman Fox welcomed the members of the Board to the meeting located in the Board Room.

Roll Call

Chairman Fox conducted a roll call of members with the following members present in the meeting: Chairman Fox, Vice Chair Perkins, Board Member Moran, Board Member Alcoke, Board Member Mitchell, Board Member Jordan, Board Member Hunt, Board Member Mathis, Board Member Molamphy, Board Member Phillips, Board Member Lail, Board Member Harrington, Board Member Clarke, Board Member Cody, and Board Member McGrady.

The following members were present via teams: Board Member Lathrop and Board Member Rosenburgh.

The following members were absent: Board Member Zimmer, Board Member Daughtry, and Board Member Wells.

Declaration of Quorum

Following the roll call, Chairman Fox stated the members participating constituted a quorum of the Board and he declared the meeting open.

Call to Order

Chairman Fox called the full board meeting to order on Thursday, May 4, 2023.

Ethics Statement

Chairman Fox read the Ethics Statement advising all members of the Board that may have any conflict of interest, or appearance of conflict, to refrain from participation in that item and to file the proper paperwork with the Secretary to the Board of Transportation.

Chairman Fox read, "In accordance with the State Government Ethics Act, Executive Order No. 2 issued on January 12, 2009, and N. C. G. S. §143B-350, it is the duty of every Board member to avoid both conflicts of interest and appearances of conflict. "To comply with this statement and the State Ethics Law, I ask whether any Board member has a known conflict of interest or appearance of conflict with respect to any matters coming before the Board today."

“If so, please identify the conflict or appearance of conflict when the item appears on the agenda for consideration, refrain from any undue participation in the particular matter involved and sign before our notary the Declaration that has been provided to you for such purpose.”

Pledge of Allegiance

Chairman Fox invited Secretary Boyette to lead the members of the Board and all other meeting attendees in the Pledge of Allegiance.

Approval – April 5-6, 2023, Meeting Minutes

Chairman Fox stated the meeting minutes from April 5-6, 2023, were distributed for review prior to the meeting. Chairman Fox stated if there are no additions or corrections, he would accept a motion to approve the April 5-6, 2023, meeting minutes of the Board of Transportation. A motion was made by Board Member Clarke and a second by Board Member McGrady. The minutes were approved unanimously by members of the Board.

Chairman Fox stated the motion passed.

Road, Bridge, and Ferry Naming Honorary Designations

Board Member Valerie Jordan read the resolution for the North Carolina Central University 2022 Men’s Football National Champions naming located in Division 5. The reading was accepted as a motion by Board Member Jordan and a second by Board Member Perkins. The motion passed unanimously by the members of the Board.

Board Member Valerie Jordan read the resolution for the Coach K Highway naming located in Division 5. The reading was accepted as a motion by Board Member Jordan and a second by Board Member Cody. The motion passed unanimously by the members of the Board.

Board Member Valerie Jordan read the resolution for the Officer Ryan A. Hayworth Bridge naming located in Division 5. The reading was accepted as a motion by Board Member Jordan and a second by Board Member Moran. The motion passed unanimously by the members of the Board.

Board Member Melvin Mitchell read the resolution for the Rev. Thomas L. Walker Bridge naming located in Division 4. The reading was accepted as a motion by Board Member Mitchell and a second by Board Member Perkins. The motion passed unanimously by the members of the Board.

Secretary's Remarks

Secretary Boyette started off by thanking and welcoming the newest Board Member, Kathryn Harrington. He emphasized how much transportation knowledge she brings to the Board and that everyone is looking forward to it. The Secretary also announced that Vice Chairman Andy Perkins retired from NC A&T this past week. He thanked Vice Chairman Perkins for everything that he does and congratulated him on his retirement.

Secretary Boyette took a moment to send condolences to the family of Claude CJ Bryant. Mr. Bryant was an employee of a partner of the department, ST Wooten. He was killed in an active work zone Wednesday morning. The Secretary stated that it is another senseless act, and he will continue to talk about our work zones and safety. He encouraged everyone to please pay attention and to slow down. He reminded everyone that these workers are out there for us and that they are trying to do everything they can to make sure our traffic is not impeded. He mentioned that these acts can be avoided if everyone just pays attention.

Secretary Boyette shared some good news from the Office of the State Auditor. There were no findings in our performance audit for the SFY 2022 Cash Spending Plan. He thanked the Auditor and their staff for their professionalism in making sure that the department is strengthening our financial issues and helping us be good stewards to the taxpayers' dollars. He also thanked Stephanie King, Chief Financial Officer, and her team for all their hard work.

Secretary Boyette announced that the department was recognized once again as a military friendly employer. The VETS Indexes has named NCDOT as the 2023 three star military friendly employer. He explained how this is another recruitment commitment in hiring, retaining, developing, and supporting our veterans. He expressed how the department is proud to support our nation's heroes.

Secretary Boyette stated that we had some recognition from the WTS NC Triangle Chapter. The organization named our own Julie White, Deputy Secretary for Multimodal Transportation, the 2023 Woman of the Year. He explained that Julie is very passionate about transportation and that she is a great mentor and has seen her help people grow. He expressed his appreciation for what she brings to our team, especially for women and minorities. He explained that Julie does a great job of encouraging women to jump in engineering and to try new things. He also thanked Ryan Brumfield, Director of Integrated Mobility Division, and his team. The Integrated Mobility Division was also recognized for their S line development study.

Secretary Boyette announced that the department ended the Spring Litter Sweep over the weekend. The contract teams of volunteers and NCDOT employees collected a little over

600,000 pounds of trash. He encouraged everyone not to litter because the less we have to clean, means less money that we have to spend. This year to date, the department has collected more than 3.5 million pounds of trash statewide.

Secretary Boyette shared that our rail ridership is continuing to do well. January, February, and March all broke monthly records. We were about 30% over our 2019 numbers and about 50% over last quarters' ridership. The Secretary also announced that we are adding an additional line to be able to pick up even more traffic. This line will be available in July 2023. To buy tickets or to learn more, go to NCbyTrain.org.

Secretary Boyette shared that the department held the annual model bridge competition last Friday. This event encourages middle and high school students to use their engineering skills. This event is also a way for the department to start recruiting early. Photos from this event are available to view online.

Secretary Boyette announced that the department honored the winner of our annual Aviation Art Contest yesterday. They were presented with awards and were able to get a picture with Governor Cooper at the Executive Mansion. The Secretary mentioned how much talent that we have in North Carolina and that the photos of their artwork are also available to view online.

Secretary Boyette shared some good news from the Office of the HBCU Outreach. Five members of the HBCU Outreach Fellows program have accepted full time employment. Some are staying with the department and some in other agencies. Khalil McGruder will be staying with NCDOT and working in Division 8. Kayla Pope will also be staying with NCDOT and working with Safety & Risk Management. Jeff Hart will be working at the NC Governor's Office as a Policy Advisor. Deborah Walker will be working at the NC Justice Center. Onunga Ooro will be working at US EPA. This is proof that the work the department is putting into this program is working. He shared that there are still plenty of job opportunities out there for transportation. He encouraged those looking for a job to visit ncdot.gov/careers.

Secretary Boyette spoke about our staff response. There are many instances where issues arise after hours and employees help when they are needed. For example, in Smithfield, there was a was a traffic signal that an over height vehicle struck and took down. There was another incident in Bladen County where contract crews and other partners worked overnight to make emergency repairs underneath the U.S. 701 Bridge over the Cape Fear River that they were able to fix in less than 24-48 hours. He wanted to share these efforts because these are the kinds of acts that people don't get to see and that are not talked about enough. He wanted to take a minute to thank every employee that responds to these types of incidents.

Secretary Boyette then shared a video with the Board of an employee and his family who helped a refugee family from Ukraine. He thanked that employee and the Communications staff for putting together the video that was shared with the Board and attending staff.

Lastly, Secretary Boyette presented the Karen Collette Trailblazer Award. This award was established in 2019 in honor the state's first female Division Engineer, Kareen Collette. This award recognizes an employee who has unprecedented career accomplishments, outstanding contributions, identifies, and implements innovative, measurable, and lasting changes that positively affect our department. The recipient this year is someone that who has blazed her own trail as the department's first permanent female Chief Financial Officer. She has held several positions over her 30-year career with the department prior to retiring several years ago. She is a great role model, the mentor to many, especially many of our current and former female employees who have looked up to her. Secretary Boyette then shared a quote from her nomination letter, "In 2020, she was asked to return DOT as the CFO to lead the department through some financial issues and build back trust with partners, stakeholders and other agencies through the challenges and moments of adversity she has been and continues to be, a sacrificial leader that inspires and motivates others to take action to stay the course, to be respected, and not only for extensive knowledge and accumulated over a long career with the department, but also for the way in which she connects and cares about others". This year's recipient for the Karen Collette Trailblazer Award goes to Stephanie King. She shared her thanks and some kind words in front of the Board.

INFORMATION AND DELEGATED AUTHORITY ITEMS

Delegated Authority

Chairman Fox stated that items C, D, E, H, and L are delegated to the Secretary and require no formal action by the Board.

Item C:

Chairman Fox stated for the record for Item C all projects were awarded by the Secretary to the low bidder.

ACTION

Action – Project Items

Chairman Fox asked members of the Board to announce any recusals to the action items within the presented project items. Recusals made by members of the Board on project items are noted below.

Chairman Fox reminded any member of the board that made a recusal to email the completed recusal form to Marilyn McHilse, Board Secretary. He also mentioned that board members sign and email or return the Ethics Declaration.

Chairman Fox invited a motion to approve the project items as presented. A motion was made by Board Member Clarke and a second by Board Member Mitchell to approve all projects for G, I, K, M, N, O, P, and R. Chairman Fox conducted a roll call vote of participating members, and the project items were approved unanimously by members of the Board.

Chairman Fox stated the motion passed.

Recusals

Board Member Harrington recused herself from voting since this was her first Board meeting.

Board Member Lathrop recused himself from voting on the following projects:

- **Item I-1 – Mecklenburg County, 24-08-102**

CITY OF CHARLOTTE. FY24 Metropolitan Planning Organization. The City of Charlotte, operating as the Charlotte Regional Transportation Planning Organization, is requesting funds for transit planning in the MPO area. Application Number: 1000017709

- **Item I-1 – Mecklenburg County, 24-RS-102**

CITY OF CHARLOTTE. FY24 Rideshare. City of Charlotte will use these funds to support transportation demand management administration and/or program elements in the Charlotte area. Application Number: 1000017915

- **Item O – Mecklenburg County, 45969.3.1**

This Project consists of the construction of Four Mile Creek Greenway Crossing under SR 3448 (South Trade Street). The Department is constructing the Department and the County is participating with Federal STBG-DA funds and non-federal match. This supplemental agreement is to provide an additional \$344,000 (80%) for the construction phase. The County shall provide the 20 % non-federal match of \$86,000 and additional local overmatch funding of \$29,000 for a total of \$115,000. The County shall pay all costs that exceed the total available funding of \$3,040,800.

- **Item O – Cabarrus County, M-0549E**

Pulte Home Company, LLC. This Crossing Improvement Construction Reimbursement Agreement provides for reimbursement to the Department from the Developer for all costs by Norfolk Southern Railway for the at-grade crossing improvement and the addition of sidewalks at Norfolk Southern Railway tracks and SR 1304 - Roberta Road (Crossing 736 256N, MP 360.85) in conjunction with the Developer Project. Reimbursement shall be for 100% of the Department's costs to coordinate the construction with Norfolk Southern Railway. The total estimated cost to the Developer is \$197,850. There will be no cost to the Department for this Agreement.

Chairman Fox recused himself from voting on the following projects:

- **Item R-8 – Guilford County, U-2524 BA**

Parcel 504A, Greensboro Western Loop (Combine with I- 22001G & U-2524BB) From South of I-40 to North of SR-2147 (West Friendly Avenue) Guilford County. Conveyance of an approximate 0.500-acre area comprised of one (1) C-class residue, having a value of \$16,500.00 to Billy R. Ratledge, Trustee Ratledge Family Trust for the highest offer amount of \$14,850.00; no additional fees required. This residue was acquired for \$15,164.00 in 2000.

- **Item R-8 – Guilford County, U-2524 BA**

Parcel 504A, Greensboro Western Loop (Combine with I- 22001G & U-2524BB) From South of I-40 to North of SR-2147 (West Friendly Avenue) Guilford County. Conveyance of an approximate 0.100-acre area comprised of one (1) C-class residue, having a value of \$2,500.00 to Simann Brothers Holdings, LLC for the highest offer amount of \$2,250.00; no additional fees required. This residue was acquired for \$3,404.00 in 2000.

**PROJECTS LIST
NORTH CAROLINA BOARD OF TRANSPORTATION
RALEIGH, NORTH CAROLINA**

May 3-4, 2023

Delegated Authority Secretary Boyette

- (Item C) Award of Highway Construction Contracts April 2023 Letting
- (Item D) Award of Contracts to Private Firms for Engineering Services
- (Item E) Funds for Secondary Road Improvement Projects – Highway Fund and Highway Trust Fund
- (Item H) Funds for Division-wide Small Construction, Statewide Contingency, Public Access, and Economic Development
- (Item L) Funds for Specific Spot Safety Improvement Projects

Action..... Chairman Fox

- (Item G) Additions, Abandonments, and Road Name Changes to State Secondary Road System
- (Item I) Public Transportation Program
 - (Item I-1) Public Transportation
 - (Item I-2) Rail Program
 - (Item I-3) Bicycle and Pedestrian
 - (Item I-4) Aviation
- (Item K) North Carolina Highway Trust Funds
- (Item M) Funds for Specific Federal-Aid Projects
- (Item N) Revisions to the 2020-2029 STIP
- (Item O) Municipal and Special Agreements
- (Item P) Municipal Street System Changes
- (Item R) Right of Way Resolutions and Ordinances
- (Item S) Maintenance Allocations
- (Item T) Submission of Comprehensive Transportation Plans for Mutual Adoption by the Board of Transportation
- (Item V) **(No Item)**

HIGHWAY LETTING
 NORTH CAROLINA DEPARTMENT OF TRANSPORTATION
 DIVISION OF HIGHWAYS
 RALEIGH N.C.
 APRIL 18, 2023
 DIVISION 5

C204380
 44398.3.1
 STATE FUNDED
 WAKE
 U-5826

PROPOSAL LENGTH 1.207 MILES

TYPE OF WORK GRADING, DRAINAGE, PAVING, SIGNALS, AND STRUCTURE.

LOCATION SR-2000 (FALLS OF NEUSE RD) FROM I-540 TO SR-2006 (DURANT RD).

EST CONST PROGRESS.... FY-2024...54% OF BID
 FY-2025...42% OF BID
 FY-2026...04% OF BID

RPN 001 2 BIDDER(S)

DBE GOAL 5.00 %

ESTIMATE 15,211,292.70

DATE AVAILABLE JUL 10 2023

INTER COMPLETION SEP 15 2025 COMPLETE ALL WORK EXCEPT PLANTING, REFORESTATION OR
 PERMANENT VEGETATION ESTABLISHMENT

FINAL COMPLETION MAR 14 2026

	\$ TOTALS	% DIFF
FSC II LLC DBA FRED SMITH COMPANY RALEIGH, NC	19,385,000.00	+27.4
CAROLINA SUNROCK LLC RALEIGH, NC	20,768,245.68	+36.5

AWARDED

HIGHWAY LETTING
 NORTH CAROLINA DEPARTMENT OF TRANSPORTATION
 DIVISION OF HIGHWAYS
 RALEIGH N.C.
 APRIL 18, 2023
 DIVISION 6

C204795
 67073.3.1
 STATE FUNDED
 COLUMBUS
 BR-0073

PROPOSAL LENGTH 3.422 MILES

TYPE OF WORK GRADING, DRAINAGE, PAVING, AND STRUCTURE.

LOCATION BRIDGE #230005 OVER GAPWAY SWAMP ON US-76.

EST CONST PROGRESS.... FY-2023...09% OF BID
 FY-2024...89% OF BID
 FY-2025...02% OF BID

RPN 002 7 BIDDER(S)

DBE GOAL 3.00 %

ESTIMATE 4,431,017.46

DATE AVAILABLE MAY 31 2023

INTER COMPLETION JUL 15 2024 COMPLETE ALL WORK EXCEPT PLANTING, REFORESTATION OR
 PERMENENT VEGETATION ESTABLISHMENT

FINAL COMPLETION JAN 11 2025

	\$ TOTALS	% DIFF
ES WAGNER COMPANY LLC CHARLOTTE, NC	3,878,443.36	-12.5
SMITH-ROWE, LLC MOUNT AIRY, NC	3,969,743.11	-10.4
S T WOOTEN CORPORATION WILSON, NC	4,247,011.26	-4.2
DANE CONSTRUCTION INC MOORESVILLE, NC	4,257,222.84	-3.9
SANFORD CONTRACTORS INC LEMON SPRINGS, NC	4,259,700.00	-3.9
T A LOVING COMPANY GOLDSBORO, NC	5,091,912.00	+14.9
DELLINGER INC MONROE, NC	5,848,172.49	+32.0

AWARDED

HIGHWAY LETTING
 NORTH CAROLINA DEPARTMENT OF TRANSPORTATION
 DIVISION OF HIGHWAYS
 RALEIGH N.C.
 APRIL 18, 2023
 DIVISION 7

C204813
 BP7.R006.3
 STATE FUNDED
 GUILFORD
 BP7-R006

PROPOSAL LENGTH 0.241 MILES

TYPE OF WORK GRADING, DRAINAGE, PAVING, SIGNALS, AND STRUCTURES.

LOCATION BRIDGE #400225 OVER US-29/70 ON SR-1115 (REHOBETH CHURCH RD) IN GREENSBORO.

EST CONST PROGRESS.... FY-2023...04% OF BID
 FY-2024...55% OF BID
 FY-2025...35% OF BID
 FY-2026...06% OF BID

RPN 003 7 BIDDER(S)

DBE GOAL 2.00 %

ESTIMATE 7,927,262.86

DATE AVAILABLE MAY 31 2023

INTER COMPLETION OCT 15 2025 COMPLETE ALL WORK EXCEPT PLANTING, REFORESTATION OR
 PERMANENT VEGETATION ESTABLISHMENT

FINAL COMPLETION APR 13 2026

	\$ TOTALS	% DIFF
ZACHRY CONSTRUCTION CORPORATION SAN ANTONIO, TX	8,420,829.53	+6.2
SMITH-ROWE, LLC MOUNT AIRY, NC	8,797,556.28	+11.0
DANE CONSTRUCTION INC MOORESVILLE, NC	9,077,018.58	+14.5
W C ENGLISH INCORPORATED LYNCHBURG, VA	9,142,692.22	+15.3
CATON CONSTRUCTION GROUP INC CHARLOTTESVILLE, VA	9,661,443.24	+21.9
BRANCH CIVIL INC ROANOKE, VA	9,685,000.00	+22.2
VECELLIO & GROGAN INC BECKLEY, WV	10,518,351.09	+32.7

AWARDED

HIGHWAY LETTING
 NORTH CAROLINA DEPARTMENT OF TRANSPORTATION
 DIVISION OF HIGHWAYS
 RALEIGH N.C.
 APRIL 18, 2023
 DIVISION 7

C204736
 45908.3.1
 0040115
 GUILFORD
 I-5955

PROPOSAL LENGTH 4.735 MILES

TYPE OF WORK PAVEMENT REHABILITATION.

LOCATION I-40 FROM BUFFALO CREEK BRIDGE EAST OF US-220 TO EAST OF SR-3037/SR-4240 (GATE CITY BLVD) IN GREENSBORO.

EST CONST PROGRESS.... FY-2023...11% OF BID
 FY-2024...83% OF BID
 FY-2025...06% OF BID

RPN 004 3 BIDDER(S)

DBE GOAL 5.00 %

ESTIMATE 11,725,051.50

DATE AVAILABLE MAY 31 2023

FINAL COMPLETION SEP 15 2024

	\$ TOTALS	% DIFF
VECELLIO & GROGAN INC DBA SHARPE BROTHERS BECKLEY, WV	11,499,384.23	-1.9
APAC ATLANTIC INC THOMPSON ARTHUR DIVISION GREENSBORO, NC	12,493,000.00	+6.5
BLYTHE CONSTRUCTION INC CHARLOTTE, NC	14,243,632.30	+21.5

AWARDED

HIGHWAY LETTING
 NORTH CAROLINA DEPARTMENT OF TRANSPORTATION
 DIVISION OF HIGHWAYS
 RALEIGH N.C.
 APRIL 18, 2023
 DIVISION 9

C204871
 2023CPT.09.01.10291, 2023CPT.09.02.20291
 STATE FUNDED
 DAVIDSON

PROPOSAL LENGTH 22.812 MILES

TYPE OF WORK MILLING, RESURFACING, AND SHOULDER RECONSTRUCTION.

LOCATION 2 SECTIONS OF US-64 AND 5 SECTIONS OF SECONDARY ROADS.

EST CONST PROGRESS.... FY-2023...09% OF BID
 FY-2024...75% OF BID
 FY-2025...16% OF BID

RPN 006 2 BIDDER(S)

DBE GOAL 6.00 %

ESTIMATE 6,439,337.75

DATE AVAILABLE MAY 31 2023

INTER COMPLETION AUG 25 2023 COMPLETE ALL WORK REQUIRED FOR MAP #3

FINAL COMPLETION NOV 15 2024

	\$ TOTALS	% DIFF
J T RUSSELL & SONS INC ALBEMARLE, NC	6,185,164.61	-3.9
BLYTHE CONSTRUCTION INC CHARLOTTE, NC	7,238,115.57	+12.4

AWARDED

HIGHWAY LETTING
 NORTH CAROLINA DEPARTMENT OF TRANSPORTATION
 DIVISION OF HIGHWAYS
 RALEIGH N.C.
 APRIL 18, 2023
 DIVISION 13

PAGE: 8 of 8
 ITEM C

C204726
 46409.3.3
 0040103
 BUNCOMBE
 I-5889B

PROPOSAL LENGTH 5.110 MILES

TYPE OF WORK PAVEMENT REHABILITATION AND BRIDGE PRESERVATION.

LOCATION I-40 FROM MILEMARKER 45.25 TO MILEMARKER 50.

EST CONST PROGRESS.... FY-2023...06% OF BID
 FY-2024...59% OF BID
 FY-2025...31% OF BID
 FY-2026...04% OF BID

RPN 008 3 BIDDER(S)

DBE GOAL 6.00 %

ESTIMATE 22,126,605.00

DATE AVAILABLE JUN 05 2023

INTER COMPLETION OCT 01 2025 COMPLETE ALL WORK EXCEPT PLANTING, REFORESTATION OR
 PERMANENT VEGETATION ESTABLISHMENT

FINAL COMPLETION MAR 30 2026

	\$ TOTALS	% DIFF
APAC ATLANTIC INC DBA HARRISON CONSTRUCTION COMPANY ASHEVILLE, NC	27,988,062.25	+26.5
MOUNTAIN CREEK CONTRACTORS INC MT PLEASANT, SC	29,157,086.56	+31.8
CROWDER CONSTRUCTION COMPANY CHARLOTTE, NC	33,550,660.06	+51.6

ESTIMATE TOTAL 104,547,183.52

LETTING TOTAL 115,310,863.01 + 10.3

AWARDED

NCDOT MAY 2023
Board of Transportation Agenda

According to Executive Order No. 2 and G. S. 143B-350 (g) the Board is requested to concur with staff recommendations and delegate authority to the Secretary to award contracts to private firms for engineering services.

Professional Services Management

Chief Operating Officer

Chief Engineer - Divisions 1-7

The following is a supplemental contract to a previous contract approved by the Board with the same engineering firm. This supplemental contract was necessary due to approved additional work that was unknown at the inception and is required of the firm to complete the project. Our staff has completed the actions in accordance with the policies and procedures adopted by the Board on May 7, 2009. This is for information only.

DIVISIONS 1-7	
Description of work:	Eastern Divisions (1-7) 2022 Planning and Design Engineering Services Consultant (PDSC) and General Engineering Services Consultant (GESC)
Firm:	Parrish and Partners of North Carolina PLLC, Columbia, SC
Original Engineering Fee:	\$500,000.00
Supplemental Fee:	\$500,000.00
SPSF Utilization:	100%

Chief Engineer - Divisions 8-14

The following are supplemental contracts to previous contracts approved by the Board with the same engineering firms. These supplemental contracts were necessary due to approved additional work that was unknown at the inception and is required of the firms to complete the project. Our staff has completed the actions in accordance with the policies and procedures adopted by the Board on May 7, 2009. This is for information only.

DIVISIONS 8-14	
Description of work:	2021 Western Divisions' (8-14) Planning and Design Engineering Services Consultant (PDSC) and General Engineering Services Consultant (GESC) LSC
Firm:	Gannett Fleming Inc, Philadelphia, PA
Original Engineering Fee:	\$4,000,000.00
Previous Supplemental Fee:	\$3,000,000.00
Supplemental Fee:	\$200,000.00

SPSF Utilization:	Carolina Transportation Engineers & Associates PC
	4% / \$8,000.00
DBE/MBE/SPSF Utilization:	Hearns Real Estate Solutions LLC
	2.5% / \$5,000.00
SPSF Utilization:	Mattern & Craig Inc
	2% / \$4,000.00
SPSF Utilization:	MI Engineering PLLC
	2% / \$4,000.00
SPSF Utilization:	Patriot Transportation Engineering PLLC
	3.5% / \$7,000.00
DBE/WBE/SPSF Utilization:	Richard Grubb And Associates Inc
	1% / \$2,000.00
DBE/WBE/SPSF Utilization:	Three Oaks Engineering Inc
	7.5% / \$15,000.00
Description of work:	2021 Western Divisions' (8-14) Planning and Design Engineering Services Consultant (PDSC) and General Engineering Services Consultant (GESC) LSC
Firm:	Volkert Inc, Birmingham, AL
Original Engineering Fee:	\$3,000,000.00
Supplemental Fee:	\$1,000,000.00
DBE/MBE/SPSF Utilization:	Davenport
	5% / \$50,000.00
DBE/WBE/SPSF Utilization:	Three Oaks Engineering Inc
	4% / \$40,000.00
DBE/WBE/SPSF Utilization:	Westcott Small & Associates PLLC
	2% / \$20,000.00
Description of work:	2021 Western Divisions' (8-14) Planning and Design Engineering Services Consultant (PDSC) and General Engineering Services Consultant (GESC) LSC
Firm:	Kimley Horn & Associates Inc, Atlanta, GA
Original Engineering Fee:	\$4,000,000.00
Previous Supplemental Fee:	\$500,000.00
Supplemental Fee:	\$500,000.00
SPSF Utilization:	Carolina Land Acquisitions Inc
	3% / \$15,000.00
DBE/WBE/SPSF Utilization:	Dovetail Cultural Resource Group
	2% / \$10,000.00
DBE/WBE Utilization:	New South Associates Inc
	2% / \$10,000.00

SPSF Utilization:	Patriot Transportation Engineering PLLC
	5% / \$25,000.00
SPSF Utilization:	Spanish Speaking LLC
	1% / \$5,000.00
DBE/WBE/SPSF Utilization:	Three Oaks Engineering Inc
	1% / \$5,000.00
Description of work:	2021 Western Divisions' (8-14) Planning and Design Engineering Services Consultant (PDSC) and General Engineering Services Consultant (GESC) LSC
Firm:	MS Consultants Inc, Columbus, OH
Original Engineering Fee:	\$3,000,000.00
Previous Supplemental Fee:	\$600,000.00
Supplemental Fee:	\$100,000.00
SPSF Utilization:	MI Engineering PLLC
	8% / \$8,000.00
DBE/WBE/SPSF Utilization:	Three Oaks Engineering Inc
	5.5% / \$5,500.00
SPSF Utilization:	Falcon Engineering Inc
	3% / \$3,000.00

Chief Engineer - Division 10

The following is a supplemental contract to a previous contract approved by the Board with the same engineering firm. This supplemental contract was necessary due to approved additional work that was unknown at the inception and is required of the firm to complete the project. Our staff has completed the actions in accordance with the policies and procedures adopted by the Board on May 7, 2009. This is for information only.

DIVISION 10	
Project:	43609.3.2 (I-5507) Mecklenburg County; 34331.3.25 (R-0211EC) Mecklenburg County; 39078.3.8 (U-4714AB) Mecklenburg County
	I-485 from I-77 South of Charlotte to US 74 (Independence Boulevard). Add one express lane in each direction; I-485 (Charlotte Southern Outer Loop) at SR 3468 (Weddington Road). Construct Interchange; SR 1009 (John Street - Old Monroe Road) at I-485. Improve Interchange.
Scope of Work:	Construction Engineering and Inspection Services
Estimated Construction Cost:	I-5507 - \$285,900,000.00; R-0211EC - \$18,000,000.00; U-4714AB - \$21,200,000.00
Firm:	Transystems Corporation, Chicago, IL
Original Engineering Fee:	\$14,000,000.00
Supplemental Fee:	\$13,539,592.72

Supplemental Work:	Additional Construction Engineering and Inspection Services
SPSF Utilization:	0%

Chief Engineer – Statewide

The following are supplemental contracts to previous contracts approved by the Board with the same engineering firms. These supplemental contracts were necessary due to approved additional work that was unknown at the inception and is required of the firms to complete the project. Our staff has completed the actions in accordance with the policies and procedures adopted by the Board on May 7, 2009. This is for information only.

STATEWIDE	
Description of work:	2020 Statewide On-Call Construction Engineering & Inspection Services LSC
Firm:	S&ME Inc, Atlanta, GA
Original Engineering Fee:	\$10,000,000.00
Previous Supplemental Fee:	\$5,000,000.00
Supplemental Fee:	\$1,000,000.00
SPSF Utilization:	Arete Engineers PLLC
	10% / \$100,000.00
Description of work:	2020 Statewide On-Call Construction Engineering & Inspection Services LSC
Firm:	Transystems Corporation, Chicago, IL
Original Engineering Fee:	\$15,000,000.00
Previous Supplemental Fee:	\$5,000,000.00
Previous Supplemental Fee:	\$5,000,000.00
Previous Supplemental Fee:	\$12,000,000.00
Supplemental Fee:	\$5,000,000.00
SPSF Utilization:	0%

Chief Engineer - Transportation Mobility and Safety

After careful evaluation of the workload and schedules of the work that can be accomplished by our staff, it was determined necessary to employ private firms for Transportation Mobility and Safety services on an as needed basis for various federal-aid and state funded projects to support the Transportation Mobility and Safety Unit. These contracts will expire two (2) years with one (1) possible one (1) year extension after the date of execution or after the contract amount has been depleted, whichever occurs first. Our staff has completed the actions for employing private firms in accordance with the policies and procedures adopted by the Board on May 7, 2009. This is for information only.

STATEWIDE	
Description of Work:	2023 TMSD Limited Services Contract
Firm:	Accelerate Engineering PLLC, Cary, NC
Maximum Engineering Fee:	\$750,000.00
DBE/MBE/SPSF Utilization:	100%

Description of Work:	2023 TMSD Limited Services Contract
Firm:	AECOM Technical Services on North Carolina Inc, Chicago, IL
Maximum Engineering Fee:	\$3,400,000.00
SPSF Utilization:	0%
Description of Work:	2023 TMSD Limited Services Contract
Firm:	Alpha & Omega Group PC, Raleigh, NC
Maximum Engineering Fee:	\$750,000.00
SPSF Utilization:	100%
Description of Work:	2023 TMSD Limited Services Contract
Firm:	Atkins North America Inc, Atlanta, GA
Maximum Engineering Fee:	\$2,100,000.00
SPSF Utilization:	0%
Description of Work:	2023 TMSD Limited Services Contract
Firm:	Exult Engineering PC, Raleigh, NC
Maximum Engineering Fee:	\$4,600,000.00
SPSF Utilization:	100%
Description of Work:	2023 TMSD Limited Services Contract
Firm:	HDR Engineering Inc of the Carolinas, Chicago, IL
Maximum Engineering Fee:	\$1,700,000.00
SPSF Utilization:	0%
Description of Work:	2023 TMSD Limited Services Contract
Firm:	HNTB North Carolina PC, Raleigh, NC
Maximum Engineering Fee:	\$12,200,000.00
SPSF Utilization:	0%
Description of Work:	2023 TMSD Limited Services Contract
Firm:	Ramey Kemp Associates, Raleigh, NC
Maximum Engineering Fee:	\$100,000.00
SPSF Utilization:	0%
Description of Work:	2023 TMSD Limited Services Contract
Firm:	Davenport, Winston Salem, NC
Maximum Engineering Fee:	\$1,000,000.00
DBE/MBE/SPSF Utilization:	100%

Description of Work:	2023 TMSD Limited Services Contract
Firm:	Kimley Horn & Associates Inc, Atlanta, GA
Maximum Engineering Fee:	\$6,400,000.00
SPSF Utilization:	0%
Description of Work:	2023 TMSD Limited Services Contract
Firm:	Kittelson & Associates Inc, Chicago, IL
Maximum Engineering Fee:	\$2,200,000.00
SPSF Utilization:	0%
Description of Work:	2023 TMSD Limited Services Contract
Firm:	Mekuria Engineering Inc, Raleigh, NC
Maximum Engineering Fee:	\$1,000,000.00
DBE/MBE/SPSF Utilization:	100%
Description of Work:	2023 TMSD Limited Services Contract
Firm:	Michael Baker Engineering Inc, Pittsburgh, PA
Maximum Engineering Fee:	\$500,000.00
SPSF Utilization:	0%
Description of Work:	2023 TMSD Limited Services Contract
Firm:	Mott Macdonald I & E LLC, Pittsburgh, PA
Maximum Engineering Fee:	\$2,700,000.00
SPSF Utilization:	0%
Description of Work:	2023 TMSD Limited Services Contract
Firm:	Patriot Transportation Engineering PLLC, Raleigh, NC
Maximum Engineering Fee:	\$3,500,000.00
SPSF Utilization:	100%
Description of Work:	2023 TMSD Limited Services Contract
Firm:	RS&H Architects Engineers Planners Inc, Jacksonville, FL
Maximum Engineering Fee:	\$3,100,000.00
SPSF Utilization:	0%
Description of Work:	2023 TMSD Limited Services Contract
Firm:	RK&K, Raleigh, NC
Maximum Engineering Fee:	\$1,200,000.00
SPSF Utilization:	0%

Description of Work:	2023 TMSD Limited Services Contract
Firm:	Stantec Consulting Services Inc, Chicago, IL
Maximum Engineering Fee:	\$6,000,000.00
SPSF Utilization:	0%
Description of Work:	2023 TMSD Limited Services Contract
Firm:	STV Engineers Inc, Douglasville, PA
Maximum Engineering Fee:	\$200,000.00
SPSF Utilization:	0%
Description of Work:	2023 TMSD Limited Services Contract
Firm:	Summit Design and Engineering Services PLLC, Hillsborough, NC
Maximum Engineering Fee:	\$200,000.00
SPSF Utilization:	0%
Description of Work:	2023 TMSD Limited Services Contract
Firm:	Three Oaks Engineering Inc, Durham, NC
Maximum Engineering Fee:	\$2,000,000.00
DBE/WBE/SPSF Utilization:	100%
Description of Work:	2023 TMSD Limited Services Contract
Firm:	VHB Engineering NC PC, Boston, MA
Maximum Engineering Fee:	\$7,250,000.00
SPSF Utilization:	0%
Description of Work:	2023 TMSD Limited Services Contract
Firm:	Volkert Inc, Birmingham, AL
Maximum Engineering Fee:	\$750,000.00
SPSF Utilization:	0%
Description of Work:	2023 TMSD Limited Services Contract
Firm:	Wetherill Engineering Inc, Raleigh, NC
Maximum Engineering Fee:	\$300,000.00
SPSF Utilization:	100%
Description of Work:	2023 TMSD Limited Services Contract
Firm:	WSP USA Inc, Dallas, TX
Maximum Engineering Fee:	\$1,700,0000.00
SPSF Utilization:	0%

Division of Highways - Design-Build

The Secretary of Transportation awarded a Design-Build contract in January 2023 to upgrade US 70 to interstate standards from the Havelock Bypass to east of SR 1116 (Thurman Road), providing a four-lane divided facility with service roads and three new interchanges in Craven County. In accordance with policies and procedures adopted by the Board, a Design-Build team who was not awarded the project can request payment of a stipend to recover part of the expense of preparation of their proposal. We have received a request for payment of the stipend from the following firms. This is for information only.

Project	(44648.3.4) (R-5777C)
Firm:	Branch Civil, Inc.
Stipend Amount:	\$285,000.00
SPSF Utilization:	0%
Project	(44648.3.4) (R-5777C)
Firm:	Flatiron Constructors, Inc.
Stipend Amount:	\$285,000.00
SPSF Utilization:	0%
Project	(44648.3.4) (R-5777C)
Firm:	S. T. Wooten Corporation
Stipend Amount:	\$285,000.00
SPSF Utilization:	0%

Division of Highways – Roadside Environmental Unit

After careful evaluation of the workload and schedules of the work that can be accomplished by our staff, it was determined necessary to employ private firms for Erosion and Sediment Control Design Services on an as needed basis for various federal-aid and state funded projects to support the Roadside Environmental Unit. These contracts will expire three (3) years with one (1) possible one (1) year extension after the date of execution or after the contract amount has been depleted, whichever occurs first. Our staff has completed the actions for employing private firms in accordance with the policies and procedures adopted by the Board on May 7, 2009. This is for information only.

STATEWIDE	
Description of Work:	2023 Erosion Control & Sediment Control LSC
Firm:	AECOM Technical Services of North Carolina Inc, Chicago, IL
Maximum Engineering Fee:	\$500,000.00
SPSF Utilization:	0%
Description of Work:	2023 Erosion Control & Sediment Control LSC
Firm:	EL Robinson Engineering Co, Charleston, WV
Maximum Engineering Fee:	\$500,000.00
SPSF Utilization:	0%

Description of Work:	2023 Erosion Control & Sediment Control LSC
Firm:	HDR Engineering Inc of the Carolinas, Chicago, IL
Maximum Engineering Fee:	\$500,000.00
SPSF Utilization:	0%
Description of Work:	2023 Erosion Control & Sediment Control LSC
Firm:	Ramey Kemp Associates, Raleigh, NC
Maximum Engineering Fee:	\$500,000.00
SPSF Utilization:	0%
Description of Work:	2023 Erosion Control & Sediment Control LSC
Firm:	KCI Associates of North Carolina PA, Baltimore, MD
Maximum Engineering Fee:	\$500,000.00
SPSF Utilization:	0%
Description of Work:	2023 Erosion Control & Sediment Control LSC
Firm:	Kimley Horn & Associates Inc, Atlanta, GA
Maximum Engineering Fee:	\$500,000.00
SPSF Utilization:	0%
Description of Work:	2023 Erosion Control & Sediment Control LSC
Firm:	LJB Engineering Professional Corporation, Middletown, OH
Maximum Engineering Fee:	\$500,000.00
SPSF Utilization:	0%
Description of Work:	2023 Erosion Control & Sediment Control LSC
Firm:	MI Engineering PLLC, Raleigh, NC
Maximum Engineering Fee:	\$500,000.00
SPSF Utilization:	100%
Description of Work:	2023 Erosion Control & Sediment Control LSC
Firm:	Moffatt & Nichol Incorporated, Los Angeles, CA
Maximum Engineering Fee:	\$500,000.00
SPSF Utilization:	0%
Description of Work:	2023 Erosion Control & Sediment Control LSC
Firm:	MS Consultants Inc, Columbus, OH
Maximum Engineering Fee:	\$500,000.00
SPSF Utilization:	0%

Description of Work:	2023 Erosion Control & Sediment Control LSC
Firm:	NV5 Engineers and Consultants Inc, Chicago, IL
Maximum Engineering Fee:	\$500,000.00
SPSF Utilization:	0%
Description of Work:	2023 Erosion Control & Sediment Control LSC
Firm:	Catlin Engineers and Scientists, Wilmington, NC
Maximum Engineering Fee:	\$500,000.00
SPSF Utilization:	100%
Description of Work:	2023 Erosion Control & Sediment Control LSC
Firm:	RK&K, Raleigh, NC
Maximum Engineering Fee:	\$500,000.00
SPSF Utilization:	0%
Description of Work:	2023 Erosion Control & Sediment Control LSC
Firm:	Summit Design and Engineering Services PLLC, Hillsborough, NC
Maximum Engineering Fee:	\$500,000.00
SPSF Utilization:	0%
Description of Work:	2023 Erosion Control & Sediment Control LSC
Firm:	Sungate Design Group PA, Raleigh, NC
Maximum Engineering Fee:	\$500,000.00
SPSF Utilization:	100%
Description of Work:	2023 Erosion Control & Sediment Control LSC
Firm:	TGS Engineers, Shelby, NC
Maximum Engineering Fee:	\$500,000.00
SPSF Utilization:	0%
Description of Work:	2023 Erosion Control & Sediment Control LSC
Firm:	Three Oaks Engineering Inc, Durham, NC
Maximum Engineering Fee:	\$500,000.00
DBE/WBE/SPSF Utilization:	100%
Description of Work:	2023 Erosion Control & Sediment Control LSC
Firm:	Transystems Corporation, Chicago, IL
Maximum Engineering Fee:	\$500,000.00
SPSF Utilization:	0%

Description of Work:	2023 Erosion Control & Sediment Control LSC
Firm:	VHB Engineering NC PC, Boston, MA
Maximum Engineering Fee:	\$500,000.00
SPSF Utilization:	0%
Description of Work:	2023 Erosion Control & Sediment Control LSC
Firm:	Wetherill Engineering Inc, Raleigh, NC
Maximum Engineering Fee:	\$500,000.00
SPSF Utilization:	100%

Technical Services – Location and Surveys Unit

After careful evaluation of the workload and schedules of the work that can be accomplished by our staff, it was determined necessary to employ private firms for Location & Surveys and General Engineering Services on an as needed basis for various federal-aid and state funded projects to support the Location and Surveys Unit. These contracts will expire Two (2) years with One (1) optional One (1) year extension after the date of execution or after the contract amount has been depleted, whichever occurs first. Our staff has completed the actions for employing private firms in accordance with the policies and procedures adopted by the Board on May 7, 2009. This is for information only.

STATEWIDE	
Description of Work:	2023 Location & Surveys and General Engineering Services Consultant (GESC)
Firm:	Allied Associates PA, Winston Salem, NC
Maximum Engineering Fee:	\$3,000,000.00
SPSF Utilization:	100%
Description of Work:	2023 Location & Surveys and General Engineering Services Consultant (GESC)
Firm:	CES Group Engineers LLP, Charlotte, NC
Maximum Engineering Fee:	\$1,000,000.00
DBE/WBE/SPSF Utilization:	100%
Description of Work:	2023 Location & Surveys and General Engineering Services Consultant (GESC)
Firm:	Dewberry Engineers Inc, Philadelphia, PA
Maximum Engineering Fee:	\$5,000,000.00
SPSF Utilization:	0%
Description of Work:	2023 Location & Surveys and General Engineering Services Consultant (GESC)
Firm:	DRMP NC Inc, Charlotte, NC
Maximum Engineering Fee:	\$2,000,000.00
SPSF Utilization:	0%

Description of Work:	2023 Location & Surveys and General Engineering Services Consultant (GESC)
Firm:	ESP Associates Inc, Charlotte, NC
Maximum Engineering Fee:	\$8,000,000.00
SPSF Utilization:	0%
Description of Work:	2023 Location & Surveys and General Engineering Services Consultant (GESC)
Firm:	GEL Solutions, Charleston, SC
Maximum Engineering Fee:	\$8,000,000.00
SPSF Utilization:	0%
Description of Work:	2023 Location & Surveys and General Engineering Services Consultant (GESC)
Firm:	JMT, Hunt Valley, MD
Maximum Engineering Fee:	\$5,000,000.00
SPSF Utilization:	0%
Description of Work:	2023 Location & Surveys and General Engineering Services Consultant (GESC)
Firm:	Joyner Keeny PLLC, Rocky Mount, NC
Maximum Engineering Fee:	\$4,000,000.00
SPSF Utilization:	100%
Description of Work:	2023 Location & Surveys and General Engineering Services Consultant (GESC)
Firm:	KCI Associates Of North Carolina PA, Baltimore, MD
Maximum Engineering Fee:	\$1,000,000.00
SPSF Utilization:	0%
Description of Work:	2023 Location & Surveys and General Engineering Services Consultant (GESC)
Firm:	Mattern & Craig Inc, Asheville, NC
Maximum Engineering Fee:	\$1,000,000.00
SPSF Utilization:	100%
Description of Work:	2023 Location & Surveys and General Engineering Services Consultant (GESC)
Firm:	McKim & Creed Inc, Hermitage, PA
Maximum Engineering Fee:	\$5,000,000.00
SPSF Utilization:	0%

Description of Work:	2023 Location & Surveys and General Engineering Services Consultant (GESC)
Firm:	NV5 Engineers and Consultants Inc, Chicago, IL
Maximum Engineering Fee:	\$10,000,000.00
SPSF Utilization:	0%
Description of Work:	2023 Location & Surveys and General Engineering Services Consultant (GESC)
Firm:	Surveying and Mapping LLC, Dallas, TX
Maximum Engineering Fee:	\$1,000,000.00
SPSF Utilization:	0%
Description of Work:	2023 Location & Surveys and General Engineering Services Consultant (GESC)
Firm:	TGS Engineers, Shelby, NC
Maximum Engineering Fee:	\$5,000,000.00
SPSF Utilization:	0%
Description of Work:	2023 Location & Surveys and General Engineering Services Consultant (GESC)
Firm:	Wadelynn Geospatial LLC, Garner, NC
Maximum Engineering Fee:	\$5,000,000.00
SPSF Utilization:	100%
Description of Work:	2023 Location & Surveys and General Engineering Services Consultant (GESC)
Firm:	Wetherill Engineering Inc, Raleigh, NC
Maximum Engineering Fee:	\$3,000,000.00
SPSF Utilization:	100%
Description of Work:	2023 Location & Surveys and General Engineering Services Consultant (GESC)
Firm:	Withersravenel Inc, Cary, NC
Maximum Engineering Fee:	\$5,000,000.00
SPSF Utilization:	0%
Description of Work:	2023 Location & Surveys and General Engineering Services Consultant (GESC)
Firm:	WSP USA Inc, Dallas, TX
Maximum Engineering Fee:	\$3,000,000.00
SPSF Utilization:	0%

Deputy Secretary for Multi-Modal Transportation

Multi-Modal Transportatoin – Rail Division

After careful evaluation of the workload and schedules of the work that can be accomplished by our staff, it was determined necessary to employ private firms for Grade Separation and Roadway Design General Oversight on an as needed basis for various federal-aid and state funded projects to support the Rail Division. These contracts will expire three (3) years with one (1) possible one (1) year extension after the date of execution or after the contract amount has been depleted, whichever occurs first. Our staff has completed the actions for employing private firms in accordance with the policies and procedures adopted by the Board on May 7, 2009. This is for information only.

STATEWIDE	
Description of Work:	2023 Rail Division R2R (S-Line) Grade Separation-Roadway Design General Oversight Contract
Firm:	RK&K, Raleigh, NC
Maximum Engineering Fee:	\$1,000,000.00
SPSF Utilization:	American Engineering Associates Southeast PA
	2% / \$20,000.00
SPSF Utilization:	MI Engineering PLLC
	3% / \$30,000.00
Description of Work:	2023 Rail Division R2R (S-Line) Grade Separation-Roadway Design General Oversight Contract
Firm:	TGS Engineers, Shelby, NC
Maximum Engineering Fee:	\$1,000,000.00
SPSF Utilization:	Catlin Engineers and Scientists
	5% / \$50,000.00
SPSF Utilization:	Exult Engineering PC
	5% / \$50,000.00
SPSF Utilization:	Thigpen Engineering & Consulting, PLLC
	5% / \$50,000.00

Turnpike Authority

Turnpike Authority

The following is a supplemental contract to a previous contract approved by the Board with the same engineering firm. This supplemental contract was necessary due to approved additional work that was unknown at the inception and is required of the firm to complete the project. Our staff has completed the actions in accordance with the policies and procedures adopted by the Board on May 7, 2009. This is for information only.

STATEWIDE	
Description of work:	2020 Traffic and Revenue Consulting Services
Firm:	CDM Smith Inc, Atlanta, GA
Original Engineering Fee:	\$2,000,000.00
Supplemental Fee:	\$1,000,000.00
SPSF Utilization:	The Traffic Group Inc
	5% / \$50,000.00

Turnpike Authority

After careful evaluation of the workload and schedules of the work that can be accomplished by our staff, it was determined necessary to employ a private firms for Financial Advisory Services on an as needed basis for various federal-aid and state funded projects to support the Turnpike Authority. This contract will expire Three (3) years with Two (2) possible One (1) year extensions after the date of execution or after the contract amount has been depleted, whichever occurs first. Our staff has completed the actions for employing private firms in accordance with the policies and procedures adopted by the Board on May 7, 2009. This is for information only.

STATEWIDE	
Description of Work:	2023 Financial Advisory Services LSC
Firm:	PFM Financial Advisors LLC, Philadelphia, PA
Maximum Engineering Fee:	\$1,000,000.00
SPSF Utilization:	0%

END of ITEM D.

**NCDOT MAY 2023 BOARD OF TRANSPORTATION AGENDA
Secondary Road Improvement Projects (Highway and Trust Funds)**

According to G.S. 143B-350(g), the Board is requested to concur with staff recommendations and delegate authority to the Secretary to approve funds for Secondary Road Improvement projects

Projects to Establish funds:

Division & County	Secondary Road Number & Name	Project Description	Amount
Division 6 Cumberland Co.	SR 1968 McCall Drive	Grade, drain, base and pave. Establish funds for design and preconstruction. WBS 6C.026084	\$100,697.69
Division 6 Robeson Co.	SR 2461 Dogwood Church Road	Grade, drain, base and pave. Establish funds. WBS 6C.078121	\$600,000.00
Division 10 Cabarrus Co.	SR 2896 Sybbie Street	Grade, drain, base and pave. Establish funds. WBS 10C.013069	\$166,512.16
Division 10 Cabarrus Co.	SR 2464 / SR 2463 Market Circle	Grade, drain, base and pave. Establish funds. WBS 10C.013070	\$200,000.00
Division 12 Gaston Co.	SR 3140 Oakley Drive	Grade, drain, base and pave. Establish funds. WBS 12C.036108	\$125,000.00

Projects to Reopen and establish funds:

Division & County	Secondary Road Number & Name	Project Description	Amount
Division 12 Gaston Co.	SR 1932 Morningside Drive	Grade, drain, base and pave. Reopen and establish funds. WBS 12C.036106	\$125,000.00

Projects to Decrease funds:

Division & County	Secondary Road Number & Name	Project Description	Amount
Division 1 Pasquotank Co.	SR 1364 Sawyers Road	Grade, drain, base and pave. Decrease funds. WBS 1C.070044	(\$150,000.00)

**NCDOT MAY 2023 BOARD OF TRANSPORTATION AGENDA
Secondary Road Improvement Projects (Highway and Trust Funds)**

Projects to Increase funds:

Division & County	Secondary Road Number & Name	Project Description	Amount
Division 1 Martin Co.	SR 1307 Warren Road	Grade, drain, base and pave. Increase funds. WBS 1C.058051	\$150,000.00
Division 3 Brunswick Co.	SR 1967 Seventh Street SE	Grade, drain, base and pave. Increase funds. WBS 3C.010106	\$596,712.53
Division 6 Columbus Co.	SR 1913 Pameter Road	Grade, drain, base and pave. Increase funds. WBS 6C.024123	\$200,000.00
Division 7 Guilford Co.	SR 2390 Mabe Marshall Road	Grade, drain, base and pave. Increase funds. WBS 7C.041266	\$497,559.05
Division 10 Cabarrus Co.	SR 1618 Pleasant Grove Church Road	Grade, drain, base and pave. Increase funds. WBS 10C.013067	\$62,059.27
Division 11 Watauga Co.	SR 1137 Justus Road	Grade, drain, base and pave. Increase funds. WBS 11C.095108	\$267,142.86
Division 12 Iredell Co.	SR 1810 Mitch Road	Grade, drain, base and pave. Increase funds. WBS 12C.049117	\$58,571.43
Division 14 Haywood Co.	SR 1380 Turkey Creek Road	Grade, drain, base and pave. Increase funds. WBS 14C.044182	\$54,793.00
Division 14 Haywood Co.	SR 1160 Oxner Cover Road	Grade, drain, base and pave. Increase funds. WBS 14C.044184	\$30,000.00
Division 14 Macon Co.	SR 1139 Sanders Road	Grade, drain, base and pave. Increase funds. WBS 14C.056132	\$100,000.00
Division 14 Macon Co.	SR 1737 Mountain Breeze Road	Grade, drain, base and pave. Increase funds. WBS 14C.056133	\$15,312.65

**NCDOT MAY 2023 BOARD OF TRANSPORTATION AGENDA
Secondary Road Improvement Projects (Highway and Trust Funds)**

Item E Summary:

5	Projects to Establish Funds	\$1,192,209.85
1	Projects to Reopen and Fund	\$125,000.00
11	Projects to Increase Funds	\$2,032,150.79
0	Projects to Increase and Close	\$0.00
1	Projects to Decrease Funds	(\$150,000.00)
0	Projects to Decrease and Close	\$0.00

NCDOT MAY 2023 BOARD OF TRANSPORTATION AGENDA
Funds Request
Division-wide Small Construction, Statewide Contingency,
Public Access, Economic Development, High Impact/Low Cost

According to Executive Order No. 2 and G.S. 143B-350(g), the Board is requested to concur with staff recommendation and delegate authority to the Secretary to approve funds for specific Division-wide Small Construction / Statewide Contingency projects.

Division & County	Project Description	Fund Type	Amount
Division 3 Pender	WBS 50837 Preliminary engineering and design for a roundabout at the intersection of NC 210, SR 1574 (Dallie Futch Road), and SR 1002 (Island Creek Road). Establish funds	High Impact/ Low Costs <hr/> TOTAL	\$245,000.00 <hr/> \$245,000.00
Division 3 Onslow	WBS 45333.3.21 Construction for TIP Project W-5203U: Install dual left turn lanes on NC 53 and SR 1336 (Henderson Drive) in Jacksonville. These funds are needed to align project funding with the latest estimate. Increase funds	Contingency <hr/> TOTAL	\$500,000.00 <hr/> \$500,000.00
Division 3 New Hanover	WBS 48858 Install traffic signal at SR 1576 (River Road) and SR 2566 (Halyburton Memorial Parkway) Increase funds	High Impact/ Low Costs <hr/> TOTAL	\$102,000.00 <hr/> \$102,000.00
Division 5 Granville	WBS 50792 Install roundabout at US 158 Business (Williamsboro Street) and Gilliam Street / New College Street in Oxford. Establish funds	High Impact/ Low Costs <hr/> TOTAL	\$154,228.89 <hr/> \$154,228.89
Division 5 Wake	WBS 50793 Install traffic signals at SR 1010 (Ten Ten Road) and SR 1377 (Blaney Farm Road); and at SR 1010 (Ten Ten Road) and SR 1404 (Johnson Pond Road). Establish funds	High Impact/ Low Costs <hr/> TOTAL	\$142,757.59 <hr/> \$142,757.59

NCDOT MAY 2023 BOARD OF TRANSPORTATION AGENDA
Funds Request
Division-wide Small Construction, Statewide Contingency,
Public Access, Economic Development, High Impact/Low Cost

Division & County	Project Description	Fund Type	Amount
Division 5 Warren	WBS 49916 Radius improvements at US 401 and US 158 Business in Warrenton. Increase funds	<u>Contingency</u> TOTAL	<u>\$50,000.00</u> \$50,000.00
Division 6 Robeson	WBS 44852.3.26 Construction for TIP Project W-5706Y: Curve improvements along NC 710 at the curve northwest of SR 1345 (Island Grove Road) near Philadelphus. Increase funds	<u>High Impact/ Low Costs</u> TOTAL	<u>\$106,550.00</u> \$106,550.00
Division 7 Guilford	WBS 50806 Install left turn lane on SR 2347 (Lake Brandt Road) at SR 2324 (Plainfield Road). Establish funds	<u>High Impact/ Low Costs</u> TOTAL	<u>\$500,000.00</u> \$500,000.00
Division 8 Richmond	WBS 50799 Widen and strengthen the roadway along sections of SR 1471 (Patterson Road) and SR 1465 (Sycamore Lane). Establish funds	<u>High Impact/ Low Costs</u> TOTAL	<u>\$395,000.00</u> \$395,000.00
Division 8 Richmond	WBS 50833 Upgrade signals at US 220 and Greene Street in Rockingham. Establish funds	<u>High Impact/ Low Costs</u> TOTAL	<u>\$10,000.00</u> \$10,000.00
Division 8 Moore	WBS 50800 Install improvements at NC 2 (Midland Road) and Midland Drive in Pinehurst. Improvements align with the NC 2 (Midland Road) Corridor Study and include closing the Midland Drive median, and adding a left turn lane and a U-turn bulb out on NC 2. Establish funds	<u>High Impact/ Low Costs</u> TOTAL	<u>\$200,000.00</u> \$200,000.00

NCDOT MAY 2023 BOARD OF TRANSPORTATION AGENDA
Funds Request
Division-wide Small Construction, Statewide Contingency,
Public Access, Economic Development, High Impact/Low Cost

Division & County	Project Description	Fund Type	Amount
Division 8 Moore	WBS 50834 Install right turn lane on NC 24 / NC 27 and SR 1477 (Plank Road). Establish funds	High Impact/ Low Costs <u>TOTAL</u>	<u>\$200,000.00</u> \$200,000.00
Division 8 Moore	WBS 50798 Intersection restriping to improve intersection safety at US 15 / US 501 and NC 24 / NC 27 in Carthage. Establish funds	High Impact/ Low Costs <u>TOTAL</u>	<u>\$50,000.00</u> \$50,000.00
Division 8 Moore	WBS 48719.3.1 Construction for Spot Mobility Project SM-5708D: Install intersection improvements at SR 1208 (Page Road) and US 15 / US 501 Increase funds	Small Construction <u>TOTAL</u>	<u>\$125,000.00</u> \$125,000.00
Division 8 Scotland	WBS 50797 Install all way stop at SR 1319 (Old Wired Road) and SR 1001 (Marston Road). Establish funds	High Impact/ Low Costs <u>TOTAL</u>	<u>\$15,000.00</u> \$15,000.00
Division 9 Davidson	WBS 50838 Install roundabout at SR 2205 (Old US 64) and the I-85 Southbound Ramp. Establish funds	High Impact/ Low Costs <u>TOTAL</u>	<u>\$1,100,000.00</u> \$1,100,000.00
Division 10 Anson	WBS 50842 Install intersection improvements at US 74 and NC 218 in Polkton. Establish funds	High Impact/ Low Costs <u>TOTAL</u>	<u>\$150,000.00</u> \$150,000.00

NCDOT MAY 2023 BOARD OF TRANSPORTATION AGENDA
Funds Request
Division-wide Small Construction, Statewide Contingency,
Public Access, Economic Development, High Impact/Low Cost

Division & County	Project Description	Fund Type	Amount
Division 10 Mecklenburg	WBS 50832 Signing and other associated costs for naming a portion of I-485 at the Weddington Road Interchange after Ned Curran. Establish funds	Contingency <u>TOTAL</u>	\$2,000.00 <u>\$2,000.00</u>
Division 10 Stanly	WBS 50778 Reconfigure the intersection at NC 740 and SR 1653 (Blackhawk Lane) / SR 1600 (Wright Road). Establish funds	High Impact/ Low Costs <u>TOTAL</u>	\$50,000.00 <u>\$50,000.00</u>
Division 12 Iredell	WBS 48271.1.1 Preliminary engineering for Spot Mobility Project SM-5712C: Revise signals and install turn lane at NC 3 (Coddle Creek Highway) and SR 1142 (Johnson Diary Road). Increase funds	High Impact/ Low Costs <u>TOTAL</u>	\$200,000.00 <u>\$200,000.00</u>
Division 12 Iredell	WBS 48271.2.1 Right of way for Spot Mobility Project SM-5712C: Revise signals and install turn lane at NC 3 (Coddle Creek Highway) and SR 1142 (Johnson Diary Road). Increase funds	High Impact/ Low Costs <u>TOTAL</u>	\$300,000.00 <u>\$300,000.00</u>
Division 12 Iredell	WBS 48271.3.1 Construction for Spot Mobility Project SM-5712C: Revise signals and install turn lane at NC 3 (Coddle Creek Highway) and SR 1142 (Johnson Diary Road). These funds are needed to align project funding with the latest estimate. Increase funds	High Impact/ Low Costs <u>TOTAL</u>	\$920,905.53 <u>\$920,905.53</u>

NCDOT MAY 2023 BOARD OF TRANSPORTATION AGENDA
Funds Request
Division-wide Small Construction, Statewide Contingency,
Public Access, Economic Development, High Impact/Low Cost

Division & County	Project Description	Fund Type	Amount
Division 12 Gaston	WBS 47834.3.1 Construction for Spot Safety Project SS-4912CM: Install safety improvements at NC 279 (New Hope Road) and SR 2329 (Redbud Road). These funds are needed to align project funding with the latest estimate. Increase funds	Small Construction <u>TOTAL</u>	<u>\$125,000.00</u> \$125,000.00
Division 12 Catawba	WBS 44858.3.11 Construction for TIP Project W-5712K: Upgrade traffic signal and install intersection improvements at SR 1476 (Fairgrove Church Road) and the I-40 Eastbound Ramp. These funds are needed to align project funding with the latest estimate. Establish funds	Small Construction <u>TOTAL</u>	<u>\$132,841.75</u> \$132,841.75
Division 13 Burke	WBS 50831 Upgrade crosswalks and pedestrian facilities at various locations in Morganton near US 70 (Fleming Avenue) and US 64 (Burkemont Avenue). Establish funds	High Impact/ Low Costs <u>TOTAL</u>	<u>\$575,000.00</u> \$575,000.00
Division 13 Rutherford	WBS 50836 Construct access road off SR 2169 (Oakland Road) serving Isothermal Community College in Spindale. Establish funds	Contingency <u>TOTAL</u>	<u>\$500,000.00</u> \$500,000.00
Statewide	WBS 72.1000 Pave driveways from state-maintained roads to the vehicle bay doors of fire departments and rescue facilities [N.C.G.S. 136-18(24)] Increase funds	Public Access <u>TOTAL</u>	<u>\$29,575.61</u> \$29,575.61

NCDOT MAY 2023 BOARD OF TRANSPORTATION AGENDA
Funds Request
Division-wide Small Construction, Statewide Contingency,
Public Access, Economic Development, High Impact/Low Cost

Summary: 27 Projects

High Impact/Low Cost Commitment	\$5,416,442.01
Small Construction Commitment	\$382,841.75
Contingency Commitment	\$1,052,000.00
Economic Development Commitment	\$0.00
Public Access Commitment	\$29,575.61
TOTAL:	<u>\$6,880,859.37</u>

**NCDOT MAY 2023 BOARD OF TRANSPORTATION AGENDA
 APPROVAL OF FUNDS FOR SPECIFIC SPOT SAFETY IMPROVEMENT PROJECTS
 AND FOR SPECIFIC SPOT MOBILITY PROJECTS**

L-1

**ACCORDING TO EXECUTIVE ORDER NO. 2 AND G.S. 143B-350(G) THE BOARD IS
 REQUESTED TO CONCUR WITH STAFF RECOMMENDATIONS AND DELEGATE AUTHORITY
 TO THE SECRETARY TO APPROVE FUNDS FOR SPECIFIC SPOT SAFETY AND SPOT
 MOBILITY IMPROVEMENT PROJECTS**

TOWN / COUNTY DIVISION PROJ.	PROJECT DESCRIPTION	ESTIMATED COST
SHALLOTTE / BRUNSWICK CO. DIV. 3 SM-6103A	WBS 50771 US 17 SOUTHBOUND RAMP AND NC 130. \$258,000.00 IN SPOT MOBILITY FUNDS HAS PREVIOUSLY BEEN APPROVED FOR TRAFFIC SIGNAL INSTALLATION. ADDITIONAL FUNDS ARE NEEDED DUE TO CONSTRUCTION COST INCREASES. INCREASE FUNDS AND TRANSFER \$442,000 FROM SM-6103A (WBS 50771) TO HI IMPACT/LO COST WBS 48862, AND THEN CLOSE SM-6103A (WBS 50771). FILE 03-22-69526-1	\$184,000.00
ONSLOW CO. DIV. 3 SS-6203AE	WBS 50748 SR 1219 (LUTHER BANKS ROAD) AT SR 1230 (HAWES BRANCH ROAD); SR 1107 (DAWSON CABIN ROAD) AT SR 1119 (HIGH HILL ROAD/ERNEST KING ROAD); AND, SR 1434 (BELGRADE SWANSBORO ROAD) AT SR 1442 (STELLA ROAD). \$97,000.00 IN SPOT SAFETY FUNDS HAS PREVIOUSLY BEEN APPROVED FOR ALLWAY STOP INSTALLATIONS. ADDITIONAL FUNDS ARE NEEDED DUE TO RIGHT OF WAY COST INCREASES. FILE 03-22-69791-1	\$21,000.00
GREENSBORO / GUILFORD CO. DIV. 7 SS-6007L	WBS 49289.1.1 SR 4240 (W GATE CITY BOULEVARD) AT FULTON STREET. INITIAL SPOT SAFETY PRELIMINARY ENGINEERING FUNDS ARE NEEDED FOR TRAFFIC SIGNAL INSTALLATION AND PEDESTRIAN ACCOMMODATIONS. FILE 07-19-5961-1	\$5,000.00

MAY 4, 2023

**NCDOT MAY 2023 BOARD OF TRANSPORTATION AGENDA
 APPROVAL OF FUNDS FOR SPECIFIC SPOT SAFETY IMPROVEMENT PROJECTS
 AND FOR SPECIFIC SPOT MOBILITY PROJECTS**

L-2

**ACCORDING TO EXECUTIVE ORDER NO. 2 AND G.S. 143B-350(G) THE BOARD IS
 REQUESTED TO CONCUR WITH STAFF RECOMMENDATIONS AND DELEGATE AUTHORITY
 TO THE SECRETARY TO APPROVE FUNDS FOR SPECIFIC SPOT SAFETY AND SPOT
 MOBILITY IMPROVEMENT PROJECTS**

TOWN / COUNTY DIVISION PROJ.	PROJECT DESCRIPTION	ESTIMATED COST
GREENSBORO / GUILFORD CO. DIV. 7 SS-6007L	WBS 49289.2.1 SR 4240 (W GATE CITY BOULEVARD) AT FULTON STREET. \$9,000 IN SPOT SAFETY RIGHT OF WAY AND UTILITIES FUNDS HAS PREVIOUSLY BEEN APPROVED FOR TRAFFIC SIGNAL INSTALLATION AND PEDESTRIAN ACCOMMODATIONS. ADDITIONAL RIGHT OF WAY FUNDS ARE NEEDED DUE TO RIGHT OF WAY COST INCREASES. FILE 07-19-5961-2	\$106,000.00
GREENSBORO / GUILFORD CO. DIV. 7 SS-6007L	WBS 49289.3.1 SR 4240 (W GATE CITY BOULEVARD) AT FULTON STREET. \$81,000 IN SPOT SAFETY CONSTRUCTION FUNDS HAS PREVIOUSLY BEEN APPROVED FOR TRAFFIC SIGNAL INSTALLATION AND PEDESTRIAN ACCOMMODATIONS. ADDITIONAL FUNDS ARE NEEDED DUE TO CONSTRUCTION COST INCREASES. FILE 07-19-5961-3	\$49,000.00
BUNCOMBE CO. DIV. 13 SS-6413A	WBS 50620 NC 63-NEW LEICESTER HWY AT SR 1369/1822-MT. CARMEL ROAD/FALLEN SPRUCE DRIVE. \$84,000 IN SPOT SAFETY FUNDS HAS PREVIOUSLY BEEN APPROVED FOR PEDESTRIAN ACCOMMODATIONS INCLUDING SIGNALS, CURB RAMPS, SIDEWALK, AND CROSSWALK. ADDITIONAL FUNDS ARE NEEDED DUE TO CONSTRUCTION COST INCREASES. FILE 13-22-208-1	\$48,000.00

**NCDOT MAY 2023 BOARD OF TRANSPORTATION AGENDA
 APPROVAL OF FUNDS FOR SPECIFIC SPOT SAFETY IMPROVEMENT PROJECTS
 AND FOR SPECIFIC SPOT MOBILITY PROJECTS**

L-3

**ACCORDING TO EXECUTIVE ORDER NO. 2 AND G.S. 143B-350(G) THE BOARD IS
 REQUESTED TO CONCUR WITH STAFF RECOMMENDATIONS AND DELEGATE AUTHORITY
 TO THE SECRETARY TO APPROVE FUNDS FOR SPECIFIC SPOT SAFETY AND SPOT
 MOBILITY IMPROVEMENT PROJECTS**

TOWN / COUNTY DIVISION PROJ.	PROJECT DESCRIPTION	ESTIMATED COST
STATEWIDE SM-5715B	WBS 47912.1.1 SCHOOL TRAFFIC ANALYSIS - TRAFFIC ANALYSIS FOR NEW, RELOCATED, AND EXPANDING SCHOOLS. \$3,763,653.21 IN SPOT MOBILITY PRELIMINARY ENGINEERING FUNDS HAS PREVIOUSLY BEEN APPROVED FOR SCHOOL TRAFFIC ANALYSES FOR NEW, RELOCATED, AND EXPANDING SCHOOLS. ADDITIONAL FUNDS ARE NEEDED DUE TO INCREASED PRELIMINARY ENGINEERING COSTS. FILE SW-18-002-2	\$400,000.00
ITEM L SUMMARY	7 PROJECTS	\$813,000.00

NCDOT May 3 - 4, 2023 Board of Transportation Agenda

Additions to the State Highway System:

County	Petition Number	Length Added (Miles)	Description and/or Subdivision	Date of Report
Division 4				
Johnston	52731	0.31	Brodie Rose Landing Brodie Rose Landing Way	2/28/23
Johnston	52732	0.19 0.12 0.03 0.10	Langdon Farms Upton Drive Hound Dog Lane N. Rabbit Run Drive S. Rabbit Run Drive	2/17/23
Division 5				
Wake	52733	0.53 0.26 0.18	Mendenhall Mendenhall Drive Abby Rose Court Bella Woods Drive	3/2/23
Division 7				
Guilford	52734	0.15 0.18 0.09	Thatcher Woods Thatcher Woods Drive Bateman Court Alton Drive	3/7/23
Rockingham	52735	0.26 0.05	Cedar Hollow Mustang Run Appaloosa Court	3/3/23
Division 8				
Chatham	52736	0.20 0.10 0.25	Windfall Creek Extend SR 1898, Windfall Creek Drive Swaying Trees Court Gentle Winds Drive	12/8/21
Scotland	52737	0.17	Scotland County Economic Development SoPakCo Access Road	3/22/23
Division 10				
Mecklenburg	52738	0.04 0.59 0.08 0.05 0.32	Enclave at Montreux (Meridians) Montreux Levaux Drive Batteliere Drive Dufaux Drive Grisons Court Bastille Drive	11/3/22
Stanly	52739	0.27	Ellis Spring Ellis Spring Court	2/28/20

NCDOT May 3 - 4, 2023 Board of Transportation Agenda

Abandonments from the State Highway System:

County	Petition Number	Length Abandoned (Miles)	Description and/or Subdivision	Date of Report
Division 4				
Wayne	52740	0.03	Portion of SR 1327, Leslie Road Retain 0.65 miles	2/15/23
Wilson	52741	0.08	Portion of SR 1212, Old Merck Road Retain 0.24 miles	3/7/23
Division 5				
Vance	52742	0.03	Portion of SR 1562, Cardinal Drive Retain 0.52 miles	8/3/22
Vance	52743	0.54	Portion of SR 1330, Bullock Road Retain 0.15 miles	11/9/22
Division 7				
Rockingham	52744	0.07	Portion of SR 2431, Monroeton Golf Course Road Retain 0.75 miles	3/9/23
Division 9				
Rowan	52745	0.11	Portion of SR 2565, Carter Loop Road Retain 1.23 miles	2/2/23

Number of roads petitioned for addition – 23
Number of roads petitioned for abandonment - 6

Corrections to the State Highway System:

County	Requested Action
--------	------------------

none

NCDOT May Board of Transportation Agenda

Public Transportation Program

<u>Division</u>	<u>Project Number</u>	<u>5303</u>	<u>Estimated Project Cost</u>
02	24-08-121	CITY OF GREENVILLE FY24 Metropolitan Planning Organization The City of Greenville operating as the Greenville Urban Area MPO, is requesting funds for transit planning in the MPO area. Application Number: 1000017703	\$60,080.00 Total
			\$48,064.00 Federal
			\$6,008.00 State
			\$6,008.00 Local
02	24-08-125	CITY OF NEW BERN FY24 Metropolitan Planning Organization The City of New Bern, operating as the New Bern Urban Area MPO, is requesting funds for transit planning in the MPO area. Application Number: 1000017561	\$60,080.00 Total
			\$48,064.00 Federal
			\$6,008.00 State
			\$6,008.00 Local
03	24-08-114	CITY OF JACKSONVILLE TRANSIT DEPARTMENT FY24 Metropolitan Planning Organization The City of Jacksonville, operating as the Jacksonville Urban Area MPO, is requesting funds for transit planning in the MPO area. Application Number: 1000017529	\$60,080.00 Total
			\$48,064.00 Federal
			\$6,008.00 State
			\$6,008.00 Local
03	24-08-124	CITY OF WILMINGTON FY24 Metropolitan Planning Organization The City of Wilmington, operating as the Wilmington Urbanized area MPO, is requesting funds for transit planning in the MPO area. Application Number: 1000017480	\$103,906.00 Total
			\$83,124.00 Federal
			\$10,390.00 State
			\$10,392.00 Local
03	24-08-124	WACCAMAW REGIONAL COUNCIL OF GOVERNMENTS FY24 Metropolitan Planning Organization The Waccamaw Regional Council of Governments, operating as the Grand Strand Area Transportation Study (MPO), is requesting funds for transit planning in the MPO area. Application Number: 1000017656	\$24,032.00 Total
			\$19,225.00 Federal
			\$2,403.00 State
			\$2,404.00 Local
04	24-08-110	CITY OF GOLDSBORO FY24 Metropolitan Planning Organization The City of Goldsboro operating as the Goldsboro Urban Area MPO, is requesting funds for transit planning in the MPO area. Application Number: 1000017537	\$60,080.00 Total
			\$48,064.00 Federal
			\$6,008.00 State
			\$6,008.00 Local

04	24-08-115	CITY OF ROCKY MOUNT TAX COLLECTOR FY24 Metropolitan Planning Organization The City of Rocky Mount operating as the Rocky Mount Urban Area MPO, is requesting funds for transit planning in the MPO area. Application Number: 1000017636	
			\$60,078.00 Total
			\$48,062.00 Federal
			\$6,007.00 State
			\$6,009.00 Local
05	24-08-103	CITY OF DURHAM MPO ACCOUNTING SERVICES FY24 Metropolitan Planning Organization The City of Durham operating as the Durham Chapel Hill Carrboro MPO, is requesting funds for transit planning in the MPO area. Application Number: 1000017516	
			\$504,167.00 Total
			\$403,333.00 Federal
			\$50,416.00 State
			\$50,418.00 Local
05	24-08-103	CITY OF RALEIGH FY24 Metropolitan Planning Organization The City of Raleigh operating as the Capital Area MPO, is requesting funds for transit planning in the MPO area. Application Number: 1000017660	
			\$560,865.00 Total
			\$448,692.00 Federal
			\$56,086.00 State
			\$56,087.00 Local
06	24-08-044	CUMBERLAND COUNTY JOINT PLANNING BOARD FY24 Metropolitan Planning Organization The Cumberland County Joint, operating as the Fayetteville Area MPO, is requesting funds for transit planning in the MPO area. Application Number: 1000017133	
			\$146,332.00 Total
			\$117,065.00 Federal
			\$14,633.00 State
			\$14,634.00 Local
07	24-08-105	CITY OF GREENSBORO FY24 Metropolitan Planning Organization The City of Greensboro, operating as the Greensboro MPO, is requesting funds for transit planning in the MPO area. Application Number: 1000017791	
			\$271,741.00 Total
			\$217,392.00 Federal
			\$27,174.00 State
			\$27,175.00 Local
07	24-08-107	CITY OF BURLINGTON FY24 Metropolitan Planning Organization The City of Burlington, operating as the Burlington-Graham Urbanized Area MPO, is requesting funds for transit planning in the MPO area. Application Number: 1000017713	
			\$60,080.00 Total
			\$48,064.00 Federal
			\$6,008.00 State
			\$6,008.00 Local
07	24-08-113	CITY OF HIGH POINT FY24 Metropolitan Planning Organization The City of High Point operating as the High Point MPO, is requesting funds for transit planning in the MPO area. Application Number: 1000017575	
			\$81,334.00 Total
			\$65,067.00 Federal
			\$8,133.00 State
			\$8,134.00 Local

09	24-08-106	CITY OF WINSTON SALEM FY24 Metropolitan Planning Organization The City of Winston-Salem operating as the Winston-Salem MPO, is requesting funds for transit planning in the MPO area. Application Number: 1000017559	
			\$189,246.00 Total
			\$151,396.00 Federal
			\$18,924.00 State
			\$18,926.00 Local
10	24-08-102	CITY OF CHARLOTTE FY24 Metropolitan Planning Organization The City of Charlotte, operating as the Charlotte Regional Transportation Planning Organization, is requesting funds for transit planning in the MPO area. Application Number: 1000017709	
			\$1,363,911.00 Total
			\$1,091,128.00 Federal
			\$136,391.00 State
			\$136,392.00 Local
10	24-08-108	CITY OF CONCORD FINANCE DEPT FY24 Metropolitan Planning Organization The City of Concord, operating as the Cabarrus-Rowan Urbanized Area MPO, is requesting funds for transit planning in the MPO area. Application Number: 1000017743	
			\$106,570.00 Total
			\$85,256.00 Federal
			\$10,657.00 State
			\$10,657.00 Local
12	24-08-109	CITY OF GASTONIA FINANCE DIRECTOR FY24 Metropolitan Planning Organization The City of Gastonia operating as the Gaston-Cleveland-Lincoln MPO, is requesting funds for transit planning in the MPO area. Application Number: 1000017557	
			\$65,918.00 Total
			\$52,734.00 Federal
			\$6,591.00 State
			\$6,593.00 Local
12	24-08-112	WESTERN PIEDMONT COUNCIL OF GOVERNMENTS FY24 Metropolitan Planning Organization Western Piedmont Council of Governments (WPCOG), operating as the Greater Hickory MPO, is requesting funds for transit planning in the MPO area. Application Number: 1000017527	
			\$74,861.00 Total
			\$59,888.00 Federal
			\$7,486.00 State
			\$7,487.00 Local
13	24-08-100	CITY OF ASHEVILLE ATTENTION ACCOUNTING DIVISION FY24 Metropolitan Planning Organization The city of Asheville, operating as the French Broad River MPO; is requesting funding for transit planning in the MPO area Application Number: 1000017731	
			\$151,900.00 Total
			\$121,520.00 Federal
			\$15,190.00 State
			\$15,190.00 Local
<u>Division</u>	<u>Project Number</u>	<u>URBAN STATE MATCH</u>	<u>Estimated Project Cost</u>
06	24-UM-104	CITY OF FAYETTEVILLE FY24 URBAN STATE MATCH CAPITAL Urban state match funds for capital purchase of (2) 40 ft battery electric buses, (2) 35 ft diesel buses for Fayetteville. Application Number: 1000016185	
			\$4,460,000.00 Total
			\$3,785,202.00 Federal <i>Non-billable</i>
			\$317,998.00 State
			\$356,800.00 Local

07	24-UM-105	CITY OF GREENSBORO FY24 URBAN STATE MATCH CAPITAL State match for Urban Capital to purchase replacements for (4) 35ft bus, and (4) 40ft bus for Greensboro Transit Agency (GDOT). Application Number: 1000016531	
			\$4,309,412.00 Total
			\$3,663,000.00 Federal <i>Non-billable</i>
			\$301,658.00 State
			\$344,754.00 Local
07	24-UM-107	CITY OF BURLINGTON FY24 URBAN STATE MATCH CAPITAL State match for Urban Capital to purchase replacements for (2) 30ft Electric bus, (5) 28ft bus, and (3) 23ft bus for Burlington Link Transit. Application Number: 1000017224	
			\$2,425,489.00 Total
			\$1,940,391.00 Federal <i>Non-billable</i>
			\$242,548.00 State
			\$242,550.00 Local
07	24-UM-117	TOWN OF CHAPEL HILL FY24 URBAN STATE MATCH CAPITAL State match for Urban Capital to purchase replacements for (5) 40ft buses for Chapel Hill Transit. Application Number: 1000016389	
			\$5,300,000.00 Total
			\$2,040,000.00 Federal <i>Non-billable</i>
			\$1,060,000.00 State
			\$2,200,000.00 Local
07	24-UM-120	PIEDMONT AUTHORITY FOR REGIONAL TRANSPORTATION FY24 URBAN STATE MATCH CAPITAL State match for Urban Capital to purchase replacements for (13) vans for Piedmont Authority of Regional Transportation (PART). Application Number: 1000016243	
			\$570,000.00 Total
			\$456,000.00 Federal <i>Non-billable</i>
			\$57,000.00 State
			\$57,000.00 Local
<u>Division</u>	<u>Project Number</u>	<u>ADVANCED TECHNOLOGY</u>	<u>Estimated Project Cost</u>
05	24-AT-118	RESEARCH TRIANGLE REGIONAL PUBLIC TRANSPORTATION FY24 Advanced Technology Urban Advanced Technology implementation of Share the Ride NC ride matching software for Go Triangle. Application Number: 1000018012	
			\$54,800.00 Total
			\$0.00 Federal
			\$49,320.00 State
			\$5,480.00 Local
07	24-AT-117	TOWN OF CHAPEL HILL FY24 Advanced Technology Urban Advanced Technology implementation of an AVL Upgrade On-Board Multimedia Infotainment for Chapel Hill Transit System. Application Number: 1000018267	
			\$200,000.00 Total
			\$0.00 Federal
			\$180,000.00 State
			\$20,000.00 Local

<u>Division</u>	<u>Project Number</u>	<u>ConCPT</u>	<u>Estimated Project Cost</u>
07	24-CO-120	PIEDMONT AUTHORITY FOR REGIONAL TRANSPORTATION FY24 ConCPT Coordination - Operating Support for the coordination of trips between three or more transit systems: Piedmont Authority for Regional Transportation, Guilford County, Randolph County Application Number: 1000018293	\$400,000.00 Total
			\$0.00 Federal
			\$200,000.00 State
			\$200,000.00 Local
02	24-CO-054	CARTERET COUNTY FINANCE OFFICER FY24 ConCPT Coordination - Operating Support for the coordination of trips between three or more transit systems: Carteret County, CARTS, Lenoir County, GWTA, JCATS, OUTS, Duplin County, and Greene County (DownEast Express) Application Number: 1000014931	\$200,000.00 Total
			\$0.00 Federal
			\$100,000.00 State
			\$100,000.00 Local
03	24-CO-052	CAPE FEAR PUBLIC TRANSPORTATION AUTHORITY DBA WAVE FY24 ConCPT Coordination - Operating Support for the coordination of trips between three or more transit systems: Cape Fear Public Transportation, Brunswick County, Pender County Application Number: 1000016777	\$600,000.00 Total
			\$0.00 Federal
			\$600,000.00 State
			\$0.00 Local
<u>Division</u>	<u>Project Number</u>	<u>RURAL STATE OPERATING</u>	<u>Estimated Project Cost</u>
01	24-RO-005	ALBEMARLE REGIONAL HEALTH SERVICES FY24 Rural State Operating Grant State Operating funds for multi-county transit system by Albemarle Regional Health Services Application Number: 1000015925	\$600,000.00 Total
			\$0.00 Federal
			\$300,000.00 State
			\$300,000.00 Local
01	24-RO-025	HYDE COUNTY NON-PROFIT PRIVATE TRANSPORTATION CORP FY24 Rural State Operating Grant State Operating funds for multi-county transit system by Hyde County Non-Profit Application Number: 1000016138	\$25,166.00 Total
			\$0.00 Federal
			\$12,583.00 State
			\$12,583.00 Local
04	24-RO-047	GOLDSBORO WAYNE TRANSPORTATION AUTHORITY FY24 Rural State Operating Grant State Operating funds for multi-county transit system by Goldsboro-Wayne Transit System. Application Number: 1000016318	\$130,000.00 Total
			\$0.00 Federal
			\$65,000.00 State
			\$65,000.00 Local
05	24-RO-030	KERR AREA TRANSPORTATION AUTHORITY FY24 Rural State Operating Grant State Operating funds for multi-county transit system by KARTS Transit System. Application Number: 1000016284	\$442,566.00 Total
			\$0.00 Federal
			\$221,283.00 State
			\$221,283.00 Local

11	24-RO-007	APPALCART FY24 Rural State Operating Grant State Operating funds for multi-county transit system by AppalCart Transit System. Application Number: 1000016238	
			\$210,932.00 Total
			\$0.00 Federal
			\$105,466.00 State
			\$105,466.00 Local
11	24-RO-031	YADKIN VALLEY ECONOMIC DEVELOPMENT DISTRICT INC FY24 Rural State Operating Grant State Operating funds for multi-county transit system by Yadkin Valley Economic Dev District (YVEDDI) Transit System. Application Number: 1000016002	
			\$203,922.00 Total
			\$0.00 Federal
			\$101,961.00 State
			\$101,961.00 Local
13	24-RO-080	WESTERN PIEDMONT REGIONAL TRANSIT AUTHORITY FY24 Rural State Operating Grant State Operating funds for multi-county transit systems by Western Piedmont Regional Transit Authority for Greenway Public Transportation. Application Number: 1000016486	
			\$293,396.00 Total
			\$0.00 Federal
			\$146,698.00 State
			\$146,698.00 Local
<u>Division</u>	<u>Project Number</u>	<u>TRANSPORTATION DEMAND MANAGEMENT</u>	<u>Estimated Project Cost</u>
	24-RS-932	LAND-OF-SKY REGIONAL COUNCIL FY24 Rideshare French Broad River MPO and Land of Sky RPO will use these funds to support transportation demand management administration and/or program elements in the planning areas that include the counties of Buncombe, Henderson, Haywood, Madison, and Transylvania. It also includes the metropolitan areas of Greater Asheville and Greater Hendersonville which includes towns of Brevard, Waynesville, Weaverville, Black Mountain, Canton, Marshall, and Mars Hill. Application Number: 1000017892	
			\$115,095.00 Total
			\$0.00 Federal
			\$57,547.00 State
			\$57,548.00 Local
05	24-RS-901B	TRIANGLE J COUNCIL OF GOVERNMENTS FY24 Rideshare TJCOG will use the funds for the Triangle Transportation Demand Management program for marketing services to help commuters find transportation alternatives to the single-occupant vehicle throughout the Triangle. Application Number: 1000017896	
			\$1,203,324.00 Total
			\$0.00 Federal
			\$601,662.00 State
			\$601,662.00 Local

05	24-RS-901A	TRIANGLE J COUNCIL OF GOVERNMENTS FY24 Rideshare TJCOG will use the funds for the Triangle Transportation Demand Management program for marketing services to help commuters find transportation alternatives to the single-occupant vehicle throughout the Triangle. Application Number: 1000018061	
			\$138,702.00 Total
			\$0.00 Federal
			\$138,702.00 State
			\$0.00 Local
07	24-RS-120	PIEDMONT AUTHORITY FOR REGIONAL TRANSPORTATION FY24 Rideshare PART will use these funds to support transportation demand management administration and/or program elements in the greater triad area including Alamance, Davie, Davidson, Forsyth, Guilford, Randolph, Rockingham, Stokes, Surry and Yadkin counties. Application Number: 1000017877	
			\$535,249.00 Total
			\$0.00 Federal
			\$267,624.00 State
			\$267,625.00 Local
10	24-RS-102	CITY OF CHARLOTTE FY24 Rideshare City of Charlotte will use these funds to support transportation demand management administration and/or program elements in the Charlotte area. Application Number: 1000017915	
			\$292,136.00 Total
			\$0.00 Federal
			\$146,068.00 State
			\$146,068.00 Local
10	24-RS-906	SUSTAIN CHARLOTTE INC FY24 Rideshare Sustain Charlotte will use these funds to support transportation demand management administration and/or program elements in the Charlotte area. Application Number: 1000017878	
			\$148,628.00 Total
			\$0.00 Federal
			\$74,314.00 State
			\$74,314.00 Local
10	24-RS-912	CENTRALINA COUNCIL OF GOVERNMENT FY24 Rideshare Centralina Council of Government will use these funds to support transportation demand management administration and/or program elements in the Charlotte area. Application Number: 1000017745	
			\$80,000.00 Total
			\$0.00 Federal
			\$40,000.00 State
			\$40,000.00 Local
<u>Division</u>	<u>Project Number</u>	<u>TRAVELER'S AID</u>	<u>Estimated Project Cost</u>
03	24-TA-055	ONSLOW UNITED TRANSIT SYSTEM INC FY24 Traveler's Aid State match program for relocation assistance for those in need provided by Onslow United Transit System. Application Number: 1000016148	
			\$5,000.00 Total
			\$0.00 Federal
			\$2,500.00 State
			\$2,500.00 Local

06	24-TA-040	HARNETT COUNTY FY24 Traveler's Aid State match program for relocation assistance for those in need provided by Harnett Transit System. Application Number: 1000017068	
			\$5,000.00 Total
			\$0.00 Federal
			\$2,500.00 State
			\$2,500.00 Local
10	24-TA-905	COMMUNITY LINK PROGRAMS OF TRAVELERS AID SOCIETY FY24 Traveler's Aid State match program for relocation assistance for those in need provided by Community Link Programs of Travelers Aid Transit System. Application Number: 1000015789	
			\$39,000.00 Total
			\$0.00 Federal
			\$19,500.00 State
			\$19,500.00 Local
<u>Division</u>	<u>Project Number</u>	<u>FY22 & FY23 5311 CAPITAL</u>	<u>Estimated Project Cost</u>
02	22-CT-007	APPALCART is requesting additional funds due to the increase in vehicle cost. FY22 5311 Agreement Number: 2000049650	
			\$28,000.00 Total
			\$22,400.00 Federal
			\$2,800.00 State
			\$2,800.00 Local
03	22-CT-015	SAMPSON COUNTY is requesting additional funds due to the increase in vehicle cost. FY22 5311 Agreement Number:2000048199	
			\$130,000.00 Total
			\$104,000.00 Federal
			\$26,000.00 State
			\$0 Local
03	22-CT-015	SAMPSON COUNTY is requesting additional funds due to the increase in vehicle cost. FY22 5311 Agreement Number:2000048029	
			\$320,000.00 Total
			\$256,000.00 Federal
			\$0 State
			\$64,000.00 Local
02	23-CT-017	BEAUFORT COUNTY DEVELOPMENT CENTER, INC is requesting additional funds due to the increase in vehicle cost. FY23 5311 Agreement Number: 2000062262	
			\$82,690.00 Total
			\$66,152.00 Federal
			\$0 State
			\$16,538 Local

<u>Division</u>	<u>Project Number</u>	<u>FY24 5311 ADMIN</u>	<u>Estimated Project Cost</u>					
13	24-CT-009	YANCEY COUNTY TRANSPORTATION AUTHORITY FY24 Community Transportation Admin. Administrative costs related to rural community transportation services provided by Yancey County Application Number: 1000017161	<table border="1"> <tr> <td data-bbox="1271 180 1581 218"></td> </tr> <tr> <td data-bbox="1271 218 1581 256">\$130,822.00 Total</td> </tr> <tr> <td data-bbox="1271 256 1581 294">\$104,657.00 Federal</td> </tr> <tr> <td data-bbox="1271 294 1581 331">\$6,541.00 State</td> </tr> <tr> <td data-bbox="1271 331 1581 369">\$19,624.00 Local</td> </tr> </table>		\$130,822.00 Total	\$104,657.00 Federal	\$6,541.00 State	\$19,624.00 Local
\$130,822.00 Total								
\$104,657.00 Federal								
\$6,541.00 State								
\$19,624.00 Local								

Item I-I: Total Projects 52: Total Federal and State Funds
\$9,605,205 (not including federal non-billable amounts)
\$21,489,798 (including federal non-billable amounts)

<u>No of Projects</u>	<u>Program ID</u>	<u>Federal Amount</u>	<u>State Amount</u>	<u>Local Amount</u>	<u>Total Amount</u>
19	P2024_5303_PLANNING	\$3,204,202	\$400,521	\$400,538	\$4,005,261
3	P2024_ADVANCE TECHNOLOGY	\$0	\$229,320	\$25,480	\$254,800
3	ConCPT	\$0	\$900,000	\$300,000	\$1,200,000
7	P2024_RURAL STATE OPER	\$0	\$952,991	\$952,991	\$1,905,982
7	P2024_TDM	\$0	\$1,325,917	\$1,187,217	\$2,513,134
3	P2024_TRAVELERS AID	\$0	\$24,500	\$24,500	\$49,000
3	P2022_5311_CAPITAL	\$382,400	\$28,800	\$64,000	\$475,200
1	P2023_5311_CAPITAL	\$66,152	\$0	\$16,538	\$82,690
1	P2024_5311_ADMIN	\$104,657	\$6,541	\$19,624	\$ 130,822

<u>No of Projects</u>	<u>Program ID</u>	<u>Federal Amount (Non-Billable)</u>	<u>State Amount</u>	<u>Local Amount</u>	<u>Total Amount</u>
5	P2024_ URBAN STATE MATCH	\$11,884,593	\$1,979,204	\$3,201,104	\$17,064,901 (includes federal non-billable)
52	TOTAL	\$15,642,004 (includes federal non-billable)	\$5,847,794	\$6,191,992	\$27,681,790 (includes federal non-billable)

NCDOT May 2023 Board of Transportation Agenda

Rail Program

Town/County Division	Project Description	Estimated Cost
Division 1 Pasquotank, Chowan, Camden County 80000.1.4.150	The Rail Division requests Board approval of Freight Rail & Rail Crossing Safety Improvement (FRRCSI) funds for the Chesapeake & Albemarle Railroad (CA). The project will extend a siding, upgrade turnouts, return a rail siding to service, and provide rail improvements along the CA corridor. CA will be responsible for the construction of the project. The total estimated cost to the Department is \$570,000. FRRCSI ID: F23118	\$570,000
Divisions 1, 2, 4, 5 Beaufort, Greene, Johnston, Martin, Nash, Pitt, Wake, Washington, Wilson County 80000.1.4.122	The Rail Division requests Board approval of additional Freight Rail & Rail Crossing Safety Improvement (FRRCSI) funds for the Carolina Coastal Railway (CLNA). The project will provide bridge modernization, crosstie upgrades, and speed improvements. This supplemental funding is needed due to escalating material costs. CLNA will be responsible for the construction of the project. Department funding was approved for \$1,120,000 on May 8, 2022. With this supplemental funding, the total estimated project cost is \$2,540,000 and the Department will fund up to 50% of the project costs, not to exceed \$1,270,000. FRRCSI ID: F22102	\$150,000
Divisions 2, 4, 5 Beaufort, Warren, Nash Counties 80000.1.4.149	The Rail Division requests Board approval of Freight Rail & Rail Crossing Safety Improvement (FRRCSI) funds for the Carolina Coastal Railway (CLNA). The project will provide improvements along the CLNA corridor. CLNA will be responsible for the construction of the project. The total estimated cost to the Department is \$385,000. FRRCSI ID: F23117	\$385,000
Division 8 Montgomery County 80000.3.4.3	The Rail Division requests Board approval of Freight Rail & Rail Crossing Safety Improvement (FRRCSI) funds for the Aberdeen Carolina & Western Railroad (ACWR). The project will expand an ongoing short line improvement project that is building a rail yard. Additional enhancements will facilitate a full truck-rail transloading operation in Candor. ACWR will be responsible for the construction of the project. The total estimated cost to the Department is \$1,060,000. FRRCSI ID: F23123	\$1,060,000
Division 8 Montgomery County 80000.1.4.152	The Rail Division requests Board approval of Freight Rail & Rail Crossing Safety Improvement (FRRCSI) funds for the Aberdeen Carolina & Western Railroad (ACWR). The project will upgrade culverts on the ACWR rail corridor for improved drainage. ACWR will be responsible for the construction of the project. The total estimated cost to the Department is \$490,000. FRRCSI ID: F23120	\$490,000

NCDOT May 2023 Board of Transportation Agenda

Rail Program

<p>Division 8 Randolph County 80000.3.1.26</p>	<p>The Rail Division requests Board approval of Freight Rail & Rail Crossing Safety Improvement (FRRCSI) funding to assist in the construction improvements to the Sumitomo Forestry America Inc. industrial site. The project will construct rail access to the industry. Sumitomo Forestry America Inc. will be responsible for the construction of the project. The total estimated cost to the Department is \$210,000. FRRCSI ID: F23115</p>	<p>\$210,000</p>
<p>Division 10 Mecklenburg County 80000.3.4.2</p>	<p>The Rail Division requests Board approval of Freight Rail & Rail Crossing Safety Improvement (FRRCSI) funds for the Aberdeen Carolina & Western Railroad (ACWR). The project will expand an ongoing short line improvement project that is building a rail yard. Additional enhancements will facilitate a full truck-rail transloading operation in Mint Hill. ACWR will be responsible for the construction of the project. The total estimated cost to the Department is \$1,250,000. FRRCSI ID: F23122</p>	<p>\$1,250,000</p>
<p>Division 12 Gaston County 80000.1.4.153</p>	<p>The Rail Division requests Board approval of Freight Rail & Rail Crossing Safety Improvement (FRRCSI) funds for the Charlotte Western Railroad (CER). The project will provide improvements along the CER rail corridor. CER will be responsible for the construction of the project. The total estimated cost to the Department is \$185,000. FRRCSI ID: F23121</p>	<p>\$185,000</p>
<p>Division 12 Iredell County 80000.1.4.151</p>	<p>The Rail Division requests Board approval of Freight Rail & Rail Crossing Safety Improvement (FRRCSI) supplemental funding to assist in the construction of improvements to the Alexander Railroad Co. (ARC). The project will upgrade rail and provide improvements along the ARC rail corridor. ARC will be responsible for the construction of the project. The total estimated cost to the Department is \$365,000. FRRCSI ID: F23119</p>	<p>\$365,000</p>
<p>Statewide 80000.2.4.1</p>	<p>The Rail Division requests board approval of additional Freight Rail & Rail Crossing Safety Improvement (FRRCSI) funding for crossing consolidation and safety program management. The additional funding will allow for an on-going annual program and project management of track and safety infrastructure assistance projects. The total estimated cost to the Department is \$650,000.</p>	<p>\$650,000</p>

ITEM I - 2 SUMMARY – 10 PROJECTS - (TOTAL STATE) \$5,315,000

May 4, 2023

**NCDOT May Board of Transportation Agenda
Bicycle and Pedestrian Transportation Program**

Town/County Division	Paved Trails and Sidewalks Feasibility Studies Program	Estimated Cost	
Franklin Macon County Division 14	Town of Franklin Paved Trail Feasibility Study Crawford Branch Greenway and Boardwalk	\$62,825 \$0 \$62,825	Total Federal State

Total Projects 1: Total Federal (\$0) + Total State (\$62,825) = Combined Total (\$62,825)

NCDOT May 2023 Board of Transportation Agenda

Aviation Program

Division Airport County	Project Description	Estimate
Division 4 Mount Olive Municipal Airport Wayne County	New Helicopter Parking Pad (Construction/CA/RPR) (Amendment) (WBS TBD) This project will construct a new helicopter parking pad. This state aid funding provides the match to federal funding through the Safety Enhancement program. (PR# 4650)	\$9,206 Total \$9,206 State \$0 Local
Division 5 Raleigh Regional Airport Person County	Runway, Connector Taxiways & Apron Pavement Rehabilitation (Construction) WBS 36244.60.9.3 This request will provide initial construction funding for the pavement rehabilitation of the Runway 6/24, associated taxiway connectors and aircraft parking apron. (PR# 3593)	6,500,000 Total 5,850,000 State 650,000 Local

ITEM I-4 SUMMARY – 2 REQUESTS – Total Cost: \$ 6,509,206
Total State Cost \$ 5,859,206
Total Local Investment \$ 650,000

*Costs are estimated. Only eligible costs within the project scope of work will be reimbursed.

May 4, 2023

**NCDOT MAY 2023 BOARD OF TRANSPORTATION AGENDA
APPROVAL OF STRATEGIC TRANSPORTATION INVESTMENT FUNDS**

TOWN / COUNTY DIVISION PROJ. CATEGORY	PROJECT DESCRIPTION	ESTIMATED COST
HYDE DIV. 1 AV-5812 DIVISION	WBS 47169.3.1 HYDE COUNTY AIRPORT (7W6). EXTEND RUNWAY TO 5000 FEET. \$822,000.00 HAS PREVIOUSLY BEEN APPROVED FOR CONSTRUCTION. ADDITIONAL FUNDS ARE REQUESTED.	\$940,000.00
CHOWAN DIV. 1 B-5501WM DIVISION	WBS 55001.4.1 REPLACE BRIDGE # 3 OVER PEMBROOK CREEK ON SR 1200. \$14,896.00 HAS PREVIOUSLY BEEN APPROVED FOR MITIGATION. FUNDS NEED TO BE DECREASED (\$14,896.00). WBS WILL BE CLOSED.	(\$14,896.00)
DARE DIV. 1 B-5610 REGIONAL	WBS 45565.1.2 REPLACE BRIDGE #8 OVER A CANAL ON NC 12. \$508,748.00 HAS PREVIOUSLY BEEN APPROVED FOR PRELIMINARY ENGINEERING. ADDITIONAL FUNDS ARE REQUESTED.	\$100,000.00
CURRITUCK DIV. 1 HS-2001F REGIONAL	WBS 49296.1.8 CONSTRUCT U-TURN BULB OUTS AND MODIFY MEDIAN AT INTERSECTION OF US 158 AND EDGEWATER ROAD. INITIAL FUNDS ARE REQUESTED FOR PRELIMINARY ENGINEERING.	\$400,000.00
CURRITUCK, CAMDEN DIV. 1 R-5717 DIVISION	WBS 50213.1.1 SR 1227/SR 1208 (S. MILLS ROAD) AND SR 1224/SR1223 (OLD SWAMP ROAD) FROM NC 343 IN CAMDEN COUNTY TO NC 168 IN CURRITUCK COUNTY. \$2,243,545.00 HAS PREVIOUSLY BEEN APPROVED FOR PRELIMINARY ENGINEERING. ADDITIONAL FUNDS ARE REQUESTED.	\$460,000.00

**NCDOT MAY 2023 BOARD OF TRANSPORTATION AGENDA
APPROVAL OF STRATEGIC TRANSPORTATION INVESTMENT FUNDS**

TOWN / COUNTY DIVISION PROJ. CATEGORY	PROJECT DESCRIPTION	ESTIMATED COST
PERQUIMANS DIV. 1 R-5740 DIVISION	WBS 50198.1.1 SR 1329 (WOODVILLE ROAD) FROM SR 1331 (RED BANK ROAD) TO SR 1300 (NEW HOPE ROAD). \$1,260,782.00 HAS PREVIOUSLY BEEN APPROVED FOR PRELIMINARY ENGINEERING. RE-OPEN WBS. ADDITIONAL STRATEGIC TRANSPORTATION INVESTMENTS FUNDS ARE REQUESTED. THIS IS A BUILD NC BOND PROJECT.	\$25,000.00
PERQUIMANS DIV. 1 R-5740 DIVISION	WBS 50198.2.2 SR 1329 (WOODVILLE ROAD) FROM SR 1331 (RED BANK ROAD) TO SR 1300 (NEW HOPE ROAD). \$936,000.00 HAS PREVIOUSLY BEEN APPROVED FOR UTILITIES. ADDITIONAL STRATEGIC TRANSPORTATION INVESTMENTS FUNDS ARE REQUESTED. THIS IS A BUILD NC BOND PROJECT.	\$140,000.00
NORTHAMPTON DIV. 1 R-5757 DIVISION	WBS 44709.1.1 NC 305 FROM SEABOARD TOWN LIMITS TO HERTFORD COUNTY LINE. \$3,600,992.00 HAS PREVIOUSLY BEEN APPROVED FOR PRELIMINARY ENGINEERING. ADDITIONAL FUNDS ARE REQUESTED.	\$925,000.00
BERTIE DIV. 1 R-5809A DIVISION	WBS 46976.2.2 NC 45 FROM WASHINGTON COUNTY LINE TO US 17 AT MIDWAY. INITIAL FUNDS ARE REQUESTED FOR FULL RIGHT OF WAY.	\$315,000.00
BERTIE DIV. 1 R-5809A DIVISION	WBS 46976.2.5 NC 45 FROM WASHINGTON COUNTY LINE TO US 17 AT MIDWAY. INITIAL FUNDS ARE REQUESTED FOR UTILITIES.	\$150,000.00
BEAUFORT DIV. 2 B-5614 DIVISION	WBS 45569.1.2 REPLACE BRIDGE 9 OVER BLOUNTS CREEK ON SR 1112. \$886,700.00 HAS PREVIOUSLY BEEN APPROVED FOR PRELIMINARY ENGINEERING. ADDITIONAL FUNDS ARE REQUESTED.	\$175,000.00

MAY 4, 2023

**NCDOT MAY 2023 BOARD OF TRANSPORTATION AGENDA
APPROVAL OF STRATEGIC TRANSPORTATION INVESTMENT FUNDS**

TOWN / COUNTY DIVISION PROJ. CATEGORY	PROJECT DESCRIPTION	ESTIMATED COST
LENOIR DIV. 2 R-2553 STATEWIDE	WBS 34460.1.2 US 70 (KINSTON BYP). \$16,596,858.00 HAS PREVIOUSLY BEEN APPROVED FOR PRELIMINARY ENGINEERING. ADDITIONAL FUNDS ARE REQUESTED. THIS PROJECT HAS PREVIOUSLY BEEN IDENTIFIED AS A TRUST FUNDS INTRASTATE SYSTEM PROJECT.	\$1,500,000.00
CRAVEN DIV. 2 R-5777C STATEWIDE	WBS 44648.1.4 US 70 FROM THURMAN ROAD TO HAVELOCK BYPASS. \$6,830,990.00 HAS PREVIOUSLY BEEN APPROVED FOR PRELIMINARY ENGINEERING. ADDITIONAL FUNDS ARE REQUESTED.	\$100,000.00
CRAVEN DIV. 2 R-5777C STATEWIDE	WBS 44648.2.7 US 70 IMPROVEMENTS FROM THE HAVELOCK BYPASS TO EAST OF SR 1116 (THURMAN ROAD). INITIAL FUNDS ARE REQUESTED FOR UTILITIES. THIS IS A CASH FLOW PROJECT WITH \$100,000.00 IN SFY 23, \$10,000,00.00 IN SFY 24 AND \$10, 486,080 IN SFY 25.	\$20,586,080.00
JONES, ON SLOW DIVS. 2/3 R-2514B STATEWIDE	WBS 34442.3.7 US 17 FROM SOUTH OF BELGRADE TO NORTH OF MAYSVILLE. \$157,617,444.00 HAS PREVIOUSLY BEEN APPROVED FOR CONSTRUCTION. ADDITIONAL FUNDS ARE REQUESTED. THIS IS A STRATEGIC TRANSPORTATION INVESTMENTS TRANSITION PROJECT.	\$6,000.00
GREENE, WAYNE DIVS. 2/4 R-5853 DIVISION	WBS 47541.1.1 US 13 FROM SR 1572 (SAULSTON ROAD) TO SR 1700 (RODELL BARROW ROAD). \$644,919.00 HAS PREVIOUSLY BEEN APPROVED FOR PRELIMINARY ENGINEERING. ADDITIONAL FUNDS ARE REQUESTED.	\$100,000.00

**NCDOT MAY 2023 BOARD OF TRANSPORTATION AGENDA
APPROVAL OF STRATEGIC TRANSPORTATION INVESTMENT FUNDS**

TOWN / COUNTY DIVISION PROJ. CATEGORY	PROJECT DESCRIPTION	ESTIMATED COST
NEW HANOVER DIV. 3 HB-0039 STATEWIDE	WBS 50603.2.3 REPLACE BRIDGE 13 OVER CAPE FEAR RIVER ON US 421 \$50,000.00 HAS PREVIOUSLY BEEN APPROVED FOR ADVANCED PROPERTY ACQUISITION / RELOCATION STUDIES OF SPECIFIC PARCELS. ADDITIONAL FUNDS ARE REQUESTED FOR ADVANCED ACQUISITION OF SPECIFIC PARCEL 900.	\$18,372,000.00
PENDER, NEW HANOVER DIV. 3 I-6039 STATEWIDE	WBS 47988.1.1 I-40 FROM MILEMARKER 420 TO NC 210 (MILEMARKER 408). INITIAL FUNDS ARE REQUESTED FOR PRELIMINARY ENGINEERING.	\$200,000.00
PENDER, NEW HANOVER DIV. 3 R-3300A REGIONAL	WBS 40237.2.4 US 17 HAMPSTEAD BYPASS FROM US 17 BYPASS SOUTH OF HAMPSTEAD TO NC 210. \$107,315,000.00 HAS PREVIOUSLY BEEN APPROVED FOR FULL RIGHT OF WAY AND UTILITIES. RIGHT OF WAY SPENDING HAS NOT OCCURRED AS QUICKLY AS ORIGINALLY ANTICIPATED, THEREFORE, THE CURRENT FUNDING AVAILABLE IN SFY 2023 WILL BE DECREASED BY \$10,000,000.00 AND MADE AVAILABLE TO OTHER PROJECTS. \$5,000,000.00 WILL BE CASH-FLOWED FROM SFY 2025 AND \$5,000,000.00 WILL BE CASH- FLOWED FROM SFY 2026 TO BETTER ALIGN FUNDING AND EXPENDITURES.	\$0.00

**NCDOT MAY 2023 BOARD OF TRANSPORTATION AGENDA
APPROVAL OF STRATEGIC TRANSPORTATION INVESTMENT FUNDS**

TOWN / COUNTY DIVISION PROJ. CATEGORY	PROJECT DESCRIPTION	ESTIMATED COST
PENDER DIV. 3 R-3300B REGIONAL	WBS 40237.2.5 NC 417 (HAMPSTEAD BYPASS) FROM NC 210 TO US 17 NORTH OF HAMPSTEAD. \$109,493,313.00 HAS PREVIOUSLY BEEN APPROVED FOR FULL RIGHT OF WAY AND UTILITIES. RIGHT OF WAY SPENDING HAS NOT OCCURRED AS QUICKLY AS ORIGINALLY ANTICIPATED, THEREFORE, THE CURRENT FUNDING AVAILABLE IN SFY 2023 WILL BE DECREASED BY \$5,000,000.00 AND MADE AVAILABLE TO OTHER PROJECTS. \$5,000,000.00 WILL BE CASH-FLOWED FROM SFY 2025 TO BETTER ALIGN FUNDING AND EXPENDITURES.	\$0.00
PENDER DIV. 3 R-3300B REGIONAL	WBS 40237.1.5 US 17 (HAMPSTEAD BYPASS) FROM NC 210 TO US 17 NORTH OF HAMPSTEAD. INITIAL FUNDS ARE REQUESTED FOR PRELIMINARY ENGINEERING.	\$150,000.00
PENDER DIV. 3 R-5899 REG/DIV	WBS 48355.1.1 NC 210 AT SR 1560 (WATTS LANDING ROAD). \$4,816.00 HAS PREVIOUSLY BEEN APPROVED FOR PRELIMINARY ENGINEERING. ADDITIONAL FUNDS ARE REQUESTED USING DIVISION TIER FUNDING.	\$750,000.00
PENDER DIV. 3 R-5900 DIVISION	WBS 48356.1.2 NC 50/NC 210 AT SR 1534 (BELT ROAD). INITIAL FUNDS ARE REQUESTED FOR PRELIMINARY ENGINEERING.	\$750,000.00
ONSLOW DIV. 3 U-5508 STATEWIDE	WBS 50015.1.2 NC 24 (LEJEUNE BLVD) AT NC 53 (WESTERN BLVD). \$622,395.00 HAS PREVIOUSLY BEEN APPROVED FOR PRELIMINARY ENGINEERING. ADDITIONAL FUNDS ARE REQUESTED.	\$100,000.00

**NCDOT MAY 2023 BOARD OF TRANSPORTATION AGENDA
APPROVAL OF STRATEGIC TRANSPORTATION INVESTMENT FUNDS**

TOWN / COUNTY DIVISION PROJ. CATEGORY	PROJECT DESCRIPTION	ESTIMATED COST
PENDER DIV. 3 U-5732 REGIONAL	WBS 54023.2.1 US 17 FROM SR 1582 (WASHINGTON ACRES ROAD) TO VISTA LANE. \$31,220,000.00 HAS PREVIOUSLY BEEN APPROVED FOR FULL RIGHT OF WAY AND UTILITIES. FUNDS NEED TO BE DECREASED (\$19,537,149.88). WBS WILL BE CLOSED.	(\$19,537,149.88)
NASH DIV. 4 U-2561C DIVISION	WBS 34835.1.5 NC 43 FROM SR 1613 (WOODRUFF AVENUE) TO I-95. \$374,535.00 HAS PREVIOUSLY BEEN APPROVED FOR PRELIMINARY ENGINEERING. ADDITIONAL FUNDS ARE REQUESTED.	\$100,000.00
EDGECOMBE DIV. 4 U-4424 DIVISION	WBS 39062.1.2 NC 111 (WILSON STREET) FROM US 64 ALTERNATE (WESTERN BOULEVARD) TO NC 122 (MCNAIR ROAD). \$2,075,981.00 HAS PREVIOUSLY BEEN APPROVED FOR PRELIMINARY ENGINEERING. ADDITIONAL FUNDS ARE REQUESTED.	\$200,000.00
EDGECOMBE DIV. 4 U-4424 DIVISION	WBS 39062.3.2 NC 111 (WILSON STREET) FROM US 64 ALTERNATE (WESTERN BOULEVARD) TO NC 122 (MCNAIR ROAD). INITIAL FUNDS ARE REQUESTED FOR CONSTRUCTION BASED ON THE 12-MONTH TENTATIVE LETTING LIST PUBLISHED APRIL 11, 2023. THIS IS A CASH FLOW PROJECT WITH \$200,000.00 IN SFY 23, \$8,600,000.00 IN SFY 24, \$8,000,000.00 IN SFY 25 AND \$3,200,000.00 IN SFY 26.	\$20,000,000.00
JOHNSTON DIV. 4 U-5998 DIVISION	WBS 47135.1.1 NC 42 FROM SR 1003 (BUFFALO ROAD) TO WILSON COUNTY LINE. \$119,917.00 HAS PREVIOUSLY BEEN APPROVED FOR PRELIMINARY ENGINEERING. ADDITIONAL FUNDS ARE REQUESTED.	\$400,000.00

MAY 4, 2023

**NCDOT MAY 2023 BOARD OF TRANSPORTATION AGENDA
APPROVAL OF STRATEGIC TRANSPORTATION INVESTMENT FUNDS**

TOWN / COUNTY DIVISION PROJ. CATEGORY	PROJECT DESCRIPTION	ESTIMATED COST
WAYNE DIV. 4 U-6110 REGIONAL	WBS 48334.1.1 US 70 (FUTURE I-42) AT SR 1711 (NORTH OAK FOREST ROAD). \$10,000.00 HAS PREVIOUSLY BEEN APPROVED FOR PRELIMINARY ENGINEERING. ADDITIONAL FUNDS ARE REQUESTED.	\$300,000.00
DURHAM DIV. 5 HE-0007B DIVISION	WBS 50476.1.3 SR 1794 (TEKNIKA PARKWAY) AT SR 1632 (RED MILL ROAD). \$340,000.00 HAS PREVIOUSLY BEEN APPROVED FOR PRELIMINARY ENGINEERING. ADDITIONAL FUNDS ARE REQUESTED. THIS IS AN ECONOMIC DEVELOPMENT PROJECT.	\$200,000.00
DURHAM DIV. 5 HE-0007C DIVISION	WBS 50476.1.4 SR 2635 (INTERNATIONAL DRIVE) FROM SR 1004 (OLD OXFORD ROAD) TO NEW LOCATION. \$100,000.00 HAS PREVIOUSLY BEEN APPROVED FOR PRELIMINARY ENGINEERING. ADDITIONAL FUNDS ARE REQUESTED. THIS IS AN ECONOMIC DEVELOPMENT PROJECT.	\$425,000.00
WAKE DIV. 5 HL-0006 BONUSALLOC	WBS 49365.1.1 US 401, SR 1393 (HILLTOP-NEEDMORE ROAD) /SR 2751 (HILLTOP ROAD) AT SR 2752 (AIR PARK ROAD) INTERSECTION AND SR1375 (LAKE WHEELER ROAD) INTERSECTION IN FUQUAY-VARINA. \$1,520,000.00 HAS PREVIOUSLY BEEN APPROVED FOR PRELIMINARY ENGINEERING. ADDITIONAL FUNDS ARE REQUESTED.	\$1,000,000.00
WAKE DIV. 5 HL-0007 BONUSALLOC	WBS 49366.1.1 NC 55 AT SR 1191 (TECHNOLOGY DRIVE) / SR 6107 (EAST WILLIAMS STREET) IN APEX. \$1,665,000.00 HAS PREVIOUSLY BEEN APPROVED FOR PRELIMINARY ENGINEERING. ADDITIONAL FUNDS ARE REQUESTED.	\$750,000.00
WAKE DIV. 5 HL-0008O BONUSALLOC	WBS 49367.2.11 NC 42 AT SR 2735 (JOHNSTON ROAD). INITIAL FUNDS ARE REQUESTED FOR FULL RIGHT OF WAY.	\$175,000.00

MAY 4, 2023

**NCDOT MAY 2023 BOARD OF TRANSPORTATION AGENDA
APPROVAL OF STRATEGIC TRANSPORTATION INVESTMENT FUNDS**

TOWN / COUNTY DIVISION PROJ. CATEGORY	PROJECT DESCRIPTION	ESTIMATED COST
DURHAM DIV. 5 P-5706 SW/REG	WBS 46918.1.1 NORFOLK SOUTHERN H LINE, EAST DURHAM RAILROAD SAFETY PROJECT.PROJECT WILL STRAIGHTEN EXISTING RAILROAD CURVATURE BETWEEN CP NELSON AND CP EAST DURHAM AND INCLUDES A COMBINATION OF GRADE SEPARATIONS ANDCLOSURES AT ELLIS ROAD SOUTH END CROSSING (734737A), GLOVER ROAD (734735L), AND WRENN ROAD (734736T) IN DURHAM. \$2,928,000.00 HAS PREVIOUSLY BEEN APPROVED FOR PRELIMINARY ENGINEERING. ADDITIONAL FUNDS ARE REQUESTED USING STATEWIDE TIER FUNDING.	\$600,000.00
WAKE DIV. 5 U-5301 STATEWIDE	WBS 47018.1.7 US 64 FROM WEST OF SR 1308 (LAURA DUNCAN ROAD) TO US 1. INITIAL FUNDS ARE REQUESTED FOR PRELIMINARY ENGINEERING.	\$2,500,000.00
WAKE DIV. 5 W-5601WM STATEWIDE	WBS 50138.4.1 MITIGATION FOR SFY 2022. \$42,541.00 HAS PREVIOUSLY BEEN APPROVED FOR WETLAND MITIGATION. FUNDS NEED TO BE DECREASED (\$42,541.00). WBS WILL BE CLOSED.	(\$42,541.00)
CUMBERLAND DIV. 6 I-5986A STATEWIDE	WBS 47532.1.2 I-95 FROM I-95 BUSINESS/US 301 (EXIT 56) TO SR 1001 (LONGBRANCH ROAD - EXIT 71). \$4,919,269.00 HAS PREVIOUSLY BEEN APPROVED FOR PRELIMINARY ENGINEERING. ADDITIONAL FUNDS ARE REQUESTED.	\$100,000.00
ROBESON, CUMBERLAND DIV. 6 I-5987WM REGIONAL	WBS 47533.4.1 SFY 2022 MITIGATION FOR I-5987A & B. \$3,794,355.00 HAS PREVIOUSLY BEEN APPROVED FOR WETLAND MITIGATION. ADDITIONAL FUNDS ARE REQUESTED. WBS WILL BE CLOSED.	\$99,032.67

MAY 4, 2023

**NCDOT MAY 2023 BOARD OF TRANSPORTATION AGENDA
APPROVAL OF STRATEGIC TRANSPORTATION INVESTMENT FUNDS**

TOWN / COUNTY DIVISION PROJ. CATEGORY	PROJECT DESCRIPTION	ESTIMATED COST
CUMBERLAND DIV. 6 U-5101A DIVISION	WBS 41899.1.2 SR 1437 (SHAW RD) FROM NC 24/NC 87 (BRAGG BLVD) TO NC 210 (MURCHISON ROAD). \$283,573.00 HAS PREVIOUSLY BEEN APPROVED FOR PRELIMINARY ENGINEERING. ADDITIONAL FUNDS ARE REQUESTED.	\$600,000.00
GUILFORD DIV. 7 P-5709 REGIONAL	WBS 46920.1.1 NORFOLK SOUTHERN RAILROAD H LINE. \$2,550,000.00 HAS PREVIOUSLY BEEN APPROVED FOR PRELIMINARY ENGINEERING. ADDITIONAL FUNDS ARE REQUESTED.	\$600,000.00
GUILFORD DIV. 7 P-5709 REGIONAL	WBS 46920.2.1 NORFOLK SOUTHERN RAILROAD H LINE. \$2,500,000.00 HAS PREVIOUSLY BEEN APPROVED FOR FULL RIGHT OF WAY. ADDITIONAL FUNDS ARE REQUESTED.	\$984,000.00
GUILFORD DIV. 7 P-5709 REGIONAL	WBS 46920.2.2 NORFOLK SOUTHERN RAILROAD H LINE. \$919,000.00 HAS PREVIOUSLY BEEN APPROVED FOR UTILITIES. ADDITIONAL FUNDS ARE REQUESTED.	\$647,000.00
GUILFORD DIV. 7 R-4707 REGIONAL	WBS 36599.3.1 US 29 AT SR 4771 (REEDY FORK PARKWAY) INTERCHANGE IN GREENSBORO. \$54,377,192.00 HAS PREVIOUSLY BEEN APPROVED FOR CONSTRUCTION. CONSTRUCTION SPENDING HAS NOT OCCURRED AS QUICKLY AS ORIGINALLY ANTICIPATED, THEREFORE, THE CURRENT FUNDING AVAILABLE IN SFY2023WILL BE DECREASED BY \$10,000,000.00 AND MADE AVAILABLE TO OTHER PROJECTS. \$10,000,000.00 WILL BE CASH-FLOWED FROM SFY 2025 TO BETTER ALIGN FUNDING AND EXPENDITURES. THIS IS A BUILD NC BOND PROJECT.	\$0.00

**NCDOT MAY 2023 BOARD OF TRANSPORTATION AGENDA
APPROVAL OF STRATEGIC TRANSPORTATION INVESTMENT FUNDS**

TOWN / COUNTY DIVISION PROJ. CATEGORY	PROJECT DESCRIPTION	ESTIMATED COST
GUILFORD DIV. 7 R-5725 REGIONAL	WBS 50474.3.1 INTERSECTION IMPROVEMENTS ALONG NC 68 AND NC 150 IN OAK RIDGE. INITIAL FUNDS ARE REQUESTED FOR CONSTRUCTION BASED ON THE 12-MONTH TENTATIVE LETTING LIST PUBLISHED APRIL 11, 2023. THIS IS A CASH FLOW PROJECT WITH \$300,000.00 IN SFY 23, \$5,000,000.00 IN SFY 24 AND \$2,000,000.00 IN SFY 25.	\$7,300,000.00
GUILFORD DIV. 7 U-2525C STATEWIDE	WBS 34821.3.7 GREENSBORO EASTERN LOOP FROM US 29 NORTH OF GREENSBORO TO SR 2303 (LAWNDALE DRIVE). \$184,708,322.00 HAS PREVIOUSLY BEEN APPROVED FOR CONSTRUCTION. ADDITIONAL STRATEGIC TRANSPORTATION INVESTMENTS FUNDS ARE REQUESTED. THIS IS A BUILD NC BOND PROJECT. THIS IS A CASH FLOW PROJECT WITH \$3,000,000.00 IN SFY 23 AND \$12,000,000.00 IN SFY 24.	\$15,000,000.00
GUILFORD DIV. 7 U-5841 DIVISION	WBS 50232.3.1 FRIENDLY AVENUE FROM WEST OF GREEN VALLEY ROAD TO LINDELL ROAD IN GREENSBORO. \$1,500,000.00 HAS PREVIOUSLY BEEN APPROVED FOR CONSTRUCTION. ADDITIONAL FUNDS ARE REQUESTED.	\$700,000.00
SCOTLAND DIV. 8 HE-0013A DIVISION	WBS 50700.3.2 IMPROVE CONSTRUCTION ACCESS ROAD INTO THE SCOTLAND COUNTY INDUSTRIAL PARK. INITIAL FUNDS ARE REQUESTED FOR CONSTRUCTION. THIS IS AN ECONOMIC DEVELOPMENT PROJECT.	\$200,000.00

**NCDOT MAY 2023 BOARD OF TRANSPORTATION AGENDA
APPROVAL OF STRATEGIC TRANSPORTATION INVESTMENT FUNDS**

TOWN / COUNTY DIVISION PROJ. CATEGORY	PROJECT DESCRIPTION	ESTIMATED COST
MONTGOMERY DIV. 8 R-2527 SW/REG	WBS 35572.1.1 NC 24-27 FROM NC 73 TO THE TROY BYPASS. \$8,999,624.00 HAS PREVIOUSLY BEEN APPROVED FOR PRELIMINARY ENGINEERING. ADDITIONAL STRATEGIC TRANSPORTATION INVESTMENTS FUNDS ARE REQUESTED. THIS PROJECT HAS PREVIOUSLY BEEN IDENTIFIED AS A TRUST FUND INTRASTATE SYSTEM PROJECT. THIS IS A BUILD NC BOND PROJECT.	\$250,000.00
MOORE DIV. 8 R-5892 REGIONAL	WBS 48398.1.1 NC 5 (BEULAH HILL ROAD) FROM INTERSECTION OF TROTTER DRIVE/BLAKE BOULEVARD TO NC 211 IN PINEHURST. \$19,453.00 HAS PREVIOUSLY BEEN APPROVED FOR PRELIMINARY ENGINEERING. ADDITIONAL FUNDS ARE REQUESTED.	\$750,000.00
MOORE DIV. 8 R-5927 DIVISION	WBS 48544.1.1 US 15/ US 501 FROM NC 2 AND NC 211 TRAFFIC CIRCLE IN PINEHURST TO NC 73. \$501,601.00 HAS PREVIOUSLY BEEN APPROVED FOR PRELIMINARY ENGINEERING. ADDITIONAL FUNDS ARE REQUESTED.	\$150,000.00
CHATHAM DIV. 8 R-5930 DIVISION	WBS 48548.1.1 NEW ROUTE FROM US 64 BYPASS IN PITTSBORO TO US 15 / US 501. \$4,260,000.00 HAS PREVIOUSLY BEEN APPROVED FOR PRELIMINARY ENGINEERING. ADDITIONAL FUNDS ARE REQUESTED.	\$200,000.00
HOKE DIV. 8 U-5753 DIVISION	WBS 51078.1.1 SR 1305 (WAYSIDE ROAD) FROM US 401 TO PLANK ROAD AND SR 1418 FROM US 401 TO SR 1406 (ROCKFISH ROAD). \$3,301,867.00 HAS PREVIOUSLY BEEN APPROVED FOR PRELIMINARY ENGINEERING. ADDITIONAL FUNDS ARE REQUESTED.	\$500,000.00

**NCDOT MAY 2023 BOARD OF TRANSPORTATION AGENDA
APPROVAL OF STRATEGIC TRANSPORTATION INVESTMENT FUNDS**

TOWN / COUNTY DIVISION PROJ. CATEGORY	PROJECT DESCRIPTION	ESTIMATED COST
RANDOLPH DIV. 8 U-5770A REGIONAL	WBS 54036.3.2 I-85 FROM WEST OF COLUMBUS AVENUE TO SR 3182 (COMANCHE ROAD/TARHEEL ROAD). INITIAL FUNDS ARE REQUESTED FOR CONSTRUCTION.	\$1,693,000.00
DAVIDSON DIV. 9 HE-0014 DIVISION	WBS 50802.1.1 SR 1104 (OLD LINWOOD ROAD). CONSTRUCT NEW ACCESS ROAD NORTH OF SR 1254 (BROWN STREET) AND IMPROVEMENTS TO SR 1104 (OLD LINWOOD ROAD). INITIAL FUNDS ARE REQUESTED FOR PRELIMINARY ENGINEERING.	\$400,000.00
STOKES DIV. 9 R-5768WM DIVISION	WBS 44670.4.4 US 311 (SOUTH MAIN STREET) AT NC 65 AND SR 1928 (STOKESBURG ROAD) AND NC 65 AT NORFOLK SOUTHERN RAIL CROSSING 470 180V IN WALNUT COVE. \$18,996.00 HAS PREVIOUSLY BEEN APPROVED FOR MITIGATION. FUNDS NEED TO BE DECREASED (\$18,996.00). WBS WILL BE CLOSED.	(\$18,996.00)
FORSYTH DIV. 9 U-2729 DIVISION	WBS 34853.3.3 SR 1672 (HANES MILL ROAD) FROM MUSEUM DRIVE TO SR 4000 (UNIVERSITY PARKWAY) IN WINSTON-SALEM. INITIAL FUNDS ARE REQUESTED FOR CONSTRUCTION BASED ON THE 12-MONTH TENTATIVE LETTING LIST PUBLISHED APRIL 11, 2023. THIS IS A CASH FLOW PROJECT WITH \$177,000.00 IN SFY 23, \$6,923,000.00 IN SFY 24, \$6,772,000.00 IN SFY 25 AND \$3,728,000.00 IN SFY 26.	\$17,600,000.00

**NCDOT MAY 2023 BOARD OF TRANSPORTATION AGENDA
APPROVAL OF STRATEGIC TRANSPORTATION INVESTMENT FUNDS**

TOWN / COUNTY DIVISION PROJ. CATEGORY	PROJECT DESCRIPTION	ESTIMATED COST
FORSYTH DIV. 9 U-5536 DIVISION	WBS 44108.2.1 LEWISVILLE - GREAT WAGON ROAD (NEW ROUTE) FROM SR 1001 (SHALLOWFORD ROAD) TO SR 1308 (LEWISVILLE-VIENNA ROAD). \$14,500,000.00 HAS PREVIOUSLY BEEN APPROVED FOR FULL RIGHT OF WAY. RIGHT OF WAY SPENDING HAS NOT OCCURRED AS QUICKLY AS ORIGINALLY ANTICIPATED, THEREFORE, THE CURRENT FUNDING AVAILABLE IN SFY 2023 WILL BE DECREASED BY \$5,000,000.00 AND MADE AVAILABLE TO OTHER PROJECTS. \$5,000,000.00 WILL BE CASH-FLOWED FROM SFY 2025 TO BETTER ALIGN FUNDING AND EXPENDITURES.	\$0.00
ROWAN DIV. 9 U-5738WM DIVISION	WBS 50163.4.1 MITIGATION FOR SFY 2022. \$325,910.00 HAS PREVIOUSLY BEEN APPROVED FOR WETLAND MITIGATION. FUNDS NEED TO BE DECREASED (\$325,910.00). WBS WILL BE CLOSED.	(\$325,910.00)
FORSYTH DIV. 9 U-5824 DIVISION	WBS 44395.1.1 NC 66 (OLD HOLLOW ROAD) FROM HARLEY DRIVE TO US 158 IN WALKERTOWN. \$2,149,240.00 HAS PREVIOUSLY BEEN APPROVED FOR PRELIMINARY ENGINEERING. ADDITIONAL FUNDS ARE REQUESTED.	\$350,000.00
FORSYTH DIV. 9 U-6003 DIVISION	WBS 47138.2.1 NEW ROUTE FROM SR 1969 (PINEY GROVE ROAD) TO NC 150 (NORTH MAIN STREET) IN KERNERSVILLE. \$2,000,000.00 HAS PREVIOUSLY BEEN APPROVED FOR FULL RIGHT OF WAY AND UTILITIES. ADDITIONAL FUNDS ARE REQUESTED.	\$2,000,000.00
FORSYTH DIV. 9 U-6004 DIVISION	WBS 47139.1.1 SR 1103 (LEWISVILLE-CLEMMONS ROAD) FROM US 158 TO SR 1891 (PEACE HAVEN ROAD) IN CLEMMONS. \$1,885,000.00 HAS PREVIOUSLY BEEN APPROVED FOR PRELIMINARY ENGINEERING. ADDITIONAL FUNDS ARE REQUESTED.	\$1,100,000.00

MAY 4, 2023

**NCDOT MAY 2023 BOARD OF TRANSPORTATION AGENDA
APPROVAL OF STRATEGIC TRANSPORTATION INVESTMENT FUNDS**

TOWN / COUNTY DIVISION PROJ. CATEGORY	PROJECT DESCRIPTION	ESTIMATED COST
ANSON DIV. 10 B-4410A DIVISION	WBS 33688.3.2 SR 1657 (PINKSTON ROAD). INSTALL WATERLINE IN TOWN OF ANSONVILLE PER UTILITY CONSTRUCTION AGREEMENT. \$366,800.00 HAS PREVIOUSLY BEEN APPROVED FOR CONSTRUCTION. ADDITIONAL FUNDS ARE REQUESTED. THIS IS A STRATEGIC TRANSPORTATION INVESTMENTS TRANSITION PROJECT.	\$435,000.00
CABARRUS DIV. 10 HE-0015 DIVISION	WBS 50803.3.1 NC 49 AT PRINCE CIRCLE TO WEST OF GENERAL SERVICES DRIVE SW. INITIAL FUNDS ARE REQUESTED FOR CONSTRUCTION.	\$2,000,000.00
MECKLENBURG DIV. 10 HL-0023 BONUSALLOC	WBS 49489.2.1 REA ROAD FROM I-485 OUTER LOOP TO WILLIAMS POND LANE. INITIAL FUNDS ARE REQUESTED FOR FULL RIGHT OF WAY.	\$778,856.00
UNION DIV. 10 P-5748 REGIONAL	WBS 48336.1.1 CSX SG RAIL LINE. \$3,150,000.00 HAS PREVIOUSLY BEEN APPROVED FOR PRELIMINARY ENGINEERING. ADDITIONAL FUNDS ARE REQUESTED.	\$600,000.00
ANSON DIV. 10 P-5750 REGIONAL	WBS 48335.1.1 CSX SF RAIL LINE. \$1,750,000.00 HAS PREVIOUSLY BEEN APPROVED FOR PRELIMINARY ENGINEERING. ADDITIONAL FUNDS ARE REQUESTED.	\$600,000.00
STANLY DIV. 10 R-5965A DIVISION	WBS 49190.3.2 NC 205/SR 1108 (LIGHTHOUSE ROAD) AT SR 1109 (BUSTER ROAD) INTERSECTION AND SR 1110 (SWIFT ROAD) AT CHARLOTTE PIPE FACILITY. \$1,140,000.00 HAS PREVIOUSLY BEEN APPROVED FOR CONSTRUCTION. ADDITIONAL FUNDS ARE REQUESTED. THIS IS AN ECONOMIC DEVELOPMENT PROJECT.	\$50,000.00

MAY 4, 2023

**NCDOT MAY 2023 BOARD OF TRANSPORTATION AGENDA
APPROVAL OF STRATEGIC TRANSPORTATION INVESTMENT FUNDS**

TOWN / COUNTY DIVISION PROJ. CATEGORY	PROJECT DESCRIPTION	ESTIMATED COST
STANLY DIV. 10 R-5965B DIVISION	WBS 49190.3.3 VARIOUS IMPROVEMENTS AROUND TOWN OF OAKBORO AT SR 1107 (SILVER ROAD)/SR 1108 (LIGHTHOUSE ROAD) AND SR 1107(SILVER ROAD)/ SR 1110 (SWIFT ROAD) INTERSECTIONS. IMPROVE INTERSECTIONS AT SR 1107 (SILVER ROAD), SR 1108 (LIGHTHOUSE ROAD) AND SR 1110 (SWIFT ROAD). \$2,820,000.00 HAS PREVIOUSLY BEEN APPROVED FOR CONSTRUCTION. FUNDS NEED TO BE DECREASED (\$179,721.00).	(\$179,721.00)
MECKLENBURG DIV. 10 U-4713A DIVISION	WBS 39077.1.2 SR 3440 (MCKEE ROAD EXTENSION) FROM SR 3448 (PLEASANT PLAINS ROAD) TO SR 1009 (JOHN STREET). \$1,511,698.00 HAS PREVIOUSLY BEEN APPROVED FOR PRELIMINARY ENGINEERING. ADDITIONAL STRATEGIC TRANSPORTATION INVESTMENTS FUNDS ARE REQUESTED. THIS IS A BUILD NC BOND PROJECT.	\$280,000.00
UNION DIV. 10 U-5808 DIVISION	WBS 44381.1.1 SR 1362 (CHESNUT LANE CONNECTOR) FROM SR 1367 (MATTHEWS INDIAN TRAIL ROAD) TO SR 1368 (GRIBBLE ROAD). \$2,425,000.00 HAS PREVIOUSLY BEEN APPROVED FOR PRELIMINARY ENGINEERING. ADDITIONAL FUNDS ARE REQUESTED.	\$100,000.00
CALDWELL DIV. 11 U-6033 DIVISION	WBS 46967.3.1 US 64 / NC 18 AND SR 1142 (CALLICO ROAD). INITIAL FUNDS ARE REQUESTED FOR CONSTRUCTION.	\$2,740,000.00
LINCOLN DIV. 12 R-5712 REGIONAL	WBS 50208.1.1 NC 16 BUSINESS AT INTERSECTION OF NC 16 BUSINESS AND SR 1439 (UNITY CHURCH ROAD)/SR 1387 (TRIANGLE CIRCLE). \$558,682.00 HAS PREVIOUSLY BEEN APPROVED FOR PRELIMINARY ENGINEERING. ADDITIONAL FUNDS ARE REQUESTED.	\$125,000.00

MAY 4, 2023

**NCDOT MAY 2023 BOARD OF TRANSPORTATION AGENDA
APPROVAL OF STRATEGIC TRANSPORTATION INVESTMENT FUNDS**

TOWN / COUNTY DIVISION PROJ. CATEGORY	PROJECT DESCRIPTION	ESTIMATED COST
CATAWBA DIV. 12 U-2530A REG/DIV	WBS 34824.1.3 NC 127 FROM SR 1132 (HUFFMAN FARM ROAD) TO SR 1008 (ZION CHURCH ROAD). \$2,057,030.00 HAS PREVIOUSLY BEEN APPROVED FOR PRELIMINARY ENGINEERING. ADDITIONAL FUNDS ARE REQUESTED.	\$800,000.00
IREDELL DIV. 12 U-5964 REGIONAL	WBS 45978.1.1 US 64 (DAVIE AVENUE) AND US 21 (SULLIVAN ROAD). \$899,361.00 HAS PREVIOUSLY BEEN APPROVED FOR PRELIMINARY ENGINEERING. ADDITIONAL FUNDS ARE REQUESTED.	\$300,000.00
GASTON DIV. 12 U-5965 REGIONAL	WBS 45979.1.1 US 29 (FRANKLIN BOULEVARD) AND NC 274. \$800,000.00 HAS PREVIOUSLY BEEN APPROVED FOR PRELIMINARY ENGINEERING. ADDITIONAL FUNDS ARE REQUESTED.	\$150,000.00
GASTON DIV. 12 U-6078 DIVISION	WBS 47525.1.1 INTERSECTION OF NC 275 AND NC 274, INTERSECTION OF NC 275 AND SR 1327 (FAIRVIEW ROAD), AND INTERSECTION OF SR 1456 (WHITEJENKINS ROAD), AND SR 1327 (FAIRVIEW ROAD). \$645,770.00 HAS PREVIOUSLY BEEN APPROVED FOR PRELIMINARY ENGINEERING. ADDITIONAL FUNDS ARE REQUESTED.	\$150,000.00
BUNCOMBE DIV. 13 B-4443 STATEWIDE	WBS 38369.1.2 REPLACE BRIDGES 345 & 346 OVER SR 1839 ON US 19/23, US 25, & US 70. INITIAL FUNDS ARE REQUESTED FOR PRELIMINARY ENGINEERING.	\$1,500,000.00
BUNCOMBE DIV. 13 I-2513B STATEWIDE	WBS 34165.2.20 I-26 FROM SR 3548 (HAYWOOD ROAD) TO SR 1781 (BROADWAY). \$4,015,473.00 HAS PREVIOUSLY BEEN APPROVED FOR ADVANCED ACQUISITION. ADDITIONAL FUNDS ARE REQUESTED FOR ADVANCED ACQUISITION OF SPECIFIC PARCEL 397 (PROPERTY OF RIVERSIDE PARTNERS, LLC).	\$2,221,451.50

MAY 4, 2023

**NCDOT MAY 2023 BOARD OF TRANSPORTATION AGENDA
APPROVAL OF STRATEGIC TRANSPORTATION INVESTMENT FUNDS**

TOWN / COUNTY DIVISION PROJ. CATEGORY	PROJECT DESCRIPTION	ESTIMATED COST
MADISON DIV. 13 I-5831 STATEWIDE	WBS 53037.1.1 I-26 FROM TENNESSEE STATE LINE TO MILE MARKER 9. \$177,417.00 HAS PREVIOUSLY BEEN APPROVED FOR PRELIMINARY ENGINEERING. ADDITIONAL FUNDS ARE REQUESTED. WBS WILL BE CLOSED.	\$1,590.48
RUTHERFORD DIV. 13 R-2233WM DIVISION	WBS 34400.4.2 MITIGATION FOR SFY 2022. \$6,990,278.00 HAS PREVIOUSLY BEEN APPROVED FOR WETLAND MITIGATION. FUNDS NEED TO BE DECREASED (\$6,990,278.00). WBS WILL BE CLOSED.	(\$6,990,278.00)
BURKE DIV. 13 R-3430C DIVISION	WBS 34544.1.5 SR 1001 (CONNELLY SPRINGS ROAD) FROM CATAWBA RIVER TO SR 1933 (SOUTH-WEST BOULEVARD). INITIAL FUNDS ARE REQUESTED FOR PRELIMINARY ENGINEERING.	\$1,000,000.00
MACON DIV. 14 R-5734A DIVISION	WBS 50192.3.1 US 23/US 441 FROM US 64 TO SR 1652 (WIDE HORIZON DRIVE)/SR 1152(BELDEN CIRCLE). \$16,830,405.00 HAS PREVIOUSLY BEEN APPROVED FOR CONSTRUCTION. ADDITIONAL STRATEGIC TRANSPORTATION INVESTMENTS FUNDS ARE REQUESTED. THIS IS A BUILD NC BOND PROJECT.	\$662,200.00
CHEROKEE DIV. 14 R-5908 DIVISION	WBS 48469.1.1 US 19/US 74/US 129 FROM US 64 TO SR 1689 (CASINO PARKWAY). \$250,152.00 HAS PREVIOUSLY BEEN APPROVED FOR PRELIMINARY ENGINEERING. ADDITIONAL FUNDS ARE REQUESTED.	\$800.00

**NCDOT MAY 2023 BOARD OF TRANSPORTATION AGENDA
APPROVAL OF STRATEGIC TRANSPORTATION INVESTMENT FUNDS**

TOWN / COUNTY DIVISION PROJ. CATEGORY	PROJECT DESCRIPTION	ESTIMATED COST
HENDERSON DIV. 14 U-5840 DIVISION	WBS 50231.2.1 SR 1547 (OLD AIRPORT ROAD) FROM US 25 TO MILLS GAP ROAD. \$2,443,160.00 HAS PREVIOUSLY BEEN APPROVED FOR FULL RIGHT OF WAY AND UTILITIES. ADDITIONAL STRATEGIC TRANSPORTATION INVESTMENTS FUNDS ARE REQUESTED. THIS IS A BUILD NC BOND PROJECT.	\$513,812.00
STATEWIDE M-0194A STATEWIDE	WBS 34263.1.6 REALIGNING DOUGLASS GATE FEASIBILITY STUDY FOR JUMPO. \$10,000.00 HAS PREVIOUSLY BEEN APPROVED FOR PRELIMINARY ENGINEERING. ADDITIONAL FUNDS ARE REQUESTED.	\$2,846.00
STATEWIDE RC-2000 STATEWIDE	WBS 49802.1.1 TRAFFIC SEPARATION STUDY IMPLEMENTATION AND CLOSURES PROGRAM. \$250,000.00 HAS PREVIOUSLY BEEN APPROVED FOR PRELIMINARY ENGINEERING. ADDITIONAL FUNDS ARE REQUESTED.	\$200,000.00
BONUSALLOC STRATEGIC TRANSPORTATION INVESTMENTS	4 PROJECTS	\$2,703,856.00
DIVISION STRATEGIC TRANSPORTATION INVESTMENTS	44 PROJECTS	\$49,507,011.00
REG/DIV STRATEGIC TRANSPORTATION INVESTMENTS	2 PROJECTS	\$1,550,000.00
REGIONAL STRATEGIC TRANSPORTATION INVESTMENTS	20 PROJECTS	(\$4,739,117.21)
STATEWIDE STRATEGIC TRANSPORTATION INVESTMENTS	16 PROJECTS	\$62,347,426.98
SW/REG STRATEGIC TRANSPORTATION INVESTMENTS	2 PROJECTS	\$850,000.00
STRATEGIC TRANSPORTATION INVESTMENTS	88 PROJECTS	\$112,219,176.77

MAY 4, 2023

**NCDOT MAY 2023 BOARD OF TRANSPORTATION AGENDA
APPROVAL OF FUNDS FOR SPECIFIC FEDERAL - AID PROJECTS**

TOWN/COUNTY PROJ. CATEGORY	PROJECT DESCRIPTION	ESTIMATED COST
Division 1		
CURRITUCK CO. R-2576 DIVISION	WBS 34470.1.TA1, FEDERAL NO. BRSTP-000S(494) MID-CURRITUCK BRIDGE FROM COINJOCK TO COROLLA. \$37,184,888.00 HAS PREVIOUSLY BEEN APPROVED FOR PRELIMINARY ENGINEERING. ADDITIONAL FUNDS ARE REQUESTED.	\$1,000,000.00 Cost \$800,000.00 Fed. \$200,000.00 State
MULTIPLE COUNTIES R-5781EC DIVISION	WBS 44911.3.22, FEDERAL NO. 0110040 ADA RAMPS (AMERICANS WITH DISABILITIES ACT) CURB RAMP UPGRADES AT VARIOUS LOCATIONS IN MARTIN, TYRRELL, AND WASHINGTON COUNTIES. \$250,000.00 HAS PREVIOUSLY BEEN APPROVED FOR CONSTRUCTION. ADDITIONAL FUNDS ARE REQUESTED. STATE MATCH USES DIVISION CONTRACT RESURFACING FUNDS.	\$30,000.00 Cost \$24,000.00 Fed. \$6,000.00 State

**NCDOT MAY 2023 BOARD OF TRANSPORTATION AGENDA
APPROVAL OF FUNDS FOR SPECIFIC FEDERAL - AID PROJECTS**

TOWN/COUNTY PROJ. CATEGORY	PROJECT DESCRIPTION	ESTIMATED COST
Division 2		
LENOIR CO. HS-2002K REGIONAL	WBS 49300.3.14, FEDERAL NO. 0011046 NC 11 AT SR 1716 (HARVEY ROUSE ROAD); NC 11 AT NC 118/SR 1091(GRIFTON-HUGO ROAD); AND NC 11 AT SR 1714 (CREEK ROAD). FUNDS ARE NEEDED FOR CONSTRUCTION TO CONVERT MEDIAN OPENINGS TO REDUCED CONFLICT INTERSECTIONS.	\$1,000,000.00 Cost \$900,000.00 Fed. \$100,000.00 State
DIVISIONWIDE CO. R-5782 DIVISION	WBS 44912.1.1, FEDERAL NO. 0220099 ADA RAMPS (AMERICANS WITH DISABILITIES ACT) CURB RAMP UPGRADES AT VARIOUS LOCATIONS DIVISIONWIDE. \$120,242.00 HAS PREVIOUSLY BEEN APPROVED FOR PRELIMINARY ENGINEERING. ADDITIONAL FUNDS ARE REQUESTED. STATE MATCH USES DIVISION CONTRACT RESURFACING FUNDS.	\$100,000.00 Cost \$80,000.00 Fed. \$20,000.00 State
PITT CO. R-5782BA DIVISION	WBS 44912.3.24, FEDERAL NO. 0220111 ADA RAMPS (AMERICANS WITH DISABILITIES ACT) CURB RAMP UPGRADES AT VARIOUS LOCATIONS IN PITT COUNTY. FUNDS ARE NEEDED FOR CONSTRUCTION. STATE MATCH USES DIVISION CONTRACT RESURFACING FUNDS.	\$450,000.00 Cost \$360,000.00 Fed. \$90,000.00 State
CARTERET CO. R-5782NB DIVISION	WBS 44912.3.17, FEDERAL NO. 0220101 ADA RAMPS (AMERICANS WITH DISABILITIES ACT) CURB RAMP UPGRADES AT VARIOUS LOCATIONS IN CARTERET COUNTY. \$542,000.00 HAS PREVIOUSLY BEEN APPROVED FOR CONSTRUCTION. ADDITIONAL FUNDS ARE REQUESTED. STATE MATCH USES DIVISION CONTRACT RESURFACING FUNDS.	\$10,000.00 Cost \$8,000.00 Fed. \$2,000.00 State
CARTERET CO. R-5968BB DIVISION	WBS 48797.3.5, FEDERAL NO. 0070243 14 BIO-RETENTION BUMP OUTS ALONG CEDAR STREET FROM ORANGE STREET TO MARSH STREET. \$1,000,000.00 HAS PREVIOUSLY BEEN APPROVED FOR CONSTRUCTION. ADDITIONAL FUNDS ARE REQUESTED.	\$150,000.00 Cost \$120,000.00 Fed. \$30,000.00 State

MAY 4, 2023

**NCDOT MAY 2023 BOARD OF TRANSPORTATION AGENDA
APPROVAL OF FUNDS FOR SPECIFIC FEDERAL - AID PROJECTS**

TOWN/COUNTY PROJ. CATEGORY	PROJECT DESCRIPTION	ESTIMATED COST
Division 2		
PITT CO. RX-2002A DIVISION	WBS 49302.1.2, FEDERAL NO. 4930212 HIGHWAY-RAIL GRADE CROSSING SAFETY PROJECT AT THE INTERSECTION OF SR 1726 (PORTERTOWN ROAD) AT CAROLINA COASTAL RAILWAY (CLNA) CROSSING #465 482M IN GREENVILLE. FUNDS ARE NEEDED FOR PRELIMINARY ENGINEERING.	\$40,000.00 Cost \$40,000.00 Fed.
PITT CO. RX-2002B DIVISION	WBS 49302.1.3, FEDERAL NO. 4930213 HIGHWAY-RAIL GRADE CROSSING SAFETY PROJECT AT THE INTERSECTION OF SR 1704 (FOURTEENTH STREET) AT CAROLINA COASTAL RAILWAY (CLNA) CROSSING #465 488D IN GREENVILLE. FUNDS ARE NEEDED FOR PRELIMINARY ENGINEERING.	\$40,000.00 Cost \$40,000.00 Fed.
PITT CO. RX-2002C DIVISION	WBS 49302.1.4, FEDERAL NO. 4930214 HIGHWAY-RAIL GRADE CROSSING SAFETY PROJECT AT THE INTERSECTION OF US 264 ALTERNATIVE (GREENVILLE BOULEVARD) AT CAROLINA COASTAL RAILWAY (CLNA) CROSSING #465 489K IN GREENVILLE. FUNDS ARE NEEDED FOR PRELIMINARY ENGINEERING.	\$40,000.00 Cost \$40,000.00 Fed.
LENOIR CO. RX-2002D DIVISION	WBS 49302.1.5, FEDERAL NO. 4930215 HIGHWAY-RAIL GRADE CROSSING SAFETY PROJECT AT THE INTERSECTION OF LINCOLN STREET AT NORFOLK SOUTHERN RAILWAY (NSR) CROSSING #722 776G IN KINSTON. FUNDS ARE NEEDED FOR PRELIMINARY ENGINEERING.	\$50,000.00 Cost \$50,000.00 Fed.
PITT CO. RX-2002E DIVISION	WBS 49302.1.6, FEDERAL NO. 4930216 HIGHWAY-RAIL GRADE CROSSING SAFETY PROJECT AT THE INTERSECTION OF SR 1530 (AIRPORT ROAD) AT CSX CROSSING #641 860P IN GREENVILLE. FUNDS ARE NEEDED FOR PRELIMINARY ENGINEERING.	\$70,000.00 Cost \$70,000.00 Fed.

MAY 4, 2023

**NCDOT MAY 2023 BOARD OF TRANSPORTATION AGENDA
APPROVAL OF FUNDS FOR SPECIFIC FEDERAL - AID PROJECTS**

TOWN/COUNTY PROJ. CATEGORY	PROJECT DESCRIPTION	ESTIMATED COST
Division 2		
PITT CO. U-2817 DIVISION	WBS 34868.2.2, FEDERAL NO. STP-1700(015) SR 1700 (EVANS STREET/OLD TAR ROAD) FROM SR 1711 (WORTHINGTON ROAD) IN WINTERVILLE TO US 264 ALTERNATE (GREENVILLE BOULEVARD) INGREENVILLE. \$5,000,000.00 HAS PREVIOUSLY BEEN APPROVED FOR RIGHT OF WAY. ADDITIONAL FUNDS ARE REQUESTED BASED ON THE LATEST ESTIMATE FOR ROW COSTS.	\$48,700,000.00 Cost \$38,960,000.00 Fed. \$9,740,000.00 State
BEAUFORT CO. W-5702I REGIONAL	WBS 44848.3.9, FEDERAL NO. HSIP-0264(065) US 264 AT NC 32. FUNDS ARE NEEDED FOR CONSTRUCTION FOR ROUNDABOUT.	\$1,800,000.00 Cost \$1,620,000.00 Fed. \$180,000.00 State
PITT CO. W-5702M DIVISION	WBS 44848.1.13, FEDERAL NO. HSIP-1711(006) SR 1711 (WORTHINGTON ROAD) AT SR 1709 (COREY ROAD). \$380,000.00 HAS PREVIOUSLY BEEN APPROVED FOR PRELIMINARY ENGINEERING. ADDITIONAL FUNDS ARE REQUESTED.	\$40,000.00 Cost \$36,000.00 Fed. \$4,000.00 State
BEAUFORT CO. W-5702R REGIONAL	WBS 44848.3.18, FEDERAL NO. HSIP-0264(071) US 264 FROM APPROXIMATELY 800 FEET EAST OF SR 1311(ASBURY CHURCH ROAD) TO APPROXIMATELY 1600 FEET WEST OF SR 1327 (NECK ROAD) NEAR SR 1522 (LIZZARD SLIP ROAD). FUNDS ARE NEEDED FOR CONSTRUCTION TO CONSTRUCT A SUPERSTREET.	\$2,750,000.00 Cost \$2,475,000.00 Fed. \$275,000.00 State

**NCDOT MAY 2023 BOARD OF TRANSPORTATION AGENDA
APPROVAL OF FUNDS FOR SPECIFIC FEDERAL - AID PROJECTS**

TOWN/COUNTY PROJ. CATEGORY	PROJECT DESCRIPTION	ESTIMATED COST
Division 3		
DUPLIN CO. B-5632 DIVISION	WBS 45587.3.1, FEDERAL NO. BRZ-1828(001) REPLACE BRIDGE #300187 OVER BACK SWAMP ON SR 1828. FUNDS ARE NEEDED FOR CONSTRUCTION. THIS IS A TWO-YEAR CASH FLOW PROJECT WITH FEDERAL FUNDS OF \$691,200.00 IN FY23 AND \$3,148,800.00 IN FY24, AND STATE MATCH OF \$172,800.00 IN FY23 AND \$787,200.00 IN FY24.	\$4,800,000.00 Cost \$3,840,000.00 Fed. \$960,000.00 State
NEW HANOVER CO. BL-0059 EXEMPT	WBS 50399.1.2, FEDERAL NO. 0316002 FORT FISHER BOULEVARD, K AVENUE, AND NORTH 3RD STREET INTERSECTION IMPROVEMENTS INCLUDING ADA CROSSWALKS, PEDESTRIAN ACTUATED PUSH BUTTONS, AND SIDEWALK CONNECTIONS IN KURE BEACH. FUNDS ARE NEEDED FOR PRELIMINARY ENGINEERING. THIS WBS IS FUNDED WITH 100% COVID RELIEF FUNDS.	\$110,000.00 Cost \$110,000.00 Fed.
PENDER CO. HS-2003F STATEWIDE	WBS 49303.1.7, FEDERAL NO. 0017(196) US 17 AND NC 210. \$10,000.00 HAS PREVIOUSLY BEEN APPROVED FOR PRELIMINARY ENGINEERING. ADDITIONAL FUNDS ARE REQUESTED.	\$5,000.00 Cost \$4,500.00 Fed. \$500.00 State
NEW HANOVER/ PENDER COUNTIES I-6039 STATEWIDE	WBS 47988.3.1, FEDERAL NO. 4798831 I-40 IN NEW HANOVER/PENDER COUNTIES FROM MILEMARKER 420 TO NC 210 (MILEMARKER 408). FUNDS ARE NEEDED FOR CONSTRUCTION BASED ON THE ESTIMATE FROM THE 12-MONTH TENTATIVE LETTING LIST. THIS IS A THREE-YEAR CASH FLOW PROJECT WITH FEDERAL FUNDS OF \$1,014,400.00 IN FY23, \$7,616,800.00 IN FY24, AND \$1,928,800.00 IN FY25, AND STATE MATCH OF \$253,600,00 IN FY23, \$1,904,200.00 IN FY24, AND \$482,200.00 IN FY25.	\$13,200,000.00 Cost \$10,560,000.00 Fed. \$2,640,000.00 State

**NCDOT MAY 2023 BOARD OF TRANSPORTATION AGENDA
APPROVAL OF FUNDS FOR SPECIFIC FEDERAL - AID PROJECTS**

TOWN/COUNTY PROJ. CATEGORY	PROJECT DESCRIPTION	ESTIMATED COST
Division 3		
NEW HANOVER CO. W-5803A REGIONAL	WBS 48948.3.2, FEDERAL NO. 0074230 US 74 (EASTWOOD ROAD) AT US 17 (MILITARY CUTOFF ROAD) AND US 74 (EASTWOOD ROAD) AT CAVALIER DRIVE. FUNDS ARE NEEDED FOR CONSTRUCTION TO UPGRADE TRAFFIC AND PEDESTRIAN SIGNALS AND REVISE MEDIAN ISLANDS.	\$170,000.00 Cost \$153,000.00 Fed. \$17,000.00 State
MULTIPLE COUNTIES W-5803B STATEWIDE	WBS 48948.3.3, FEDERAL NO. 0017187 US 17 BETWEEN THE NEW HANOVER/PENDER COUNTY LINE AND MILE POST 19.30 IN ONSLOW COUNTY. \$425,000.00 HAS PREVIOUSLY BEEN APPROVED FOR CONSTRUCTION. ADDITIONAL FUNDS ARE REQUESTED.	\$25,000.00 Cost \$22,500.00 Fed. \$2,500.00 State

**NCDOT MAY 2023 BOARD OF TRANSPORTATION AGENDA
APPROVAL OF FUNDS FOR SPECIFIC FEDERAL - AID PROJECTS**

TOWN/COUNTY PROJ. CATEGORY	PROJECT DESCRIPTION	ESTIMATED COST
Division 4		
EDGECOMBE CO. B-4933 REGIONAL	WBS 40136.1.1, FEDERAL NO. BRSTP-0033(6) REPLACE BRIDGE #320080 OVER THE TAR RIVER AND REPLACE BRIDGE #320049 OVER THE TAR RIVER OVERFLOW ON NC 33 IN TARBORO. \$613,818.00 HAS PREVIOUSLY BEEN APPROVED FOR PRELIMINARY ENGINEERING. ADDITIONAL FUNDS ARE REQUESTED.	\$100,000.00 Cost \$80,000.00 Fed. \$20,000.00 State
HALIFAX CO. HS-2004T REGIONAL	WBS 49306.1.21, FEDERAL NO. 4930611 US 158 FROM BETWEEN THE EASTERN LITTLETON TOWN LIMITS AND 0.15 MILE WEST OF SR 1432 (EVERETTS SCHOOL ROAD). FUNDS ARE NEEDED FOR PRELIMINARY ENGINEERING.	\$5,000.00 Cost \$4,500.00 Fed. \$500.00 State
WILSON/ NASH COUNTIES HS-2004U REGIONAL	WBS 49306.1.22, FEDERAL NO. 4930612 NC 58 BETWEEN THE NORTHERN STANTONSBURG TOWN LIMITS AND 0.275 MILE NORTH OF SR 1622 (EVANSDALE ROAD) IN WILSON COUNTY; NC 58 BETWEEN 0.191 MILE SOUTH OF SR 1314 (THOMPSON CHAPEL CHURCH ROAD) IN WILSON COUNTY AND THE SOUTHERN NASHVILLE TOWN LIMITS IN NASH COUNTY; AND NC 58 BETWEEN 0.249 MILE SOUTH OF SR 1004 (TAYLOR'S STORE ROAD) AND THE SOUTHERN CASTALIA TOWN LIMIT IN NASH COUNTY. FUNDS ARE NEEDED FOR PRELIMINARY ENGINEERING.	\$5,000.00 Cost \$4,500.00 Fed. \$500.00 State

**NCDOT MAY 2023 BOARD OF TRANSPORTATION AGENDA
APPROVAL OF FUNDS FOR SPECIFIC FEDERAL - AID PROJECTS**

TOWN/COUNTY PROJ. CATEGORY	PROJECT DESCRIPTION	ESTIMATED COST
Division 4		
MULTIPLE COUNTIES HS-2004V REGIONAL	WBS 49306.1.23, FEDERAL NO. 4930613 NC 111 BETWEEN THE WAYNE/DUPLIN COUNTY LINE AND SR 1727 (DOLLARD TOWN ROAD); NC 111 BETWEEN THE US 70 BYPASS OVERPASS AND NC 222; NC 222/NC 111 BETWEEN THE FREMONT TOWN LIMITS 0.05 MILE EAST OF GREEN STREET AND SR 1525 (STAN-RAY ROAD) NEAR EUREKA; NC 222/NC 111 BETWEEN SR 1513 (RED HILLROAD) NEAR EUREKA AND THE STANTONSBURG TOWN LIMITS AT THE BRIDGE OVER CONTENTNEA CREEK; NC 222/NC111 BETWEEN NC 222 IN WILSON COUNTY AND SR 1344 (SARA LEE ROAD) IN EDGEcombe COUNTY AND NC 111 BETWEEN PRINCEVILLE AND THE EDGEcombe/MARTIN COUNTY LINE. FUNDS ARE NEEDED FOR PRELIMINARY ENGINEERING.	\$1,000.00 Cost \$900.00 Fed. \$100.00 State
JOHNSTON CO. HS-2004W STATEWIDE	WBS 49306.1.24, FEDERAL NO. 4930614 US 70 AT US 70A/SR 2532 (W. EDWARDS STREET) AND AT SR 2314 (PONDFIELD ROAD). FUNDS ARE NEEDED FOR PRELIMINARY ENGINEERING.	\$100,000.00 Cost \$90,000.00 Fed. \$10,000.00 State
MULTIPLE COUNTIES HS-2004X REGIONAL	WBS 49306.1.25, FEDERAL NO. 4930615 NC 43 BETWEEN 0.5 MILE NORTH OF SR 1425 (CASTALIA ROAD) IN NASH COUNTY AND NC 561 IN HALIFAX COUNTY. FUNDS ARE NEEDED FOR PRELIMINARY ENGINEERING.	\$1,000.00 Cost \$900.00 Fed. \$100.00 State

**NCDOT MAY 2023 BOARD OF TRANSPORTATION AGENDA
APPROVAL OF FUNDS FOR SPECIFIC FEDERAL - AID PROJECTS**

TOWN/COUNTY PROJ. CATEGORY	PROJECT DESCRIPTION	ESTIMATED COST
Division 4		
JOHNSTON CO. R-5784EA DIVISION	WBS 44914.3.21, FEDERAL NO. 0406011 ADA RAMPS (AMERICANS WITH DISABILITIES ACT) CURB RAMP UPGRADES AT VARIOUS LOCATIONS IN JOHNSTON COUNTY. \$157,800.00 HAS PREVIOUSLY BEEN APPROVED FOR CONSTRUCTION. ADDITIONAL FUNDS ARE NEEDED TO COVER EXPENDITURES THAT HAVE OR WILL EXCEED THE PREVIOUSLY AUTHORIZED BUDGET. STATE MATCH USES DIVISION CONTRACT RESURFACING FUNDS.	\$75,000.00 Cost \$60,000.00 Fed. \$15,000.00 State
EDGECOMBE CO. R-5784ED DIVISION	WBS 44914.3.24, FEDERAL NO. 44914.3 ADA RAMPS (AMERICANS WITH DISABILITIES ACT) CURB RAMP UPGRADES AT VARIOUS LOCATIONS IN ROCKY MOUNT. FUNDS ARE NEEDED FOR CONSTRUCTION. STATE MATCH USES DIVISION CONTRACT RESURFACING FUNDS.	\$950,000.00 Cost \$760,000.00 Fed. \$190,000.00 State
NASH CO. R-5784EE DIVISION	WBS 44914.3.25, FEDERAL NO. 4491401 ADA RAMPS (AMERICANS WITH DISABILITIES ACT) CURB RAMP UPGRADES AT VARIOUS LOCATIONS IN MIDDLESEX, NASHVILLE, AND SPRING HOPE. FUNDS ARE NEEDED FOR CONSTRUCTION. STATE MATCH USES DIVISION CONTRACT RESURFACING FUNDS.	\$450,000.00 Cost \$360,000.00 Fed. \$90,000.00 State
JOHNSTON CO. R-5784EF DIVISION	WBS 44914.3.26, FEDERAL NO. 4491402 ADA RAMPS (AMERICANS WITH DISABILITIES ACT) CURB RAMP UPGRADES AT VARIOUS LOCATIONS IN BENSON AND SMITHFIELD. FUNDS ARE NEEDED FOR CONSTRUCTION. STATE MATCH USES DIVISION CONTRACT RESURFACING FUNDS.	\$350,000.00 Cost \$280,000.00 Fed. \$70,000.00 State
HALIFAX CO. R-5784EG DIVISION	WBS 44914.3.27, FEDERAL NO. 4491404 ADA RAMPS (AMERICANS WITH DISABILITIES ACT) CURB RAMP UPGRADES AT VARIOUS LOCATIONS IN WELDON. FUNDS ARE NEEDED FOR CONSTRUCTION. STATE MATCH USES DIVISION CONTRACT RESURFACING FUNDS.	\$250,000.00 Cost \$200,000.00 Fed. \$50,000.00 State

**NCDOT MAY 2023 BOARD OF TRANSPORTATION AGENDA
APPROVAL OF FUNDS FOR SPECIFIC FEDERAL - AID PROJECTS**

TOWN/COUNTY PROJ. CATEGORY	PROJECT DESCRIPTION	ESTIMATED COST	
Division 4			
JOHNSTON CO. RX-2004D DIVISION	WBS 49308.1.5, FEDERAL NO. 4930801	\$55,000.00	Cost
	HIGHWAY-RAIL GRADE SAFETY PROJECT AT THE INTERSECTION OF PARRISH DRIVE AT CSX CROSSING #629 739C IN BENSON. FUNDS ARE NEEDED FOR PRELIMINARY ENGINEERING.	\$55,000.00	Fed.
WILSON CO. RX-2004E DIVISION	WBS 49308.1.6, FEDERAL NO. 4930802	\$55,000.00	Cost
	HIGHWAY-RAIL GRADE SAFETY PROJECT AT THE INTERSECTION OF SR 1329 (VAN SLYKE ROAD) AT CSX CROSSING #629 843W NEAR WILSON. FUNDS ARE NEEDED FOR PRELIMINARY ENGINEERING.	\$55,000.00	Fed.
WAYNE CO. RX-2004F DIVISION	WBS 49308.1.7, FEDERAL NO. 4930803	\$55,000.00	Cost
	HIGHWAY-RAIL GRADE SAFETY PROJECT AT THE INTERSECTION OF BAIN STREET AT NORFOLK SOUTHERN RAILWAY CROSSING #722 874X IN GOLDSBORO. FUNDS ARE NEEDED FOR PRELIMINARY ENGINEERING.	\$55,000.00	Fed.
JOHNSTON CO. RX-2004G DIVISION	WBS 49308.1.8, FEDERAL NO. 4930804	\$55,000.00	Cost
	HIGHWAY-RAIL GRADE SAFETY PROJECT AT THE INTERSECTION OF SR 2130 (MAIN STREET) AT CSX CROSSING #629 943B IN MICRO. FUNDS ARE NEEDED FOR PRELIMINARY ENGINEERING.	\$55,000.00	Fed.
JOHNSTON CO. RX-2004J DIVISION	WBS 49308.1.11, FEDERAL NO. 4930807	\$55,000.00	Cost
	HIGHWAY-RAIL GRADE SAFETY PROJECT AT THE INTERSECTION OF SR 2339 (BAGLEY ROAD) AT CSX CROSSING #629 939L NEAR KENLY. FUNDS ARE NEEDED FOR PRELIMINARY ENGINEERING.	\$55,000.00	Fed.
JOHNSTON CO. RX-2004K DIVISION	WBS 49308.1.12, FEDERAL NO. 4930808	\$55,000.00	Cost
	HIGHWAY-RAIL GRADE SAFETY PROJECT AT THE INTERSECTION OF LEE STREET AT CSX CROSSING #629 964U IN SMITHFIELD. FUNDS ARE NEEDED FOR PRELIMINARY ENGINEERING.	\$55,000.00	Fed.

MAY 4, 2023

**NCDOT MAY 2023 BOARD OF TRANSPORTATION AGENDA
APPROVAL OF FUNDS FOR SPECIFIC FEDERAL - AID PROJECTS**

TOWN/COUNTY PROJ. CATEGORY	PROJECT DESCRIPTION	ESTIMATED COST
Division 4		
JOHNSTON CO. RX-2004L DIVISION	WBS 49308.1.13, FEDERAL NO. 4930811 HIGHWAY-RAIL GRADE CROSSING SAFETY PROJECT AT THE INTERSECTION OF SR 2500 (WALLPAT ROAD) AT CSX CROSSING #629 966H IN SMITHFIELD. FUNDS ARE NEEDED FOR PRELIMINARY ENGINEERING.	\$55,000.00 Cost \$55,000.00 Fed.
WAYNE CO. RX-2004M DIVISION	WBS 49308.1.14, FEDERAL NO. 4930814 HIGHWAY-RAIL GRADE CROSSING SAFETY PROJECT AT THE INTERSECTION OF JEFFERSON STREET AT NORFOLK SOUTHERN RAILWAY (NSR) CROSSING #722 868U IN GOLDSBORO. FUNDS ARE NEEDED FOR PRELIMINARY ENGINEERING.	\$55,000.00 Cost \$55,000.00 Fed.
WAYNE CO. W-5704K DIVISION	WBS 44850.1.11, FEDERAL NO. HSIP-1927(006) SR 1927 (GENOA ROAD) AT CRESCENT DRIVE NEAR GENOA. \$93,000.00 HAS PREVIOUSLY BEEN APPROVED FOR PRELIMINARY ENGINEERING. ADDITIONAL FUNDS ARE NEEDED TO COVER EXPENDITURES THAT HAVE OR WILL EXCEED THE PREVIOUSLY AUTHORIZED BUDGET.	\$20,000.00 Cost \$18,000.00 Fed. \$2,000.00 State
JOHNSTON CO. W-5704S REGIONAL	WBS 44850.1.19, FEDERAL NO. HSIP-0042(077) NC 42 AT NC 96. \$475,000.00 HAS PREVIOUSLY BEEN APPROVED FOR PRELIMINARY ENGINEERING. ADDITIONAL FUNDS ARE NEEDED TO COVER EXPENDITURES THAT HAVE OR WILL EXCEED THE PREVIOUSLY AUTHORIZED BUDGET.	\$25,000.00 Cost \$22,500.00 Fed. \$2,500.00 State

**NCDOT MAY 2023 BOARD OF TRANSPORTATION AGENDA
APPROVAL OF FUNDS FOR SPECIFIC FEDERAL - AID PROJECTS**

TOWN/COUNTY PROJ. CATEGORY	PROJECT DESCRIPTION	ESTIMATED COST
Division 5		
MULTIPLE COUNTIES HO-0010A STATEWIDE	WBS 50631.4.1, FEDERAL NO. 5063141 STATEWIDE -TRAFFIC OPERATIONS. FUNDS ARE NEEDED FOR PROGRAM IMPLEMENTATION FOR OPERATION ACTIVITIES THAT INCLUDE TRAFFIC MANAGEMENT CENTERS, TRAVELER INFORMATION, ITS, AND TRAFFIC INCIDENT AND EVENT MANAGEMENT IN THE TRIANGLE AND METROLINA AREAS. STATE MATCH USES STATE HIGHWAY TRUST FUNDS.	\$5,245,275.00 Cost \$4,196,220.00 Fed. \$1,049,055.00 State
WAKE CO. I-5701 STATEWIDE	WBS 50119.1.1, FEDERAL NO. NHPP-040-4(156)298 I-40/US 64 FROM I-440/US 1/US 64 TO SR 1370 (LAKE WHEELER ROAD) IN RALEIGH. \$2,084,000.00 HAS PREVIOUSLY BEEN APPROVED FOR PRELIMINARY ENGINEERING. ADDITIONAL FUNDS ARE REQUESTED.	\$100,000.00 Cost \$80,000.00 Fed. \$20,000.00 State
WAKE CO. I-5703 STATEWIDE	WBS 50120.1.1, FEDERAL NO. NHPP-040-4(157)294 I-40 AND I-440/US 1/US 64 INTERSECTION. \$4,301,877.00 HAS PREVIOUSLY BEEN APPROVED FOR PRELIMINARY ENGINEERING. ADDITIONAL FUNDS ARE REQUESTED.	\$250,000.00 Cost \$200,000.00 Fed. \$50,000.00 State
WAKE CO. R-5785J DIVISION	WBS 44915.3.16, FEDERAL NO. 0505115 ADA RAMPS (AMERICANS WITH DISABILITIES ACT) CURB RAMP UPGRADES AT VARIOUS LOCATIONS IN KNIGHTDALE, HOLLY SPRINGS, AND ZEBULON. FUNDS ARE NEEDED FOR CONSTRUCTION. STATE MATCH USES DIVISION CONTRACT RESURFACING FUNDS.	\$2,254,000.00 Cost \$1,803,200.00 Fed. \$450,800.00 State
WAKE CO. U-5530OB DIVISION	WBS 44111.3.16, FEDERAL NO. STPDA-0505(72) SAFE ROUTES TO SCHOOL. PEDESTRIAN AND BICYCLE IMPROVEMENTS ON STREETS ADJACENT TO LEESVILLE ROAD SCHOOLS COMPLEX IN RALEIGH. \$436,480.00 HAS PREVIOUSLY BEEN APPROVED FOR CONSTRUCTION. ADDITIONAL FUNDS ARE REQUESTED.	\$278,375.00 Cost \$222,700.00 Fed. \$55,675.00 Local

MAY 4, 2023

**NCDOT MAY 2023 BOARD OF TRANSPORTATION AGENDA
APPROVAL OF FUNDS FOR SPECIFIC FEDERAL - AID PROJECTS**

TOWN/COUNTY PROJ. CATEGORY	PROJECT DESCRIPTION	ESTIMATED COST
Division 5		
WAKE CO. U-5751 REGIONAL	WBS 54033.1.FR1, FEDERAL NO. NHP-0401(267) US 401 FROM NC 55/NC 42 IN FUQUAUAY-VARINA. \$2,907,000.00 HAS PREVIOUSLY BEEN APPROVED FOR PRELIMINARY ENGINEERING. ADDITIONAL FUNDS ARE REQUESTED.	\$250,000.00 Cost \$200,000.00 Fed. \$50,000.00 State
WAKE CO. W-5601GC REGIONAL	WBS 50138.1.186, FEDERAL NO. HSIP-0042(068) NC 42 AT SR 1173 (BAREFOOT ROAD). \$202,500.00 HAS PREVIOUSLY BEEN APPROVED FOR PRELIMINARY ENGINEERING. ADDITIONAL FUNDS ARE REQUESTED.	\$15,000.00 Cost \$13,500.00 Fed. \$1,500.00 State

**NCDOT MAY 2023 BOARD OF TRANSPORTATION AGENDA
APPROVAL OF FUNDS FOR SPECIFIC FEDERAL - AID PROJECTS**

TOWN/COUNTY PROJ. CATEGORY	PROJECT DESCRIPTION	ESTIMATED COST
Division 6		
HARNETT CO. HB-0008 DIVISION	WBS 50348.1.1, FEDERAL NO. 1214(009) REPLACE BRIDGE #420034 OVER UPPER LITTLE RIVER ON SR 1214. \$150,000.00 HAS PREVIOUSLY BEEN APPROVED FOR PRELIMINARY ENGINEERING. ADDITIONAL FUNDS ARE REQUESTED.	\$50,000.00 Cost \$40,000.00 Fed. \$10,000.00 State
COLUMBUS CO. HB-0009 DIVISION	WBS 50349.1.1, FEDERAL NO. 1800(007) REPLACE BRIDGE #230250 OVER RICE FIELD BRANCH ON SR 1800. \$150,000.00 HAS PREVIOUSLY BEEN APPROVED FOR PRELIMINARY ENGINEERING. ADDITIONAL FUNDS ARE REQUESTED.	\$50,000.00 Cost \$40,000.00 Fed. \$10,000.00 State
CUMBERLAND CO. HB-0010 DIVISION	WBS 50350.1.1, FEDERAL NO. 1716(005) REPLACE BRIDGE #250091 OVER WADE CANAL ON SR 1716. \$150,000.00 HAS PREVIOUSLY BEEN APPROVED FOR PRELIMINARY ENGINEERING. ADDITIONAL FUNDS ARE REQUESTED.	\$50,000.00 Cost \$40,000.00 Fed. \$10,000.00 State
CUMBERLAND CO. HS-2006P DIVISION	WBS 49312.1.20, FEDERAL NO. 3950(001) SR 3950 (RAMSEY STREET) AT RAILROAD BRIDGE #250216 LOCATED BETWEEN DRAKE STREET AND WALL STREET. \$80,000.00 HAS PREVIOUSLY BEEN APPROVED FOR PRELIMINARY ENGINEERING. ADDITIONAL FUNDS ARE REQUESTED.	\$55,000.00 Cost \$49,500.00 Fed. \$5,500.00 State
HARNETT CO. HS-2006Q DIVISION	WBS 49312.1.21, FEDERAL NO. 1532(006) SR 1532 (LANGDON ROAD) AT BRIDGE #420015. \$150,000.00 HAS PREVIOUSLY BEEN APPROVED FOR PRELIMINARY ENGINEERING. ADDITIONAL FUNDS ARE REQUESTED.	\$50,000.00 Cost \$40,000.00 Fed. \$10,000.00 State
HARNETT CO. HS-2006Q DIVISION	WBS 49312.2.21, FEDERAL NO. 1532006 SR 1532 (LANGDON ROAD) AT BRIDGE #420015. FUNDS ARE NEEDED FOR FULL RIGHT OF WAY.	\$40,000.00 Cost \$36,000.00 Fed. \$4,000.00 State

**NCDOT MAY 2023 BOARD OF TRANSPORTATION AGENDA
APPROVAL OF FUNDS FOR SPECIFIC FEDERAL - AID PROJECTS**

TOWN/COUNTY PROJ. CATEGORY	PROJECT DESCRIPTION	ESTIMATED COST
Division 6		
HARNETT CO. RX-2006C DIVISION	WBS 49314.1.4, FEDERAL NO. 4931401 HIGHWAY-RAIL GRADE SAFETY PROJECT AT THE INTERSECTION OF HARNETT STREET AT CSX CROSSING #629 751J IN DUNN. FUNDS ARE NEEDED FOR PRELIMINARY ENGINEERING.	\$55,000.00 Cost \$55,000.00 Fed.
HARNETT CO. RX-2006D DIVISION	WBS 49314.1.5, FEDERAL NO. 4931402 HIGHWAY-RAIL GRADE SAFETY PROJECT AT THE INTERSECTION OF EDGERTON STREET AT CSX CROSSING #629 752R IN DUNN. FUNDS ARE NEEDED FOR PRELIMINARY ENGINEERING.	\$55,000.00 Cost \$55,000.00 Fed.
ROBESON CO. RX-2006E DIVISION	WBS 49314.1.6, FEDERAL NO. 4931416 HIGHWAY-RAIL GRADE CROSSING SAFETY PROJECT AT THE INTERSECTION OF NC 41 (MARTIN LUTHER KING JR DRIVE) AT CSX CROSSING #631 029P IN LUMBERTON. FUNDS ARE NEEDED FOR PRELIMINARY ENGINEERING.	\$55,000.00 Cost \$55,000.00 Fed.
HARNETT CO. RX-2006F DIVISION	WBS 49314.1.7, FEDERAL NO. 4931403 HIGHWAY-RAIL GRADE SAFETY PROJECT AT THE INTERSECTION OF US 401 (MAIN STREET) AT RALEIGH & FAYETTEVILLE RAILROAD (RFCC) CROSSING #465 860F IN LILLINGTON. FUNDS ARE NEEDED FOR PRELIMINARY ENGINEERING.	\$40,000.00 Cost \$40,000.00 Fed.
ROBESON CO. RX-2006G DIVISION	WBS 49314.1.8, FEDERAL NO. 4931404 HIGHWAY-RAIL GRADE SAFETY PROJECT AT THE INTERSECTION OF SR 1748 (CRENSHAW ROAD) AT CSX CROSSING #629 581S NEAR REX. FUNDS ARE NEEDED FOR PRELIMINARY ENGINEERING.	\$55,000.00 Cost \$55,000.00 Fed.

**NCDOT MAY 2023 BOARD OF TRANSPORTATION AGENDA
APPROVAL OF FUNDS FOR SPECIFIC FEDERAL - AID PROJECTS**

TOWN/COUNTY PROJ. CATEGORY	PROJECT DESCRIPTION	ESTIMATED COST
Division 7		
GUILFORD CO. EB-5874 DIVISION	WBS 47330.1.1, FEDERAL NO. 0068016 NC 68 (EASTCHESTER DRIVE) FROM JOHNSON STREET TO SR 1278 (NORTH COLLEGE DRIVE) IN HIGH POINT. FUNDS ARE NEEDED FOR PRELIMINARY ENGINEERING.	\$10,000.00 Cost \$8,000.00 Fed. \$2,000.00 Local
GUILFORD CO. HL-0046 DIVISION	WBS 49897.2.1, FEDERAL NO. 4240003 SR 4240 (EAST GATE CITY BOULEVARD) FROM WILLOW ROAD TO FLORIDA STREET IN GREENSBORO. FUNDS ARE NEEDED FOR FULL RIGHT OF WAY.	\$150,000.00 Cost \$120,000.00 Fed. \$30,000.00 Local
MULTIPLE COUNTIES R-5787K DIVISION	WBS 44917.1.14, FEDERAL NO. 4491714 ADA RAMPS (AMERICANS WITH DISABILITIES ACT) CURB RAMP UPGRADES AT VARIOUS LOCATIONS IN ALAMANCE AND ORANGE COUNTIES. FUNDS ARE NEEDED FOR PRELIMINARY ENGINEERING. STATE MATCH USES DIVISION CONTRACT RESURFACING FUNDS.	\$100,000.00 Cost \$80,000.00 Fed. \$20,000.00 State
GUILFORD CO. R-5787L DIVISION	WBS 44917.1.15, FEDERAL NO. 4491715 ADA RAMPS (AMERICANS WITH DISABILITIES ACT) CURB RAMP UPGRADES AT VARIOUS LOCATIONS IN GUILFORD COUNTY. FUNDS ARE NEEDED FOR PRELIMINARY ENGINEERING. STATE MATCH USES DIVISION CONTRACT RESURFACING FUNDS.	\$100,000.00 Cost \$80,000.00 Fed. \$20,000.00 State
GUILFORD CO. Y-4807B DIVISION	WBS 40325.3.59, FEDERAL NO. STPRR-0708(41) PROPOSED HIGHWAY-RAIL CROSSING CLOSURE AT THE INTERSECTION OF PINE STREET AND NORFOLK SOUTHERN (NSR) CROSSING #722 957L IN GREENSBORO. FUNDS ARE NEEDED FOR CONSTRUCTION FOR RAIL CROSSING CLOSURE.	\$5,000,000.00 Cost \$4,500,000.00 Fed. \$500,000.00 State

**NCDOT MAY 2023 BOARD OF TRANSPORTATION AGENDA
APPROVAL OF FUNDS FOR SPECIFIC FEDERAL - AID PROJECTS**

TOWN/COUNTY PROJ. CATEGORY	PROJECT DESCRIPTION	ESTIMATED COST
Division 8		
CHATHAM CO. BL-0070 DIVISION	WBS 50557.3.1, FEDERAL NO. 0505114 NORTH SIDE OF GOVERNORS DRIVE TO THE EXISTING SIDEWALK ON MOUNT CARMEL CHURCH DRIVE; INTERSECTION OF MORNING DRIVE AND VILLAGE PARK DRIVE AND US 15/US 501 AND OLD LYSTRA ROAD IN CHATHAM COUNTY. FUNDS ARE NEEDED FOR CONSTRUCTION FOR SIDEWALK AND PEDESTRIAN IMPROVEMENTS. THE DEPARTMENT WILL PROVIDE HIGH IMPACT/LOW-COST STATE FUNDS FOR 10% OF THE NON-FEDERAL MATCH.	\$175,000.00 Cost \$140,000.00 Fed. \$17,500.00 State \$17,500.00 Local
LEE CO. EB-5870 DIVISION	WBS 47326.3.1, FEDERAL NO. TAP-1579(001) SR 1579 (SOUTH MAIN STREET) FROM SR 1531 (MANSFIELD DRIVE) TO THE END OF THE EXISTING SIDEWALK IN BROADWAY. FUNDS ARE NEEDED FOR CONSTRUCTION FOR SIDEWALK AND PEDESTRIAN IMPROVEMENTS.	\$195,000.00 Cost \$156,000.00 Fed. \$39,000.00 Local
CHATHAM CO. R-5788GC DIVISION	WBS 44918.3.18, FEDERAL NO. 0801037 ADA RAMPS (AMERICANS WITH DISABILITES ACT) CURB RAMP UPGRADES AT VARIOUS LOCATIONS IN CHATHAM COUNTY. \$215,000.00 HAS PREVIOUSLY BEEN APPROVED FOR CONSTRUCTION. ADDITIONAL FUNDS ARE REQUESTED. STATE MATCH USES DIVISION CONTRACT RESURFACING FUNDS.	\$65,000.00 Cost \$52,000.00 Fed. \$13,000.00 State
MULTIPLE COUNTIES R-5788GD DIVISION	WBS 44918.3.19, FEDERAL NO. 0801038 ADA RAMPS (AMERICANS WITH DISABILITIES ACT) CURB RAMP UPGRADES AT VARIOUS LOCATIONS IN CHATHAM AND RANDOLPH COUNTIES. \$157,000.00 HAS PREVIOUSLY BEEN APPROVED FOR CONSTRUCTION. ADDITIONAL FUNDS ARE REQUESTED. STATE MATCH USES DIVISION CONTRACT RESURFACING FUNDS.	\$5,000.00 Cost \$4,000.00 Fed. \$1,000.00 State

MAY 4, 2023

**NCDOT MAY 2023 BOARD OF TRANSPORTATION AGENDA
APPROVAL OF FUNDS FOR SPECIFIC FEDERAL - AID PROJECTS**

TOWN/COUNTY PROJ. CATEGORY	PROJECT DESCRIPTION	ESTIMATED COST
Division 8		
MOORE CO. RX-2008B DIVISION	WBS 49320.1.3, FEDERAL NO. 4932013 HIGHWAY-RAIL GRADE CROSSING SAFETY PROJECT AT THE INTERSECTION OF SOUTH STREET AT ABERDEEN CAROLINA AND WESTERN RAILWAY COMPANY (ACWR) CROSSING #722 526U IN ABERDEEN. FUNDS ARE NEEDED FOR PRELIMINARY ENGINEERING.	\$56,000.00 Cost \$56,000.00 Fed.
RICHMOND CO. RX-2008C DIVISION	WBS 49320.1.4, FEDERAL NO. 4932014 HIGHWAY-RAIL GRADE CROSSING SAFETY PROJECT AT THE INTERSECTION OF SR 1925 (BILTMORE DRIVE) AT CSX CROSSING #630 856U NEAR ROCKINGHAM. FUNDS ARE NEEDED FOR PRELIMINARY ENGINEERING.	\$55,000.00 Cost \$55,000.00 Fed.
HOKE CO. RX-2008D DIVISION	WBS 49320.1.5, FEDERAL NO. 4932015 HIGHWAY-RAIL GRADE CROSSING SAFETY PROJECT AT THE INTERSECTION OF SR 1003 (ARABIA ROAD) AT ABERDEEN AND ROCKFISH RAILROAD CROSSING #847 348H NEAR DUNDARRACH. FUNDS ARE NEEDED FOR PRELIMINARY ENGINEERING.	\$40,000.00 Cost \$40,000.00 Fed.
LEE CO. RX-2008E DIVISION	WBS 49320.1.6, FEDERAL NO. 4932018 HIGHWAY-RAIL GRADE CROSSING SAFETY PROJECT AT THE INTERSECTION OF US 1 BUSINESS (CARTHAGE STREET/CHARLOTTE AVENUE) AT ATLANTIC AND WESTERN RAILWAY CROSSING #721 059F IN SANFORD. FUNDS ARE NEEDED FOR PRELIMINARY ENGINEERING.	\$55,000.00 Cost \$55,000.00 Fed.
RANDOLPH CO. RX-2008F DIVISION	WBS 49320.1.7, FEDERAL NO. 4932017 HIGHWAY-RAIL GRADE CROSSING SAFETY PROJECT AT THE INTERSECTION OF SR 2502 (JULIAN AIRPORT ROAD) AT NORFOLK SOUTHERN RAILWAY (NSR) CROSSING #720 943W NEAR LIBERTY. FUNDS ARE NEEDED FOR PRELIMINARY ENGINEERING.	\$50,000.00 Cost \$50,000.00 Fed.

MAY 4, 2023

**NCDOT MAY 2023 BOARD OF TRANSPORTATION AGENDA
APPROVAL OF FUNDS FOR SPECIFIC FEDERAL - AID PROJECTS**

TOWN/COUNTY PROJ. CATEGORY	PROJECT DESCRIPTION	ESTIMATED COST
Division 8		
HOKE CO. W-5708A REGIONAL	WBS 44854.3.1, FEDERAL NO. HSIP-0015(055) US 15/US 501 AT SR 1225 (ASHEMONT ROAD). \$2,586,596.00 HAS PREVIOUSLY BEEN APPROVED FOR CONSTRUCTION. ADDITIONAL FUNDS ARE REQUESTED.	\$340,000.00 Cost \$306,000.00 Fed. \$34,000.00 State

**NCDOT MAY 2023 BOARD OF TRANSPORTATION AGENDA
APPROVAL OF FUNDS FOR SPECIFIC FEDERAL - AID PROJECTS**

TOWN/COUNTY PROJ. CATEGORY	PROJECT DESCRIPTION	ESTIMATED COST
Division 9		
FORSYTH CO. EB-5840 DIVISION	WBS 47297.1.1, FEDERAL NO. 0918134 CONSTRUCT MULTI-USE PATH FROM NC 150 (PETERS CREEK PARKWAY) TO THE STROLLWAY IN WINSTON-SALEM. FUNDS ARE NEEDED FOR PRELIMINARY ENGINEERING.	\$10,000.00 Cost \$8,000.00 Fed. \$2,000.00 Local
DAVIE CO. EB-5958 DIVISION	WBS 48434.3.1, FEDERAL NO. STBGDA-0158(079) BLUE HERON TRAIL FROM TWINS WAY NEAR THE INTERSECTION WITH US 158 WEST TO THE PEDESTRIAN TUNNEL UNDER I-40 IN BERMUDA RUN. \$1,671,200.00 HAS PREVIOUSLY BEEN APPROVED FOR CONSTRUCTION. ADDITIONAL FUNDS ARE REQUESTED.	\$1,598,995.00 Cost \$1,279,196.00 Fed. \$319,799.00 Local
STOKES CO. R-5768 DIVISION	WBS 44670.1.1, FEDERAL NO. STP-0311(035) US 311 (SOUTH MAIN STREET) AT NC 65 AND SR 1928 (STOKESBURG ROAD) AND NC 65 AT NORFOLK SOUTHERN RAIL CROSSING #470 180V IN WALNUT COVE. \$1,133,000.00 HAS PREVIOUSLY BEEN APPROVED FOR PRELIMINARY ENGINEERING. ADDITIONAL FUNDS ARE REQUESTED.	\$50,000.00 Cost \$40,000.00 Fed. \$10,000.00 State
DAVIDSON CO. RX-2009A DIVISION	WBS 49323.1.2, FEDERAL NO. 4932312 HIGHWAY-RAIL GRADE CROSSING SAFETY PROJECT AT THE INTERSECTION OF FIRST STREET AT WINSTON-SALEM SOUTHBOUND RAILWAY COMPANY (WSS) CROSSING #849 955C IN DENTON. FUNDS ARE NEEDED FOR PRELIMINARY ENGINEERING.	\$36,000.00 Cost \$36,000.00 Fed.
FORSYTH CO. RX-2009B DIVISION	WBS 49323.1.3, FEDERAL NO. 4932313 HIGHWAY-RAIL GRADE CROSSING SAFETY PROJECT AT THE INTERSECTION OF SR 2385 (WALKERTOWN- GUTHRIE ROAD) AT NORFOLK SOUTHERN RAILWAY (NSR) CROSSING #722 063Y IN WALKERTOWN. FUNDS ARE NEEDED FOR PRELIMINARY ENGINEERING.	\$50,000.00 Cost \$50,000.00 Fed.

MAY 4, 2023

**NCDOT MAY 2023 BOARD OF TRANSPORTATION AGENDA
APPROVAL OF FUNDS FOR SPECIFIC FEDERAL - AID PROJECTS**

TOWN/COUNTY PROJ. CATEGORY	PROJECT DESCRIPTION	ESTIMATED COST
Division 9		
FORSYTH CO. RX-2009C DIVISION	WBS 49323.1.4, FEDERAL NO. 4932314 HIGHWAY-RAIL GRADE CROSSING SAFETY PROJECT AT THE INTERSECTION OF SR 2381 (WILLISTON ROAD) AT NORFOLK SOUTHERN RAILWAY (NSR) CROSSING #470 210K IN WALKERTOWN. FUNDS ARE NEEDED FOR PRELIMINARY ENGINEERING.	\$50,000.00 Cost \$50,000.00 Fed.
FORSYTH CO. RX-2009D DIVISION	WBS 49323.1.5, FEDERAL NO. 4932315 HIGHWAY-RAIL GRADE CROSSING SAFETY PROJECT AT THE INTERSECTION OF SR 1686 (SHATTALON DRIVE) AT NORFOLK SOUTHERN RAILWAY (NSR) CROSSING #722 024H IN WINSTON-SALEM. FUNDS ARE NEEDED FOR PRELIMINARY ENGINEERING.	\$50,000.00 Cost \$50,000.00 Fed.
FORSYTH CO. U-2579AA REGIONAL	WBS 34839.3.13, FEDERAL NO. 0074226 WINSTON-SALEM NORTHERN BELTWAY EASTERN SECTION (FUTURE I-74) FROM US 311 TO I-40. NEW LOCATION. \$95,100,000.00 HAS PREVIOUSLY BEEN APPROVED FOR CONSTRUCTION. FUNDS NEED TO BE INCREASED \$48,070,440.00 TO REFLECT THE LOW BID RECEIVED. THIS IS A FIVE-YEAR CASH FLOW PROJECT WITH FEDERAL FUNDS OF \$7,691,270.00 IN FY23, \$7,691,270.00 IN FY24, \$7,691,270.00 IN FY25, \$7,691,271.00 IN FY26 AND \$7,691,271.00 IN FY27, AND STATE MATCH OF \$1,922,817.00 IN FY23, \$1,922,817.00 IN FY24, \$1,922,818.00 IN FY25, \$1,922,818.00 IN FY26 AND \$1,922,818.00 IN FY27.	\$48,070,440.00 Cost \$38,456,352.00 Fed. \$9,614,088.00 State

**NCDOT MAY 2023 BOARD OF TRANSPORTATION AGENDA
APPROVAL OF FUNDS FOR SPECIFIC FEDERAL - AID PROJECTS**

TOWN/COUNTY PROJ. CATEGORY	PROJECT DESCRIPTION	ESTIMATED COST
Division 10		
CABARRUS CO. B-5808 REGIONAL	WBS 45762.1.1, FEDERAL NO. NHP-0029(062) REPLACE BRIDGES #120057 AND #120059 OVER IRISH BUFFALO CREEK ON US 29/US 601. \$1,070,000.00 HAS PREVIOUSLY BEEN APPROVED FOR PRELIMINARY ENGINEERING. ADDITIONAL FUNDS ARE REQUESTED.	\$75,000.00 Cost \$60,000.00 Fed. \$15,000.00 State
MECKLENBURG CO. EB-5782 DIVISION	WBS 44524.3.1, FEDERAL NO. CMAQ-1003(175) MCALPINE CREEK GREENWAY FROM GREEN REA ROAD TO JOHNSTON ROAD NEAR PINEVILLE. FUNDS ARE NEEDED FOR CONSTRUCTION TO CONSTRUCT A GREENWAY.	\$7,217,500.00 Cost \$5,774,000.00 Fed. \$1,443,500.00 Local
UNION CO. RX-2010C DIVISION	WBS 49325.1.4, FEDERAL NO. 4932514 HIGHWAY-RAIL GRADE CROSSING SAFETY PROJECT AT THE INTERSECTION OF SR 1008 (INDIAN TRAIL ROAD) AT CSX CROSSING #631 928Y IN INDIAN TRAIL. FUNDS ARE NEEDED FOR PRELIMINARY ENGINEERING.	\$55,000.00 Cost \$55,000.00 Fed.
MECKLENBURG CO. RX-2010D DIVISION	WBS 49325.1.5, FEDERAL NO. 4932515 HIGHWAY-RAIL GRADE CROSSING SAFETY PROJECT AT THE INTERSECTION OF PECAN AVENUE AT CSX CROSSING #631 391N IN CHARLOTTE. FUNDS ARE NEEDED FOR PRELIMINARY ENGINEERING.	\$55,000.00 Cost \$55,000.00 Fed.
MECKLENBURG CO. RX-2010E DIVISION	WBS 49325.1.6, FEDERAL NO. 4932516 HIGHWAY-RAIL GRADE CROSSING SAFETY PROJECT AT THE INTERSECTION OF INDUSTRIAL DRIVE AT NORFOLK SOUTHERN RAILWAY (NSR) CROSSING #716 055T IN CHARLOTTE. FUNDS ARE NEEDED FOR PRELIMINARY ENGINEERING.	\$50,000.00 Cost \$50,000.00 Fed.

**NCDOT MAY 2023 BOARD OF TRANSPORTATION AGENDA
APPROVAL OF FUNDS FOR SPECIFIC FEDERAL - AID PROJECTS**

TOWN/COUNTY PROJ. CATEGORY	PROJECT DESCRIPTION	ESTIMATED COST
Division 10		
CABARRUS CO. U-4910A DIVISION	WBS 40373.3.3, FEDERAL NO. STPDA-1445(008) SR 1445 (DERITA ROAD) FROM SR 2894 (CONCORD MILLS BOULEVARD) TO AVIATION BOULEVARD. \$23,286,337.00 HAS PREVIOUSLY BEEN APPROVED FOR CONSTRUCTION. ADDITIONAL FUNDS ARE REQUESTED.	\$9,000,000.00 Cost \$7,200,000.00 Fed. \$1,800,000.00 Local
MECKLENBURG CO. W-5710S DIVISION	WBS 44856.3.19, FEDERAL NO. HSIP-2108(002) SR 2108 (SUNSET AVENUE) AT SR 2019 (PEACHTREE ROAD) IN CHARLOTTE. \$550,000.00 HAS PREVIOUSLY BEEN APPROVED FOR CONSTRUCTION. ADDITIONAL FUNDS ARE REQUESTED.	\$250,000.00 Cost \$225,000.00 Fed. \$25,000.00 State

**NCDOT MAY 2023 BOARD OF TRANSPORTATION AGENDA
APPROVAL OF FUNDS FOR SPECIFIC FEDERAL - AID PROJECTS**

**TOWN/COUNTY
PROJ.
CATEGORY**

PROJECT DESCRIPTION

**ESTIMATED
COST**

Division 11

WILKES CO.
HS-2011F
DIVISION

WBS 49326.1.7, FEDERAL NO. 4932617
SR 2329 (WOODHAVEN ROAD). INSTALL RUMBLE
STRIPES AND LONG-LIFE PAVEMENT MARKINGS.
FUNDS ARE NEEDED FOR PRELIMINARY
ENGINEERING.

\$1,000.00 Cost
\$900.00 Fed.
\$100.00 State

**NCDOT MAY 2023 BOARD OF TRANSPORTATION AGENDA
APPROVAL OF FUNDS FOR SPECIFIC FEDERAL - AID PROJECTS**

TOWN/COUNTY PROJ. CATEGORY	PROJECT DESCRIPTION	ESTIMATED COST
Division 12		
IREDELL CO. B-5846 DIVISION	WBS 45799.3.1, FEDERAL NO. 1892003 REPLACE BRIDGE #4801189 OVER THE SOUTH YADKIN RIVER ON SR 1892. FUNDS ARE NEEDED FOR CONSTRUCTION.	\$5,000,000.00 Cost \$4,000,000.00 Fed. \$1,000,000.00 State
GASTON CO. RC-2012A DIVISION	WBS 49330.1.2, FEDERAL NO. 4933001 PROPOSED HIGHWAY-RAIL CROSSING CLOSURES AT HANCOCK (CROSSING #716 215E) AND POPLAR (CROSSING #716 217T) STREETS AND EXTENSION OF CRAIG AVE TO NC 7 IN GASTONIA. FUNDS ARE NEEDED FOR PRELIMINARY ENGINEERING.	\$75,000.00 Cost \$75,000.00 Fed.
CLEVELAND CO. RX-2012A DIVISION	WBS 49329.1.2, FEDERAL NO. 4932912 HIGHWAY-RAIL GRADE CROSSING SAFETY PROJECT AT THE INTERSECTION OF LINEBERGER STREET AT CSX CROSSING #631 872G IN SHELBY. FUNDS ARE NEEDED FOR PRELIMINARY ENGINEERING.	\$55,000.00 Cost \$55,000.00 Fed.
IREDELL CO. RX-2012B DIVISION	WBS 49329.1.3, FEDERAL NO. 4932913 HIGHWAY-RAIL GRADE CROSSING SAFETY PROJECT AT THE INTERSECTION OF SR 2339 (WALL STREET) AT NORFOLK SOUTHERN RAILWAY (NSR) CROSSING #729 686G IN STATESVILLE. FUNDS ARE NEEDED FOR PRELIMINARY ENGINEERING.	\$50,000.00 Cost \$50,000.00 Fed.
CATAWBA CO. RX-2012C DIVISION	WBS 49329.1.4, FEDERAL NO. 4932914 HIGHWAY-RAIL GRADE CROSSING SAFETY PROJECT AT THE INTERSECTION OF CENTER STREET AT NORFOLK SOUTHERN RAILWAY (NSR) CROSSING #729 571M IN HICKORY. FUNDS ARE NEEDED FOR PRELIMINARY ENGINEERING.	\$50,000.00 Cost \$50,000.00 Fed.
IREDELL CO. RX-2012D DIVISION	WBS 49329.1.5, FEDERAL NO. 4932915 HIGHWAY-RAIL GRADE CROSSING SAFETY PROJECT AT THE INTERSECTION OF OPAL STREET AT NORFOLK SOUTHERN RAILWAY (NSR) CROSSING #729 684T IN STATESVILLE. FUNDS ARE NEEDED FOR PRELIMINARY ENGINEERING.	\$50,000.00 Cost \$50,000.00 Fed.

MAY 4, 2023

**NCDOT MAY 2023 BOARD OF TRANSPORTATION AGENDA
APPROVAL OF FUNDS FOR SPECIFIC FEDERAL - AID PROJECTS**

TOWN/COUNTY PROJ. CATEGORY	PROJECT DESCRIPTION	ESTIMATED COST
Division 12		
CLEVELAND CO. RX-2012E DIVISION	WBS 49329.1.6, FEDERAL NO. 4932916 HIGHWAY-RAIL GRADE CROSSING SAFETY PROJECT AT THE INTERSECTION OF SR 2263 (MARGRACE ROAD) AT NORFOLK SOUTHERN RAILWAY (NSR) CROSSING #716 273A NEAR KINGS MOUNTAIN. FUNDS ARE NEEDED FOR PRELIMINARY ENGINEERING.	\$50,000.00 Cost \$50,000.00 Fed.
CATAWBA CO. RX-2012F DIVISION	WBS 49329.1.7, FEDERAL NO. 4932917 HIGHWAY-RAIL GRADE CROSSING SAFETY PROJECT AT THE INTERSECTION OF SR 1358 (FOURTH STREET SOUTHWEST) AT NORFOLK SOUTHERN RAILWAY (NSR) CROSSING #729 568E IN HICKORY. FUNDS ARE NEEDED FOR PRELIMINARY ENGINEERING.	\$50,000.00 Cost \$50,000.00 Fed.
CATAWBA CO. RX-2012G DIVISION	WBS 49329.1.8, FEDERAL NO. 4932918 HIGHWAY-RAIL GRADE CROSSING SAFETY PROJECT AT THE INTERSECTION OF SR 1735 (RANKIN AVENUE/MOUNT OLIVE CHURCH ROAD) AT NORFOLK SOUTHERN RAILWAY (NSR) CROSSING #729 612P IN NEWTON. FUNDS ARE NEEDED FOR PRELIMINARY ENGINEERING.	\$50,000.00 Cost \$50,000.00 Fed.
GASTON CO. RX-2012H DIVISION	WBS 49329.1.9, FEDERAL NO. 4932919 HIGHWAY-RAIL GRADE CROSSING SAFETY PROJECT AT THE INTERSECTION OF SR 2412 (LITTLE MOUNTAIN ROAD) AT NORFOLK SOUTHERN RAILWAY (NSR) CROSSING #729 966 NEAR GASTONIA. FUNDS ARE NEEDED FOR PRELIMINARY ENGINEERING.	\$65,000.00 Cost \$65,000.00 Fed.
CATAWBA CO. U-4700A STATEWIDE	WBS 35993.1.7, FEDERAL NO. NHP-0321(039) US 321 FROM US 70 IN HICKORY TO US 321A. \$13,238,263.00 HAS PREVIOUSLY BEEN APPROVED FOR PRELIMINARY ENGINEERING. ADDITIONAL FUNDS ARE REQUESTED.	\$350,000.00 Cost \$280,000.00 Fed. \$70,000.00 State

MAY 4, 2023

**NCDOT MAY 2023 BOARD OF TRANSPORTATION AGENDA
APPROVAL OF FUNDS FOR SPECIFIC FEDERAL - AID PROJECTS**

TOWN/COUNTY PROJ. CATEGORY	PROJECT DESCRIPTION	ESTIMATED COST
Division 13		
RUTHERFORD CO. HL-0065 DIVISION	WBS 50685.1.1, FEDERAL NO. 5068501 US 221A (CHARLOTTE ROAD/MAIN STREET). CONSTRUCT COMPLETE STREET IMPROVEMENTS. FUNDS ARE NEEDED FOR PRELIMINARY ENGINEERING. THIS IS A REBUILDING AMERICAN INFRASTRUCTURE WITH SUSTAINABILITY AND EQUITY (RAISE) GRANT PROJECT.	\$1,425,000.00 Cost \$1,140,000.00 Fed. \$285,000.00 State
MULTIPLE COUNTIES R-5793JB DIVISION	WBS 44923.3.21, FEDERAL NO. 1302107 ADA RAMPS (AMERICANS WITH DISABILITIES ACT) CURB RAMP UPGRADES AT VARIOUS LOCATIONS IN BUNCOMBE, MADISON, AND YANCEY COUNTIES. FUNDS ARE NEEDED FOR CONSTRUCTION. STATE MATCH USES DIVISION CONTRACT RESURFACING FUNDS.	\$985,000.00 Cost \$788,000.00 Fed. \$197,000.00 State
BUNCOMBE CO. RX-2013A DIVISION	WBS 49335.1.2, FEDERAL NO. 4933512 HIGHWAY-RAIL GRADE CROSSING SAFETY PROJECT AT THE INTERSECTION OF SR 1319 (JOHNSTON BOULEVARD) AT BLUE SOUTHERN RAILWAY CROSSING #720 399N IN ASHEVILLE. FUNDS ARE NEEDED FOR PRELIMINARY ENGINEERING.	\$37,000.00 Cost \$37,000.00 Fed.
BUNCOMBE CO. RX-2013B DIVISION	WBS 49335.1.3, FEDERAL NO. 4933513 HIGHWAY-RAIL GRADE CROSSING SAFETY PROJECT AT THE INTERSECTION OF NC 9 (BROADWAY STREET) AT NORFOLK SOUTHERN RAILWAY (NSR) CROSSING #726 262P IN BLACK MOUNTAIN. FUNDS ARE NEEDED FOR PRELIMINARY ENGINEERING.	\$50,000.00 Cost \$50,000.00 Fed.
BURKE CO. RX-2013C DIVISION	WBS 49335.1.4, FEDERAL NO. 4933514 HIGHWAY-RAIL GRADE CROSSING SAFETY PROJECT AT THE INTERSECTION OF HOGAN STREET AT NORFOLK SOUTHERN RAILWAY (NSR) CROSSING #729 506G IN MORGANTON. FUNDS ARE NEEDED FOR PRELIMINARY ENGINEERING.	\$50,000.00 Cost \$50,000.00 Fed.

MAY 4, 2023

**NCDOT MAY 2023 BOARD OF TRANSPORTATION AGENDA
APPROVAL OF FUNDS FOR SPECIFIC FEDERAL - AID PROJECTS**

TOWN/COUNTY PROJ. CATEGORY	PROJECT DESCRIPTION	ESTIMATED COST
---	----------------------------	---------------------------

Division 13

<p>BUNCOMBE CO. W-5813E REGIONAL</p>	<p>WBS 48958.3.6, FEDERAL NO. 0019062 US 19/US 23 /US 74 ALTERNATE (PATTON AVENUE) AT US 19/US 23 BUSINESS (HAYWOOD ROAD)/ SR 1319 (JOHNSTON ROAD) IN ASHEVILLE. \$115,000.00 HAS PREVIOUSLY BEEN APPROVED FOR CONSTRUCTION. ADDITIONAL FUNDS ARE REQUESTED.</p>	<p>\$30,000.00 Cost \$27,000.00 Fed. \$3,000.00 State</p>
--	--	---

**NCDOT MAY 2023 BOARD OF TRANSPORTATION AGENDA
APPROVAL OF FUNDS FOR SPECIFIC FEDERAL - AID PROJECTS**

TOWN/COUNTY PROJ. CATEGORY	PROJECT DESCRIPTION	ESTIMATED COST
Division 14		
JACKSON CO. HS-2014H REGIONAL	WBS 49336.3.9, FEDERAL NO. 0023039 US 23 BUSINESS (HAYWOOD ROAD) AT CHURCH STREET AND SR 1557 (FRONT STREET) AT SR 1558 (DEPOT STREET). FUNDS ARE NEEDED FOR CONSTRUCTION TO INSTALL RECTANGULAR RAPID FLASHING BEACONS (RRFB's) AND UPGRADE CURB RAMPS.	\$96,000.00 Cost \$86,400.00 Fed. \$9,600.00 State
HAYWOOD CO. HS-2014S REGIONAL	WBS 49336.1.20, FEDERAL NO. 4933610 US 19 FROM JACKSON COUNTY TO MAGGIE VALLEY. FUNDS ARE NEEDED FOR PRELIMINARY ENGINEERING.	\$5,000.00 Cost \$4,500.00 Fed. \$500.00 State
SWAIN CO. HS-2014T REGIONAL	WBS 49336.1.21, FEDERAL NO. 4933621 US 19 FROM SR 1336 TO THE JACKSON COUNTY LINE NEAR BRYSON CITY. FUNDS ARE NEEDED FOR PRELIMINARY ENGINEERING.	\$5,000.00 Cost \$4,500.00 Fed. \$500.00 State
MACON CO. HS-2014U STATEWIDE	WBS 49336.1.22, FEDERAL NO. 4933622 US 19 FROM CHEROKEE COUNTY TO SWAIN COUNTY NEAR TOPTON. FUNDS ARE NEEDED FOR PRELIMINARY ENGINEERING.	\$5,000.00 Cost \$4,500.00 Fed. \$500.00 State
HAYWOOD CO. RX-2014A DIVISION	WBS 49338.1.2, FEDERAL NO. 4933812 HIGHWAY-RAIL GRADE CROSSING SAFETY PROJECT AT THE INTERSECTION OF NC 215 (BLACKWELL DRIVE) AT BLUE RIDGE SOUTHERN RAILROAD CROSSING #720 349K NEAR CANTON. FUNDS ARE NEEDED FOR PRELIMINARY ENGINEERING.	\$36,000.00 Cost \$36,000.00 Fed.

**NCDOT MAY 2023 BOARD OF TRANSPORTATION AGENDA
APPROVAL OF FUNDS FOR SPECIFIC FEDERAL - AID PROJECTS**

TOWN/COUNTY PROJ. CATEGORY	PROJECT DESCRIPTION	ESTIMATED COST
Statewide		
STATEWIDE CO. W-5716 SW/REG/DIV	WBS 48923, FEDERAL NO. 00SS105 STATEWIDE SAFETY MANAGEMENT PROGRAM. \$16,500,000.00 HAS PREVIOUSLY BEEN APPROVED FOR PRELIMINARY ENGINEERING. FUNDS NEED TO BE INCREASED \$5,500,000.00 FOR FY23.	\$5,500,000.00 Cost \$4,950,000.00 Fed. \$550,000.00 State

ITEM M SUMMARY - 115 PROJECTS - (TOTAL FEDERAL AND STATE) \$169,674,111.00

**REVISIONS TO THE 2020-2029 STIP
HIGHWAY PROGRAM
STIP ADDITIONS**

DIVISION 1

* FF-0001	NC 12, HATTERAS AND OCRACOCKE ISLAND FERRY	ENGINEERING	FY 2023 -	\$1,070,000	(FLAP)
HYDE	RAMP AND DOCK IMPROVEMENTS.	CONSTRUCTION	FY 2026 -	\$2,430,000	(FLAP)
DARE	<u>ADD NEW FEDERAL LANDS ACCESS PROJECT.</u>			\$3,500,000	
PROJ.CATEGORY					
EXEMPT					

HF-0008	NC 615 (MARSH CAUSEWAY), HQ/ VC ENTRANCE ROAD	CONSTRUCTION	FY 2025 -	\$700,000	(FLAP)
CURRITUCK	TO WEST OF KNOTTS ISLAND ROAD. IMPROVE			\$700,000	
PROJ.CATEGORY	CORRIDOR AT VARIOUS LOCATIONS.				
EXEMPT	<u>ADD NEW FEDERAL LANDS ACCESS PROJECT.</u>				

DIVISION 5

HI-0023	I-885, I-40 TO 0.4 MILES NORTH OF TW ALEXANDER	CONSTRUCTION	FY 2024 -	\$3,300,000	(NHPIM)
DURHAM	DRIVE. PAVEMENT REHABILITATION.			\$3,300,000	
PROJ.CATEGORY	<u>PROGRAMMED TO REFLECT THE LATEST</u>				
STATEWIDE	<u>INTERSTATE MAINTENANCE PRIORITIZATION.</u>				

DIVISION 9

HE-0014	SR 1104 OLD LINWOOD ROAD, CONSTRUCT NEW	ENGINEERING	FY 2023 -	\$400,000	(T)
DAVIDSON	ACCESS ROAD NORTH OF SR 1254 (BROWN STREET)	UTILITIES	FY 2024 -	\$10,000	(T)
PROJ.CATEGORY	AND IMPROVEMENTS TO SR 1104 (OLD LINWOOD	CONSTRUCTION	FY 2024 -	\$4,590,000	(T)
DIVISION	ROAD).		FY 2025 -	\$4,000,000	(T)
	<u>ADD ECONOMIC DEVELOPMENT PROJECT AT</u>			\$9,000,000	
	<u>REQUEST OF DIVISION.</u>				

DIVISION 10

BL-0080	HUNTERSVILLE, CONSTRUCT GREENWAY CULVERT	CONSTRUCTION	FY 2025 -	\$2,600,000	(TADA)
MECKLENBURG	UNDER US 21.		FY 2025 -	\$650,000	(L)
PROJ.CATEGORY	<u>ADD PROJECT AT THE REQUEST OF THE MPO.</u>			\$3,250,000	
DIVISION					

* INDICATES FEDERAL AMENDMENT

**REVISIONS TO THE 2020-2029 STIP
HIGHWAY PROGRAM
STIP ADDITIONS**

DIVISION 10

BL-0081	LEBANON ROAD AND MARGARET WALLACE ROAD,	ENGINEERING	FY 2024 -	\$347,000	(TADA)
MECKLENBURG	MARGARET WALLACE ROAD TO GRISTMILL LANE.		FY 2024 -	\$87,000	(L)
PROJ.CATEGORY	CONSTRUCT SIDEWALK. IDLEWILD ROAD TO LEBANON	RIGHT-OF-WAY	FY 2026 -	\$106,000	(TADA)
DIVISION	ROAD. CONSTRUCT SIDEWALK.		FY 2026 -	\$27,000	(L)
	<u>ADD PROJECT AT THE REQUEST OF THE MPO.</u>	CONSTRUCTION	FY 2027 -	\$865,000	(TADA)
			FY 2027 -	\$216,000	(L)
				<u>\$1,648,000</u>	

BL-0083	SUGAR CREEK ROAD, RUMPLE ROAD TO NEVIN ROAD,	RIGHT-OF-WAY	FY 2025 -	\$377,000	(TADA)
MECKLENBURG	ROMAN ROAD TO GRAHAM STREET. CONSTRUCT		FY 2025 -	\$309,000	(L)
PROJ.CATEGORY	SIDEWALK. INSTALL PEDESTRIAN IMPROVEMENTS AT	CONSTRUCTION	FY 2026 -	\$2,048,000	(TADA)
DIVISION	SOFLEY ROAD.		FY 2026 -	\$1,676,000	(L)
	<u>ADD PROJECT AT THE REQUEST OF THE MPO.</u>			<u>\$4,410,000</u>	

BL-0084	ALBEMARLE ROAD, REDMAN ROAD TO CENTRAL	CONSTRUCTION	FY 2026 -	\$1,756,000	(TADA)
MECKLENBURG	AVENUE. INSTALL SIDEWALK. WILORA LAKE ROAD,		FY 2026 -	\$1,436,000	(L)
PROJ.CATEGORY	ALBEMARLE ROAD TO 100 FEET NORTH OF BARR			<u>\$3,192,000</u>	
DIVISION	DRIVE. CONSTRUCT SIDEWALK AND PEDESTRIAN				
	IMPROVEMENTS AT VARIOUS INTERSECTIONS.				
	<u>ADD PROJECT AT THE REQUEST OF THE MPO.</u>				

BL-0096	BEATY STREET, NC 115 (NORTH MAIN STREET) TO SR	ENGINEERING	FY 2024 -	\$198,000	(TADA)
MECKLENBURG	2158 (GRIFFITH STREET). CONSTRUCT SHARED USE		FY 2024 -	\$132,000	(L)
PROJ.CATEGORY	PATH.	RIGHT-OF-WAY	FY 2026 -	\$361,000	(TADA)
DIVISION	<u>ADD PROJECT AT THE REQUEST OF THE MPO.</u>		FY 2026 -	\$240,000	(L)
		CONSTRUCTION	FY 2028 -	\$1,537,000	(TADA)
			FY 2028 -	\$1,024,000	(L)
				<u>\$3,492,000</u>	

HE-0015	NC 49, PRINCE CIRCLE TO WEST OF GENERAL	CONSTRUCTION	FY 2023 -	\$2,000,000	(T)
CABARRUS	SERVICES DRIVE SW. CONVERT EXISTING FULL			<u>\$2,000,000</u>	
PROJ.CATEGORY	ACCESS CROSSOVER TO REDUCED CONFLICT				
DIVISION	INTERSECTION WITH LEFTOVERS AND SIGNALIZED U-				
	TURN LEFTOVERS.				
	<u>ADD ECONOMIC DEVELOPMENT PROJECT AT THE</u>				
	<u>REQUEST OF THE DIVISION.</u>				

* INDICATES FEDERAL AMENDMENT

**REVISIONS TO THE 2020-2029 STIP
HIGHWAY PROGRAM**

STIP ADDITIONS

DIVISION 10

HL-0111	BEATY STREET, MAIN STREET INTERSECTION.	ENGINEERING	FY 2025 -	\$215,000	(CMAQ)
MECKLENBURG	IMPROVE INTERSECTION.		FY 2025 -	\$143,000	(L)
PROJ.CATEGORY	<u>ADD PROJECT AT THE REQUEST OF THE MPO.</u>	RIGHT-OF-WAY	FY 2027 -	\$203,000	(CMAQ)
EXEMPT			FY 2027 -	\$136,000	(L)
		CONSTRUCTION	FY 2029 -	\$1,645,000	(CMAQ)
			FY 2029 -	<u>\$1,097,000</u>	(L)
				\$3,439,000	
HL-0112	DEARMON ROAD, BENFIELD ROAD TO BROWNE ROAD.	CONSTRUCTION	FY 2024 -	\$5,486,000	(BGDA)
MECKLENBURG	CONSTRUCT COMPLETE STREET IMPROVEMENTS.		FY 2024 -	<u>\$10,189,000</u>	(L)
PROJ.CATEGORY	<u>ADD PROJECT AT THE REQUEST OF THE MPO.</u>			\$15,675,000	
DIVISION					
HL-0113	LANCASTER HIGHWAY, PROVIDENCE ROAD W.	CONSTRUCTION	FY 2026 -	\$1,185,000	(CMAQ)
MECKLENBURG	INTERSECTION. IMPROVE INTERSECTION.		FY 2026 -	<u>\$508,000</u>	(L)
PROJ.CATEGORY	<u>ADD PROJECT AT THE REQUEST OF THE MPO.</u>			\$1,693,000	
EXEMPT					
HL-0115	NC 16 (NORTH BROOME STREET), NORTH CHURCH	ENGINEERING	FY 2025 -	\$369,000	(BGDA)
UNION	STREET TO NC 75. WIDEN TO THREE LANES, IMPROVE		FY 2025 -	\$92,000	(L)
PROJ.CATEGORY	INTERSECTIONS, ADD SIDEWALKS, AND UPGRADE	RIGHT-OF-WAY	FY 2027 -	\$414,000	(BGDA)
REGIONAL	EXISTING PEDESTRIAN FACILITIES.		FY 2027 -	\$103,000	(L)
	<u>ADD PROJECT AT THE REQUEST OF THE MPO.</u>	CONSTRUCTION	FY 2029 -	\$2,479,000	(BGDA)
			FY 2029 -	<u>\$620,000</u>	(L)
				\$4,077,000	
HL-0116	BONDS GROVE CHURCH ROAD, WAXAHAW MARVIN	ENGINEERING	FY 2024 -	\$350,000	(CMAQ)
UNION	ROAD INTERSECTION. CONSTRUCT ROUNDABOUT.		FY 2024 -	\$88,000	(L)
PROJ.CATEGORY	<u>ADD PROJECT AT THE REQUEST OF THE MPO.</u>	RIGHT-OF-WAY	FY 2026 -	\$476,000	(CMAQ)
EXEMPT			FY 2026 -	\$119,000	(L)
		CONSTRUCTION	FY 2028 -	\$3,542,000	(CMAQ)
			FY 2028 -	<u>\$885,000</u>	(L)
				\$5,460,000	
* HL-0117	NC 218, LOVE MILL ROAD INTERSECTION. CONSTRUCT	ENGINEERING	FY 2023 -	\$140,000	(CMAQ)
UNION	ROUNDABOUT.		FY 2023 -	\$60,000	(L)
PROJ.CATEGORY	<u>ADD PROJECT AT THE REQUEST OF THE MPO.</u>	RIGHT-OF-WAY	FY 2024 -	\$216,000	(CMAQ)
EXEMPT			FY 2024 -	\$92,000	(L)
		CONSTRUCTION	FY 2026 -	\$1,644,000	(CMAQ)
			FY 2026 -	<u>\$705,000</u>	(L)
				\$2,857,000	

* INDICATES FEDERAL AMENDMENT

**REVISIONS TO THE 2020-2029 STIP
HIGHWAY PROGRAM
STIP ADDITIONS**

DIVISION 10

HL-0118	STUMPTOWN ROAD, ABERFELD ROAD TO NC 115.	ENGINEERING	FY 2025 -	\$148,000	(BGDA)
MECKLENBURG	WIDEN ROADWAY.		FY 2025 -	\$37,000	(L)
PROJ.CATEGORY	<u>ADD PROJECT AT THE REQUEST OF THE MPO.</u>	RIGHT-OF-WAY	FY 2025 -	\$1,584,000	(BGDA)
REGIONAL			FY 2025 -	\$396,000	(L)
		CONSTRUCTION	FY 2027 -	\$3,424,000	(BGDA)
			FY 2027 -	\$856,000	(L)
				<u>\$6,445,000</u>	

* TL-0030	INDIAN TRAIL, INSTALL TYPE TWO ELECTRIC VEHICLE	CONSTRUCTION	FY 2023 -	\$468,000	(CRPDA)
UNION	CHARGERS AT CROOKED CREEK PARK, CHESTNUT		FY 2023 -	\$117,000	(L)
PROJ.CATEGORY	SQUARE PARK, AND CROSSINGS PATH PARK.			\$585,000	
EXEMPT	<u>ADD PROJECT AT THE REQUEST OF THE MPO.</u>				

TL-0031	UNION COUNTY TRANSPORTATION, LOW EMISSION	CONSTRUCTION	FY 2024 -	\$160,000	(CRPDA)
UNION	ALTERNATIVE FUEL CONVERSION (MOTOR POOL		FY 2024 -	\$40,000	(L)
PROJ.CATEGORY	FACILITY).			\$200,000	
EXEMPT	<u>ADD PROJECT AT THE REQUEST OF THE MPO.</u>				

* TL-0032	CATS, INSTALL ELECTRIC BUS CHARGERS AT NORTH	CONSTRUCTION	FY 2023 -	\$6,546,000	(CRPDA)
MECKLENBURG	DAVIDSON AND SOUTH TRYON BUS GARAGES.		FY 2023 -	\$1,637,000	(L)
PROJ.CATEGORY	<u>ADD PROJECT AT THE REQUEST OF THE MPO.</u>			\$8,183,000	
EXEMPT					

DIVISION 12

BL-0082	NC 115, FAIRVIEW ROAD TO WATERLYNN ROAD.	ENGINEERING	FY 2025 -	\$172,000	(TADA)
IREDELL	CONSTRUCT SHARED USE PATH.		FY 2025 -	\$172,000	(L)
PROJ.CATEGORY	<u>ADD PROJECT AT THE REQUEST OF THE MPO.</u>	RIGHT-OF-WAY	FY 2027 -	\$350,000	(TADA)
DIVISION			FY 2027 -	\$350,000	(L)
		CONSTRUCTION	FY 2029 -	\$1,914,000	(TADA)
			FY 2029 -	\$1,915,000	(L)
				<u>\$4,873,000</u>	

HL-0114	LANGTREE ROAD, PIN OAK LANE TO MOUNT MOURNE	ENGINEERING	FY 2024 -	\$873,000	(BGDA)
IREDELL	LOOP. WIDEN ROADWAY.		FY 2024 -	\$218,000	(L)
PROJ.CATEGORY	<u>ADD PROJECT AT THE REQUEST OF THE MPO.</u>			\$1,091,000	
DIVISION					

* INDICATES FEDERAL AMENDMENT

**REVISIONS TO THE 2020-2029 STIP
HIGHWAY PROGRAM
STIP ADDITIONS**

DIVISION 13

* BL-0076	RICEVILLE ROAD, US 70 TO NORTH OF THE VA	CONSTRUCTION	FY 2023 -	\$830,000	(TADA)
RUTHERFORD	HOSPITAL DRIVEWAY. IMPROVE SIDEWALKS.		FY 2023 -	<u>\$208,000</u>	(L)
PROJ.CATEGORY	<u>ADD PROJECT AT THE REQUEST OF THE MPO.</u>			\$1,038,000	
DIVISION					

BL-0077	SWANNANOA GREENWAY, BLEACHERY ROAD TO	CONSTRUCTION	FY 2028 -	\$2,500,000	(BGDA)
BUNCOMBE	GLENDAL DRIVE. CONSTRUCT GREENWAY.		FY 2028 -	<u>\$625,000</u>	(L)
PROJ.CATEGORY	<u>ADD PROJECT AT THE REQUEST OF THE MPO.</u>			\$3,125,000	
DIVISION					

BL-0079	TEXAS ROAD, REPLACE EXISTING HIGHWAY BRIDGE	CONSTRUCTION	FY 2024 -	\$153,000	(BGDA)
BUNCOMBE	WITH PEDESTRIAN BRIDGE.		FY 2024 -	<u>\$38,000</u>	(L)
PROJ.CATEGORY	<u>ADD PROJECT AT THE REQUEST OF THE MPO.</u>			\$191,000	
DIVISION					

DIVISION 14

BL-0078	ECUSTA TRAIL, US 64 TO TRANSYLVANIA COUNTY	CONSTRUCTION	FY 2027 -	\$10,467,000	(BGDA)
HENDERSON	LINE. CONSTRUCT GREENWAY.		FY 2027 -	<u>\$2,616,000</u>	(L)
PROJ.CATEGORY	<u>ADD PROJECT AT THE REQUEST OF THE MPO.</u>			\$13,083,000	
DIVISION					

HF-0006	US 64, DRY FALLS RECREATION AREA. IMPROVE	ENGINEERING	FY 2024 -	\$500,000	(FLAP)
MACON	PARKING AREA, CONSTRUCT PEDESTRIAN BRIDGE,	CONSTRUCTION	FY 2026 -	<u>\$500,000</u>	(FLAP)
PROJ.CATEGORY	AND CONSTRUCT OBSERVATION PLATFORM.			\$1,000,000	
EXEMPT	<u>ADD NEW FEDERAL LANDS ACCESS PROJECT.</u>				

* HF-0007	SR 1286/ SR 1383 (TSALI ROAD), NC 28 TO END OF	ENGINEERING	FY 2023 -	\$150,000	(FLAP)
SWAIN	MAINTENANCE. RESURFACE AND REPAIR CORRIDOR.	CONSTRUCTION	FY 2025 -	<u>\$1,050,000</u>	(FLAP)
GRAHAM	<u>ADD NEW FEDERAL LANDS ACCESS PROJECT.</u>			\$1,200,000	
PROJ.CATEGORY					
EXEMPT					

* INDICATES FEDERAL AMENDMENT

**REVISIONS TO THE 2020-2029 STIP
HIGHWAY PROGRAM
STIP ADDITIONS**

STATEWIDE

* M-556	STATEWIDE, ADVANCED RIGHT-OF-WAY ACQUISITION	RIGHT-OF-WAY	2023	\$5,000,000	(T)
STATEWIDE	ACCOUNT. REVOLVING ACCOUNT TO FUND		2024	<u>\$1,000,000</u>	(T)
PROJ.CATEGORY	ADVANCED RIGHT-OF-WAY ACQUISITION. FUNDS TO			\$6,000,000	
STATEWIDE	BE REPAID FROM THE STIP PROJECT AT THE TIME				
	THE PROJECT IS FUNDED.				
	<u>ADD PROJECT AT THE REQUEST OF THE RIGHT-OF-WAY BRANCH.</u>				

TC-0020	NCDOT, MODIFYING THE FEDERAL FUNDS RECEIVED	CAPITAL	FY 2023 -	\$350,000	(S)
STATEWIDE	FROM FTA ADMINISTERED BY IMD BASED ON FY 23,		FY 2023 -	\$100,000	(L)
PROJ.CATEGORY	FY 24 GRANTS.		FY 2023 -	\$1,000,000	(5309)
PUBLIC TRANS	<u>ADD PROJECT AT THE REQUEST OF THE INTEGRATED</u>		FY 2024 -	\$300,000	(S)
	<u>MOBILITY DIVISION.</u>		FY 2024 -	\$300,000	(L)
			FY 2024 -	<u>\$2,200,000</u>	(5309)
				\$4,250,000	

STIP MODIFICATIONS

DIVISION 1

* R-5808	US 158, SR 1002 (ACORN HILL ROAD) TO PASQUOTANK	CONSTRUCTION	FY 2023 -	\$197,000	(NHP)
GATES	COUNTY LINE. MODERNIZE ROADWAY.		FY 2024 -	\$11,032,000	(NHP)
PROJ.CATEGORY	<u>COST INCREASE EXCEEDING \$2 MILLION AND 25%</u>		FY 2025 -	\$7,486,000	(NHP)
DIVISION	<u>THRESHOLDS.</u>		FY 2026 -	<u>\$985,000</u>	(NHP)
				\$19,700,000	

DIVISION 2

* HS-2002X	SR 1725 (COUNTY HOME ROAD), AT EXISTING	CONSTRUCTION	FY 2023 -	<u>\$35,000</u>	(HSIP)
PITT	CROSSWALK JUST SOUTH OF DISTRICT PARK DRIVE			\$35,000	
PROJ.CATEGORY	IN GREENVILLE. INSTALL RECTANGULAR RAPID				
DIVISION	FLASHING BEACONS.				
	<u>ADD PROJECT BREAK AT THE REQUEST OF THE TRANSPORTATION MOBILITY AND SAFETY DIVISION.</u>				

DIVISION 3

B-5647	SR 1135 (PROVIDENCE CHURCH ROAD), REPLACE	RIGHT-OF-WAY	FY 2023 -	\$60,000	(BGOFF)
DUPLIN	BRIDGE 300052 OVER ROCKFISH CREEK.	UTILITIES	FY 2023 -	\$25,000	(BGOFF)
PROJ.CATEGORY	<u>ADD UTILITIES IN FY 23 NOT PREVIOUSLY</u>	CONSTRUCTION	FY 2024 -	\$1,140,000	(BGOFF)
DIVISION	<u>PROGRAMMED.</u>		FY 2025 -	<u>\$360,000</u>	(BGOFF)
				\$1,585,000	

* INDICATES FEDERAL AMENDMENT

**REVISIONS TO THE 2020-2029 STIP
HIGHWAY PROGRAM
STIP MODIFICATIONS**

DIVISION 4

* HS-2004T HALIFAX PROJ.CATEGORY REGIONAL	US 158, US 158 FROM EASTERN LITTLETON TOWN LIMITS AND 0.15 MILES WEST OF SR 1432 (EVERETTS SCHOOL ROAD). INSTALL RUMBLE STRIPES WITH SIX-INCH PAVEMENT MARKINGS. <u>ADD PROJECT BREAK AT THE REQUEST OF THE TRANSPORTATION MOBILITY AND SAFETY DIVISION.</u>	CONSTRUCTION	FY 2023 - <u>\$230,000</u> \$230,000 (HSIP)
* HS-2004U NASH WILSON PROJ.CATEGORY REGIONAL	NC 58, NC 58 FROM NORTHERN STATONSBURG TOWN LIMITS TO 0.3 MILES NORTH OF SR 1622 (EVANSDALE ROAD) IN WILSON COUNTY. NC 58 FROM SOUTH OF SR 1314 (THOMPSON CHAPEL CHURCH ROAD) IN WILSON COUNTY TO SOUTHERN NASHVILLE TOWN LIMIT IN NASH COUNTY. NC 58 FROM SOUTH OF SR 1004 (TAYLORS STORE ROAD) TO SOUTHERN CASTALIA TOWN LIMIT IN NASH COUNTY. INSTALL RUMBLE STRIPES WITH SIX-INCH PAVEMENT MARKINGS. <u>ADD PROJECT BREAK AT THE REQUEST OF THE TRANSPORTATION MOBILITY AND SAFETY DIVISION.</u>	CONSTRUCTION	FY 2023 - <u>\$301,000</u> \$301,000 (HSIP)
* HS-2004V WAYNE WILSON EDGECOMBE PROJ.CATEGORY REGIONAL	NC 111, NC 111 FROM WAYNE/DUPLIN COUNTY LINE TO SR 1727 (DOLLARD TOWN ROAD). NC 111 FROM US 70 BYPASS OVERPASS TO NC 222. NC 111/NC 222 FROM FREMONT LIMITS TO SR 1513 (RED HILL ROAD). NC 111/NC 222 FROM STANTONSBURG LIMITS TO SARATOGA LIMITS. NC 111 FROM NC 222 IN WILSON COUNTY TO SR 1344 (SARA LEE ROAD) IN EDGECOMBE COUNTY. NC 111 FROM PRINCEVILLE TO EDGECOMBE/MARTIN COUNTY LINE. INSTALL RUMBLE STRIPS WITH SIX-INCH PAVEMENT MARKINGS. <u>ADD PROJECT BREAK AT THE REQUEST OF THE TRANSPORTATION MOBILITY AND SAFETY DIVISION.</u>	CONSTRUCTION	FY 2023 - <u>\$2,161,000</u> \$2,161,000 (HSIP)
* HS-2004X NASH HALIFAX PROJ.CATEGORY REGIONAL	NC 43, NC 43 FROM 0.5 MILES NORTH OF SR 1425 (CASTALIA ROAD) IN NASH COUNTY TO NC 561 IN HALIFAX COUNTY. INSTALL RUMBLE STRIPS. <u>ADD PROJECT BREAK AT THE REQUEST OF THE TRANSPORTATION MOBILITY AND SAFETY DIVISION.</u>	CONSTRUCTION	FY 2023 - <u>\$361,000</u> \$361,000 (HSIP)

* INDICATES FEDERAL AMENDMENT

**REVISIONS TO THE 2020-2029 STIP
HIGHWAY PROGRAM
STIP MODIFICATIONS**

DIVISION 5

* HL-0006	US 401, SR 1393 (HILLTOP-NEEDMORE ROAD) / SR 2751	RIGHT-OF-WAY	FY 2023 -	\$2,133,000	(NHPBA)
WAKE	(HILLTOP ROAD) / SR 2752 (AIR PARK ROAD)		FY 2024 -	\$267,000	(NHPBA)
PROJ.CATEGORY	INTERSECTION AND SR 1375 (LAKE WHEELER ROAD)		FY 2025 -	\$100,000	(NHPBA)
EXEMPT	INTERSECTION IN FUQUAY-VARINA. CONVERT TO		FY 2026 -	\$100,000	(NHPBA)
	REDUCED-CONFLICT INTERSECTIONS AND REALIGN	UTILITIES	FY 2023 -	\$509,000	(NHPBA)
	SR 2751 TO INTERSECT OPPOSITE SR 1375.	CONSTRUCTION	FY 2025 -	\$10,593,000	(NHPBA)
	<u>ACCELERATE RIGHT-OF-WAY FROM FY 24 TO FY 23</u>		FY 2026 -	\$10,647,000	(NHPBA)
	<u>TO ALIGN WITH PROJECT SCHEDULE.</u>		FY 2027 -	\$5,660,000	(NHPBA)
				<u>\$30,009,000</u>	
HL-0008C	NC 50 (BENSON ROAD), SR 2812 (TIMBER DRIVE)	CONSTRUCTION	FY 2024 -	\$525,000	(BA)
WAKE	INTERSECTION IN GARNER. INTERSECTION			\$525,000	
PROJ.CATEGORY	IMPROVEMENTS.				
EXEMPT	<u>TO ALLOW ADDITIONAL TIME FOR PLANNING AND</u>				
	<u>DESIGN. DELAY CONSTRUCTION FROM FY 23 TO FY 24.</u>				
HL-0008H	SR 1371 / SR 1375 (LAKE WHEELER ROAD), SR 1375	CONSTRUCTION	FY 2024 -	\$18,000	(BA)
WAKE	(SIMPKINS ROAD) / NON-SYSTEM (SIMPKINS FARM		FY 2025 -	\$1,732,000	(BA)
PROJ.CATEGORY	LANE) INTERSECTION. INTERSECTION			\$1,750,000	
EXEMPT	IMPROVEMENTS.				
	<u>TO ALLOW ADDITIONAL TIME FOR PLANNING AND</u>				
	<u>DESIGN. DELAY CONSTRUCTION FROM FY 23 TO FY 24.</u>				
* HL-0028	US 401, SR 1404 (MILL CREEK DRIVE) / IDEAL LANE IN	CONSTRUCTION	FY 2023 -	\$10,000	(BGDA)
WAKE	FUQUAY-VARINA. IMPROVE INTERSECTION.		FY 2023 -	\$2,000	(L)
PROJ.CATEGORY	<u>DELETE RIGHT-OF-WAY ACQUISITION AT THE</u>		FY 2024 -	\$992,000	(BGDA)
EXEMPT	<u>REQUEST OF DIVISION.</u>		FY 2024 -	\$248,000	(L)
				<u>\$1,252,000</u>	
HL-0031	SR 1007 (POOLE ROAD), SR 2233 (SMITHFIELD ROAD).	CONSTRUCTION	FY 2024 -	\$3,000	(S)
WAKE	UPGRADE INTERSECTION.		FY 2024 -	\$14,000	(BGDA)
PROJ.CATEGORY	<u>TO ALLOW ADDITIONAL TIME FOR PLANNING AND</u>		FY 2025 -	\$336,000	(S)
DIVISION	<u>DESIGN. DELAY CONSTRUCTION FROM FY 23 TO FY 24.</u>		FY 2025 -	\$1,347,000	(BGDA)
				<u>\$1,700,000</u>	

* INDICATES FEDERAL AMENDMENT

**REVISIONS TO THE 2020-2029 STIP
HIGHWAY PROGRAM
STIP MODIFICATIONS**

DIVISION 5

HL-0033 WAKE PROJ.CATEGORY DIVISION	(SR 3126) AIRPORT BOULEVARD, GARDEN SQUARE LANE TO SR 1637 (CHURCH STREET) IN MORRISVILLE. CONSTRUCT ROADWAY ON NEW LOCATION. <u>TO ALLOW ADDITIONAL TIME FOR PLANNING AND DESIGN, DELAY CONSTRUCTION FROM FY 23 TO FY 24.</u>	UTILITIES CONSTRUCTION	FY 2023 - \$60,000 (BGDA) FY 2023 - \$40,000 (L) FY 2024 - \$2,540,000 (BGDA) FY 2024 - \$635,000 (L) FY 2025 - \$5,008,000 (BGDA) FY 2025 - \$1,252,000 (L) FY 2026 - \$932,000 (BGDA) FY 2026 - <u>\$233,000</u> (L) \$10,700,000
HL-0050 WAKE PROJ.CATEGORY DIVISION	SR 1349 (DILLARD DRIVE), VILLAGE TAVERN ROAD TO SR 1319 (JONES FRANKLIN ROAD) IN RALEIGH. INSTALL TWO WAY LEFT TURN LANE. <u>TO ALLOW ADDITIONAL TIME FOR PLANNING AND DESIGN, DELAY CONSTRUCTION FROM FY 23 TO FY 24.</u>	RIGHT-OF-WAY CONSTRUCTION	FY 2023 - \$64,000 (S) FY 2023 - \$110,000 (BGDA) FY 2024 - \$406,000 (S) FY 2024 - <u>\$692,000</u> (BGDA) \$1,272,000
HS-20050 WARREN PROJ.CATEGORY STATEWIDE	US 1 / US 158, US 1 / US 158 AT SR 1237 (MASON DREWRY ROAD). INTERSECTION REALIGNMENT. <u>ADD PROJECT BREAK AT REQUEST OF TRANSPORTATION MOBILITY AND SAFETY DIVISION.</u>	UTILITIES CONSTRUCTION	FY 2024 - \$80,000 (HSIP) FY 2024 - <u>\$335,000</u> (HSIP) \$415,000
HS-2005P PERSON PROJ.CATEGORY REGIONAL	US 501, US 501 AT NC 57 (HILLSBOROUGH ROAD). INSTALL TRAFFIC SIGNAL. <u>ADD PROJECT BREAK AT REQUEST OF TRANSPORTATION MOBILITY AND SAFETY DIVISION.</u>	CONSTRUCTION	FY 2024 - <u>\$260,000</u> (HSIP) \$260,000
HS-2005Q WAKE PROJ.CATEGORY DIVISION	SR 1142 (HUMIE OLIVE ROAD), SR 1142 (HUMIE OLIVE ROAD) AT BLAZING TRAIL DRIVE/DRIVEWAY ACCESS TO APEX FRIENDSHIP HIGH AND ELEMENTARY SCHOOLS. INSTALL TRAFFIC AND PEDESTRIAN SIGNALS. <u>ADD PROJECT BREAK AT REQUEST OF TRANSPORTATION MOBILITY AND SAFETY DIVISION.</u>	CONSTRUCTION	FY 2024 - <u>\$130,000</u> (HSIP) \$130,000
HS-2005R WAKE PROJ.CATEGORY DIVISION	SR 3120 (MORRISVILLE PARKWAY), SR 3120 (MORRISVILLE PARKWAY) AT SR 3043 (FERSON ROAD) / GREEN HOPE SCHOOL ROAD. IMPROVE PEDESTRIAN CROSSING. <u>ADD PROJECT BREAK AT REQUEST OF TRANSPORTATION MOBILITY AND SAFETY DIVISION.</u>	CONSTRUCTION	FY 2024 - <u>\$50,000</u> (HSIP) \$50,000

* INDICATES FEDERAL AMENDMENT

**REVISIONS TO THE 2020-2029 STIP
HIGHWAY PROGRAM
STIP MODIFICATIONS**

DIVISION 5

* U-4726HO DURHAM PROJ.CATEGORY DIVISION	CARPENTER - FLETCHER ROAD, WOODCROFT PARKWAY (CITY MAINTAINED) TO SR 1945 (ALSTON AVENUE). CONSTRUCT BIKE LANES AND SIDEWALKS. <u>ADD RIGHT-OF-WAY IN FY 23 NOT PREVIOUSLY PROGRAMMED.</u>	RIGHT-OF-WAY CONSTRUCTION	FY 2023 - \$22,000 (TADA) FY 2023 - \$5,000 (L) FY 2024 - \$6,305,000 (BGANY) FY 2024 - <u>\$1,576,000</u> (L) \$7,908,000
---	--	----------------------------------	--

DIVISION 6

EB-6030 CUMBERLAND PROJ.CATEGORY DIVISION	US 401 BYPASS (SKIBO ROAD), CONSTRUCT SIDEWALK FROM RICHWOOD COURT TO NC 24 (BRAGG BOULEVARD). <u>TO ALLOW ADDITIONAL TIME FOR PLANNING AND DESIGN. DELAY CONSTRUCTION FROM FY 23 TO FY 24.</u>	RIGHT-OF-WAY CONSTRUCTION	FY 2023 - \$60,000 (TADA) FY 2023 - \$15,000 (L) FY 2024 - \$360,000 (TADA) FY 2024 - <u>\$90,000</u> (L) \$525,000
--	--	----------------------------------	---

* HI-0017 ROBESON PROJ.CATEGORY STATEWIDE	US 74 (FUTURE I-74), US 74 (FUTURE I-74) FROM THE SCOTLAND COUNTY LINE TO I-74/US 74 BUSINESS. PAVEMENT REHABILITATION. <u>COST INCREASE EXCEEDING \$2 MILLION AND 25% THRESHOLDS.</u>	CONSTRUCTION	FY 2023 - \$479,000 (NHFP) FY 2023 - \$541,000 (NHPIM) FY 2024 - \$2,717,000 (NHFP) FY 2024 - <u>\$3,063,000</u> (NHPIM) \$6,800,000
--	---	--------------	--

* HS-2006W HARNETT CUMBERLAND PROJ.CATEGORY STATEWIDE	US 401, BETWEEN FAYETTEVILLE AND HARNETT COUNTY (MILEPOST 20 - 27.7), BETWEEN CUMBERLAND COUNTY AND LILLINGTON (MILEPOST 0 - 9.5), AND BETWEEN LILLINGTON AND WAKE COUNTY (MILEPOST 12.5 - 22.1). INSTALL RUMBLE STRIPES WITH PAVEMENT MARKINGS AND RAISED PAVEMENT MARKERS. <u>ADD PROJECT BREAK AT THE REQUEST OF THE TRANSPORTATION MOBILITY AND SAFETY DIVISION.</u>	CONSTRUCTION	FY 2023 - <u>\$975,000</u> (HSIP) \$975,000
---	---	--------------	--

* HS-2006Y HARNETT PROJ.CATEGORY DIVISION	SR 1115 (BUFFALO LAKE ROAD), FROM NC 27 TO NC 87. INSTALL RUMBLE STRIPES WITH PAVEMENT MARKINGS AND RAISED PAVEMENT MARKERS. <u>ADD PROJECT BREAK AT THE REQUEST OF THE TRANSPORTATION MOBILITY AND SAFETY DIVISION.</u>	CONSTRUCTION	FY 2023 - <u>\$235,000</u> (HSIP) \$235,000
--	---	--------------	--

* INDICATES FEDERAL AMENDMENT

**REVISIONS TO THE 2020-2029 STIP
HIGHWAY PROGRAM
STIP MODIFICATIONS**

DIVISION 7

B-5716	SR 1138 (LINDSEY BRIDGE ROAD), REPLACE BRIDGE	RIGHT-OF-WAY	FY 2023 -	\$610,000	(BGOFF)
ROCKINGHAM	780140 OVER DAN RIVER.	CONSTRUCTION	FY 2024 -	\$741,000	(BGOFF)
PROJ.CATEGORY	<u>TO ALLOW ADDITIONAL TIME FOR PLANNING AND</u>		FY 2025 -	\$4,277,000	(BGOFF)
DIVISION	<u>DESIGN. DELAY CONSTRUCTION FROM FY 23 TO FY 24.</u>		FY 2026 -	\$1,083,000	(BGOFF)
				<u>\$6,711,000</u>	

B-5722	SR 1169 (ISLAND DRIVE), REPLACE BRIDGE 780277	RIGHT-OF-WAY	FY 2023 -	\$200,000	(BGOFF)
ROCKINGHAM	OVER BEAVER CREEK.	CONSTRUCTION	FY 2024 -	\$752,000	(BGOFF)
PROJ.CATEGORY	<u>TO ALLOW ADDITIONAL TIME FOR PLANNING AND</u>		FY 2025 -	\$1,248,000	(BGOFF)
DIVISION	<u>DESIGN. DELAY CONSTRUCTION FROM FY 23 TO FY 24.</u>			<u>\$2,200,000</u>	

I-5955A	I-40, SOUTH BUFFALO CREEK BRIDGE EAST OF US 220	CONSTRUCTION	FY 2024 -	\$101,000	(NHPIM)
GUILFORD	(FREEMAN MILL ROAD) TO EAST OF SR 3037 / SR 4240		FY 2025 -	\$7,546,000	(NHPIM)
PROJ.CATEGORY	(EAST GATE CITY BOULEVARD) IN GREENSBORO.		FY 2026 -	\$2,453,000	(NHPIM)
STATEWIDE	REHABILITATE BRIDGES 400678, 400367, 400364, 400357, 400349, 400348, 400340, 400339, 400336, 400329, 400327, 400299, 400291, AND 400285.			<u>\$10,100,000</u>	
	<u>ADD SEGMENT "A" NOT PREVIOUSLY PROGRAMMED AT THE REQUEST OF THE DIVISION.</u>				

TG-6811B	ALAMANACE COUNTY TRANSPORTATION, FUNDING	CAPITAL	FY 2024 -	\$10,000	(L)
ALAMANACE	FOR PREVENTIVE MAINTENANCE.		FY 2024 -	\$40,000	(5307)
PROJ.CATEGORY	<u>MODIFY FUNDING IN FY 24, FY 25, FY 26, FY 27 AND FY</u>		FY 2025 -	\$10,000	(L)
PUBLIC TRANS	<u>28 AT THE REQUEST OF THE MPO.</u>		FY 2025 -	\$40,000	(5307)
			FY 2026 -	\$10,000	(L)
			FY 2026 -	\$40,000	(5307)
			FY 2027 -	\$10,000	(L)
			FY 2027 -	\$40,000	(5307)
			FY 2028 -	\$10,000	(L)
			FY 2028 -	\$40,000	(5307)
				<u>\$250,000</u>	

* INDICATES FEDERAL AMENDMENT

**REVISIONS TO THE 2020-2029 STIP
HIGHWAY PROGRAM
STIP MODIFICATIONS**

DIVISION 7

TO-5214 ALAMANCE PROJ.CATEGORY PUBLIC TRANS	ALAMANACE COUNTY TRANSPORTATION, OPERATING OPERATIONS FOR ALAMANCE COUNTY TRANSPORTATION IN THE BURLINGTON URBAN AREA - THROUGH NCDOT <u>MODIFY FUNDING IN FY 23, FY 24, FY 25, FY 26, FY 27</u> <u>AND FY 28 AT THE REQUEST OF THE MPO.</u>	FY 2023 - \$340,000 (L) FY 2023 - \$680,000 (5307) FY 2024 - \$805,000 (L) FY 2024 - \$805,000 (5307) FY 2025 - \$805,000 (L) FY 2025 - \$805,000 (5307) FY 2026 - \$805,000 (L) FY 2026 - \$805,000 (5307) FY 2027 - \$805,000 (L) FY 2027 - \$805,000 (5307) FY 2028 - \$805,000 (L) FY 2028 - <u>\$805,000</u> (5307) \$9,070,000
--	--	--

* U-5532E GUILFORD PROJ.CATEGORY DIVISION	VARIOUS, BIG TREE WAY-WENDOVER AVENUE TO ELKHOUND TRAIL; SHELBY DRIVE-BIG TREE WAY TO EDITH LANE; HEWITT STREET-NORWOLK STREET TO MERRITT DRIVE; BRIDFORD PARKWAY AND HORNADAY ROAD-WENDOVER AVENUE TO EXISTING WEST OF NICHOLAS ROAD. <u>ADD SEGMENT "E" NOT PREVIOUSLY PROGRAMMED</u> <u>AT THE REQUEST OF THE MPO.</u>	CONSTRUCTION FY 2023 - \$1,949,000 (TADA) FY 2023 - <u>\$487,000</u> (L) \$2,436,000
--	--	---

* U-5532F GUILFORD PROJ.CATEGORY DIVISION	VARIOUS, HOLDEN ROAD SIDEWALK (1) HOLDEN ROAD FROM WALKER AVENUE TO SPRING GARDEN STREET - BOTH SIDES, 2) HOLDEN ROAD FROM DARDEN ROAD TO VANDALIA ROAD - WEST SIDE, 3) HOLDEN ROAD FROM MADISON AVENUE TO WALKER AVENUE - BOTH SIDES, 4) RANKIN ROAD / MARTIN AVENUE SOUTH SIDE OF RANKIN ROAD FROM SUMMIT AVENUE TO MARTIN AVENUE. <u>ADD SEGMENT "F" NOT PREVIOUSLY PROGRAMMED</u> <u>AT THE REQUEST OF THE MPO.</u>	CONSTRUCTION FY 2023 - \$1,518,000 (TADA) FY 2023 - <u>\$380,000</u> (L) \$1,898,000
--	--	---

* U-5532G GUILFORD PROJ.CATEGORY DIVISION	VARIOUS, SIDEWALK IMPROVEMENTS AT VARIOUS LOCATIONS IN GREENSBORO. <u>ADD SEGMENT "G" NOT PREVIOUSLY PROGRAMMED</u> <u>AT THE REQUEST OF THE MPO.</u>	CONSTRUCTION FY 2023 - \$920,000 (TADA) FY 2023 - <u>\$230,000</u> (L) \$1,150,000
--	--	---

* INDICATES FEDERAL AMENDMENT

**REVISIONS TO THE 2020-2029 STIP
HIGHWAY PROGRAM
STIP MODIFICATIONS**

DIVISION 7

* U-5532H GUILFORD PROJ.CATEGORY DIVISION	VARIOUS, NORTH SIDE OF SEMINOLE DRIVE FROM JOSEHPINE BOYD STREET; NORTH SIDE OF WHIPPOORWILL DRIVE FROM PENNYDALE DRIVE TO JANE STREET; AND NORTH SIDE OF WEST BESSEMER AVENUE FROM GRECADE STREET TO HILL STREET <u>ADD SEGMENT "H" NOT PREVIOUSLY PROGRAMMED AT THE REQUEST OF THE MPO.</u>	CONSTRUCTION	FY 2023 - \$536,000 (TADA) FY 2023 - <u>\$134,000</u> (L) \$670,000
--	--	--------------	---

* U-5532I GUILFORD PROJ.CATEGORY DIVISION	VARIOUS, HOLDEN ROAD FROM MADISON AVENUE TO FRIENDLY AVENUE; COTSWOLD AVENUE FROM BATTLEGROUND AVENUE TO COTSWOLD TERRACE (NORTH SIDE); GREENBRIAR ROAD FROM CHURCH STREET TO ELM STREET (NORTH SIDE); AND SWING ROAD FROM MARKET STREET TO BURNT POPLAR ROAD. <u>ADD SEGMENT "I" NOT PREVIOUSLY PROGRAMMED AT THE REQUEST OF THE MPO.</u>	ENGINEERING RIGHT-OF-WAY CONSTRUCTION	FY 2023 - \$65,000 (TADA) FY 2023 - \$16,000 (L) FY 2023 - \$320,000 (TADA) FY 2023 - \$80,000 (L) FY 2023 - \$934,000 (TADA) FY 2023 - <u>\$234,000</u> (L) \$1,649,000
--	---	---	--

U-6017 ALAMANCE PROJ.CATEGORY DIVISION	NC 54 (EAST HARDEN STREET), NC 49 (EAST ELM STREET) IN GRAHAM. INTERSECTION IMPROVEMENTS. <u>TO ALLOW ADDITIONAL TIME FOR PLANNING AND DESIGN. DELAY CONSTRUCTION FROM FY 23 TO FY 24.</u>	CONSTRUCTION	FY 2024 - \$21,000 (T) FY 2025 - \$1,703,000 (T) FY 2026 - <u>\$376,000</u> (T) \$2,100,000
---	---	--------------	--

DIVISION 9

* BL-0020 FORSYTH PROJ.CATEGORY DIVISION	DEPOT STREET, US 311 (MAIN STREET) TO SR 1992 (SULLIVANTOWN ROAD) IN WALKERTOWN. CONSTRUCT SIDEWALK. <u>DELETE RIGHT-OF-WAY AT THE REQUEST OF DIVISION.</u>	CONSTRUCTION	FY 2023 - \$383,000 (BGDA) FY 2023 - <u>\$96,000</u> (L) \$479,000
---	---	--------------	--

* EB-5956 FORSYTH PROJ.CATEGORY DIVISION	SR 1992 (SULLIVANTOWN ROAD), US 311 AT HARLEY DRIVE TO WALKERTOWN HIGH/MIDDLE SCHOOL IN WALKERTOWN. INSTALL BICYCLE AND PEDESTRIAN FACILITIES AND CONSTRUCT SIDEWALK. <u>DELETE RIGHT-OF-WAY AT THE REQUEST OF DIVISION.</u>	CONSTRUCTION	FY 2023 - \$448,000 (BGDA) FY 2023 - <u>\$112,000</u> (L) \$560,000
---	---	--------------	---

* INDICATES FEDERAL AMENDMENT

**REVISIONS TO THE 2020-2029 STIP
HIGHWAY PROGRAM
STIP MODIFICATIONS**

DIVISION 9

HE-0009	NC 152, INTERSECTION WITH PROPOSED ACCESS	CONSTRUCTION	FY 2024 -	\$39,000	(T)
ROWAN	ROAD EAST OF I-85 / US 601 IN CHINA GROVE. WIDEN		FY 2025 -	\$2,894,000	(T)
PROJ.CATEGORY	PAVEMENT AND CONSTRUCT ROUNDABOUT.		FY 2026 -	\$967,000	(T)
DIVISION	<u>TO ALLOW ADDITIONAL TIME FOR PLANNING AND DESIGN, DELAY CONSTRUCTION FROM FY 23 TO FY 24.</u>			\$3,900,000	

HL-0016	US 311 (MAIN STREET), SR 1977 (PINE HALL ROAD) IN	RIGHT-OF-WAY	FY 2024 -	\$72,000	(BGDA)
FORSYTH	WALKERTOWN. REALIGN INTERSECTION AND ADD		FY 2024 -	\$18,000	(L)
PROJ.CATEGORY	AUXILIARY TURN LANES.	CONSTRUCTION	FY 2024 -	\$412,000	(BGDA)
EXEMPT	<u>TO ALLOW ADDITIONAL TIME FOR PLANNING AND DESIGN, DELAY RIGHT-OF-WAY FROM FY 23 TO FY 24 AND CONSTRUCTION FROM FY 23 TO FY 24.</u>		FY 2024 -	\$103,000	(L)
				\$605,000	

* I-5950	I-85, I-285 / US 29 / US 52 / US 70 TO NORTH OF US 64.	CONSTRUCTION	FY 2023 -	\$16,717,000	(NHPIM)
DAVIDSON	PAVEMENT REHABILITATION.		FY 2024 -	\$11,540,000	(NHPIM)
PROJ.CATEGORY	<u>COST INCREASE EXCEEDING \$2 MILLION AND 25%</u>			\$28,257,000	
STATEWIDE	<u>THRESHOLDS.</u>				

* U-4741OK	PIEDMONT REGIONAL GREENWAY, WINSTON-SALEM -	RIGHT-OF-WAY	FY 2023 -	\$720,000	(TADA)
FORSYTH	PIEDMONT REGIONAL GREENWAY		FY 2023 -	\$180,000	(L)
PROJ.CATEGORY	<u>ADD SEGMENT "OK" NOT PREVIOUSLY PROGRAMMED</u>			\$900,000	
DIVISION	<u>AT THE REQUEST OF THE MPO.</u>				

DIVISION 10

B-6046	SR 1917 (BETHLEHEM CHURCH ROAD), REPLACE	CONSTRUCTION	FY 2024 -	\$291,000	(BGOFF)
STANLY	BRIDGE 830102 OVER LONG CREEK.		FY 2025 -	\$1,409,000	(BGOFF)
PROJ.CATEGORY	<u>TO ALLOW ADDITIONAL TIME FOR UTILITY</u>			\$1,700,000	
DIVISION	<u>RELOCATION, DELAY CONSTRUCTION FROM FY 23 TO FY 24.</u>				

* EB-5969	NC 51 MULTI-USE PATH, TRADE STREET TO	ENGINEERING	FY 2023 -	\$371,000	(TADA)
MECKLENBURG	INDEPENDENCE POINTE PARKWAY. CONSTRUCT		FY 2023 -	\$93,000	(L)
PROJ.CATEGORY	MULTI-USE PATH ON SOUTH SIDE OF NC 51.	RIGHT-OF-WAY	FY 2025 -	\$692,000	(TADA)
DIVISION	<u>ADD PRELIMINARY ENGINEERING AND RIGHT-OF-WAY</u>		FY 2025 -	\$173,000	(L)
	<u>AT THE REQUEST OF THE MPO. TO REFLECT THE</u>	CONSTRUCTION	FY 2027 -	\$860,000	(TAANY)
	<u>LATEST DELIVERY SCHEDULE, DELAY</u>		FY 2027 -	\$77,000	(TADA)
	<u>CONSTRUCTION FROM FY 25 TO FY 27.</u>		FY 2027 -	\$234,000	(L)
				\$2,500,000	

* INDICATES FEDERAL AMENDMENT

**REVISIONS TO THE 2020-2029 STIP
HIGHWAY PROGRAM
STIP MODIFICATIONS**

DIVISION 10

* HS-2010L MECKLENBURG PROJ.CATEGORY STATEWIDE	SR 5901 (BILLY GRAHAM PARKWAY), NC 49 (TRYON ROAD) TO I-85. INSTALL GUARDRAIL. <u>ADD PROJECT BREAK AT THE REQUEST OF THE TRANSPORTATION MOBILITY AND SAFETY DIVISION.</u>	CONSTRUCTION	FY 2023 -	\$960,000 \$960,000	(HSIP)
---	---	--------------	-----------	------------------------	--------

* I-5715 MECKLENBURG PROJ.CATEGORY STATEWIDE	I-77, NC 73 INTERCHANGE. UPGRADE EXISTING INTERCHANGE TO SPLIT DIAMOND CONFIGURATION. <u>COST INCREASE EXCEEDING \$2 MILLION AND 25% THRESHOLDS.</u>	RIGHT-OF-WAY UTILITIES CONSTRUCTION	FY 2023 - FY 2024 - FY 2025 - FY 2026 - FY 2027 - FY 2023 - FY 2024 - FY 2026 - FY 2027 - FY 2028 - FY 2029 -	\$1,164,000 \$7,019,000 \$7,019,000 \$1,899,000 \$1,899,000 \$1,500,000 \$1,500,000 \$618,000 \$28,124,000 \$22,985,000 \$10,073,000 \$83,800,000	(NHP) (NHP) (NHP) (NHP) (NHP) (NHP) (NHP) (NHP) (NHP) (NHP) (NHP) (NHP)
---	---	---	---	--	--

* I-6052 MECKLENBURG PROJ.CATEGORY STATEWIDE	I-277 (BROOKSHIRE FREEWAY), WEST OF I-77 TO EAST OF I-77. BRIDGE REHABILITATION. <u>COST INCREASE EXCEEDING \$2 MILLION AND 25% THRESHOLDS.</u>	CONSTRUCTION	FY 2023 - FY 2023 - FY 2023 - FY 2024 - FY 2024 - FY 2024 -	\$4,084,000 \$2,390,000 \$597,000 \$4,466,000 \$2,610,000 \$653,000 \$14,800,000	(NHFP) (BGDA) (S(M)) (NHFP) (BGDA) (S(M))
---	--	--------------	--	--	--

P-5750A ANSON PROJ.CATEGORY REGIONAL	CSX SF LINE, CONSTRUCT SIDING EXTENSION IN POLKTON. <u>REMOVE RIGHT-OF-WAY AT THE REQUEST OF THE RAIL DIVISION.</u>	CONSTRUCTION	FY 2024 - FY 2024 - FY 2025 - FY 2025 - FY 2026 - FY 2026 -	\$1,145,000 \$3,520,000 \$1,584,000 \$4,868,000 \$471,000 \$1,449,000 \$13,037,000	(DP) (T) (DP) (T) (DP) (T)
---	--	--------------	--	--	---

* INDICATES FEDERAL AMENDMENT

**REVISIONS TO THE 2020-2029 STIP
HIGHWAY PROGRAM
STIP MODIFICATIONS**

DIVISION 10

* R-2632AB MECKLENBURG PROJ.CATEGORY REGIONAL	NC 73, NC 115 TO SR 2693 (DAVIDSON-CONCORD ROAD). WIDEN TO MULTI-LANES. <u>COST INCREASE EXCEEDING \$2 MILLION AND 25% THRESHOLDS.</u>	RIGHT-OF-WAY UTILITIES CONSTRUCTION	FY 2023 - \$184,000 (NHP) FY 2024 - \$2,213,000 (NHP) FY 2025 - \$2,213,000 (NHP) FY 2026 - \$2,030,000 (NHP) FY 2027 - \$1,660,000 (NHP) FY 2023 - \$2,550,000 (NHP) FY 2024 - \$2,550,000 (NHP) FY 2026 - \$493,000 (NHP) FY 2026 - \$73,000 (BGDA) FY 2026 - \$18,000 (S(M)) FY 2027 - \$20,655,000 (NHP) FY 2027 - \$3,047,000 (BGDA) FY 2027 - \$762,000 (S(M)) FY 2028 - \$16,708,000 (NHP) FY 2028 - \$2,464,000 (BGDA) FY 2028 - \$616,000 (S(M)) FY 2029 - \$9,331,000 (NHP) FY 2029 - \$1,376,000 (BGDA) FY 2029 - \$344,000 (S(M)) AFTER FY 2029 - \$2,122,000 (NHP) AFTER FY 2029 - \$313,000 (BGDA) AFTER FY 2029 - \$78,000 (S(M)) <hr/> \$71,800,000
--	---	---	---

U-4913A MECKLENBURG PROJ.CATEGORY DIVISION	SR 3174 (IDLEWILD ROAD), SR 3175 (STALLINGS ROAD) TO I-485. WIDEN ROADWAY. <u>SEGMENT U-4913 INTO SEGMENTS A AND B AT THE REQUEST OF THE DIVISION.</u>	RIGHT-OF-WAY UTILITIES CONSTRUCTION	FY 2026 - \$750,000 (T) FY 2026 - \$250,000 (T) FY 2028 - \$2,200,000 (T) FY 2029 - \$2,200,000 (T) <hr/> \$5,400,000
---	---	---	---

U-4913B MECKLENBURG UNION	SR 3174 / SR 1501 (IDLEWILD ROAD), I-485 TO SR 1524 (STEVENS MILL ROAD). WIDEN ROADWAY. <u>SEGMENT U-4913 INTO SEGMENTS A AND B AT THE REQUEST OF THE DIVISION.</u>	RIGHT-OF-WAY UTILITIES CONSTRUCTION	AFTER FY 2029 - \$14,886,000 (T) AFTER FY 2029 - \$636,000 (T) AFTER FY 2029 - \$21,500,000 (T) <hr/> \$37,022,000
---------------------------------	--	---	---

* INDICATES FEDERAL AMENDMENT

**REVISIONS TO THE 2020-2029 STIP
HIGHWAY PROGRAM
STIP MODIFICATIONS**

DIVISION 10

U-5108	NORTHCROSS DRIVE EXTENSION, NC 73 IN	CONSTRUCTION	FY 2024 -	\$1,163,000	(BGANY)
MECKLENBURG	HUNTERSVILLE TO WESTMORELAND ROAD IN		FY 2024 -	\$176,000	(L)
PROJ.CATEGORY	CORNELIUS. CONSTRUCT ROAD ON NEW LOCATION.		FY 2024 -	\$41,000	(S(M))
TRANSITION	<u>TO ALLOW ADDITIONAL TIME FOR UTILITY</u>		FY 2025 -	\$7,578,000	(BGANY)
	<u>RELOCATION, DELAY CONSTRUCTION FROM FY 23 TO</u>		FY 2025 -	\$1,144,000	(L)
	<u>FY 24.</u>		FY 2025 -	\$268,000	(S(M))
			FY 2026 -	\$3,959,000	(BGANY)
			FY 2026 -	\$598,000	(L)
			FY 2026 -	\$140,000	(S(M))
			FY 2027 -	\$703,000	(BGANY)
			FY 2027 -	\$106,000	(L)
			FY 2027 -	\$24,000	(S(M))
				\$15,900,000	
U-5808	SR 1362 (CHESTNUT LANE CONNECTOR), SR 1367	UTILITIES	FY 2023 -	\$1,200,000	(T)
UNION	(MATTHEWS INDIAN TRAIL ROAD) TO SR 1368	CONSTRUCTION	FY 2024 -	\$135,000	(T)
PROJ.CATEGORY	(GRIBBLE ROAD). CONSTRUCT ROAD ON NEW		FY 2025 -	\$6,152,000	(T)
DIVISION	LOCATION. INTERSECTION OF US 74 AND EXISTING		FY 2026 -	\$5,176,000	(T)
	SR 1362 (CHESTNUT LANE CONNECTOR).		FY 2027 -	\$2,038,000	(T)
	CONSTRUCT INTERSECTION IMPROVEMENTS.			\$14,701,000	
	<u>TO ALLOW ADDITIONAL TIME FOR UTILITY</u>				
	<u>RELOCATION, DELAY CONSTRUCTION FROM FY 23 TO</u>				
	<u>FY 24.</u>				
U-5873	NC 115, POTTS STREET. CONSTRUCT	CONSTRUCTION	FY 2024 -	\$377,000	(CMAQ)
MECKLENBURG	IMPROVEMENTS.		FY 2024 -	\$94,000	(S(M))
PROJ.CATEGORY	<u>TO ALLOW ADDITIONAL TIME FOR PLANNING AND</u>		FY 2025 -	\$2,061,000	(CMAQ)
EXEMPT	<u>DESIGN, DELAY CONSTRUCTION FROM FY 23 TO FY 24.</u>		FY 2025 -	\$515,000	(S(M))
			FY 2026 -	\$295,000	(CMAQ)
			FY 2026 -	\$74,000	(S(M))
				\$3,416,000	
U-5906	SR 2195 (TORRENCE CHAPEL ROAD), SR 5544 (WEST	CONSTRUCTION	FY 2024 -	\$577,000	(T(DA))
MECKLENBURG	CATAWBA AVENUE). INTERSECTION IMPROVEMENTS.		FY 2025 -	\$1,994,000	(T(DA))
PROJ.CATEGORY	<u>TO ALLOW ADDITIONAL TIME FOR PLANNING AND</u>		FY 2026 -	\$1,009,000	(T(DA))
DIVISION	<u>DESIGN, DELAY CONSTRUCTION FROM FY 23 TO FY 24.</u>		FY 2027 -	\$161,000	(T(DA))
				\$3,741,000	
U-6087	POTTER ROAD AT WESLEY CHAPEL ROAD.	CONSTRUCTION	FY 2024 -	\$1,006,000	(CMAQ)
UNION	CONSTRUCT ROUNDABOUT.		FY 2024 -	\$262,000	(BGDA)
PROJ.CATEGORY	<u>TO ALLOW ADDITIONAL TIME FOR PLANNING AND</u>		FY 2024 -	\$319,000	(L)
DIVISION	<u>DESIGN, DELAY CONSTRUCTION FROM FY 23 TO FY 24.</u>		FY 2024 -	\$293,000	(S(M))
				\$1,880,000	

* INDICATES FEDERAL AMENDMENT

**REVISIONS TO THE 2020-2029 STIP
HIGHWAY PROGRAM
STIP MODIFICATIONS**

DIVISION 10

U-6092 MECKLENBURG PROJ.CATEGORY EXEMPT	DAVIDSON-CONCORD ROAD AT ROBERT WALKER DRIVE. CONSTRUCT ROUNDABOUT. <u>TO ALLOW ADDITIONAL TIME FOR RIGHT-OF-WAY ACQUISITION, DELAY CONSTRUCTION FROM FY 23 TO FY 24.</u>	RIGHT-OF-WAY CONSTRUCTION	FY 2023 - \$515,000 (CMAQ) FY 2023 - \$130,000 (L) FY 2024 - \$966,000 (CMAQ) FY 2024 - \$1,011,000 (BGDA) FY 2025 - \$494,000 (L) \$3,116,000
--	--	----------------------------------	---

W-5710AD UNION PROJ.CATEGORY DIVISION	SR 1005 (LANDSFORD ROAD), SR 1937 (OLD PAGELAND MARSHVILLE ROAD). INSTALL AN ALL WAY STOP. <u>ADD PROJECT BREAK AT THE REQUEST OF THE TRANSPORTATION MOBILITY AND SAFETY DIVISION.</u>	CONSTRUCTION	FY 2024 - \$30,000 (HSIP) \$30,000
--	---	--------------	---------------------------------------

W-5710AH UNION PROJ.CATEGORY REGIONAL	NC 200 (LANCASTER HIGHWAY), SR 1137 (POTTER ROAD). CONSTRUCT SAFETY IMPROVEMENTS. <u>ADD PROJECT BREAK AT THE REQUEST OF THE TRANSPORTATION MOBILITY AND SAFETY DIVISION.</u>	CONSTRUCTION	FY 2024 - \$2,200,000 (HSIP) \$2,200,000
--	--	--------------	---

W-5710AN UNION PROJ.CATEGORY DIVISION	SR 1009 (OLD CHARLOTTE HIGHWAY), WILLIAMS ROAD IN MONROE. CONSTRUCT SAFETY IMPROVEMENTS. <u>ADD PROJECT BREAK AT THE REQUEST OF THE TRANSPORTATION MOBILITY AND SAFETY DIVISION.</u>	CONSTRUCTION	FY 2024 - \$570,000 (HSIP) \$570,000
--	---	--------------	---

W-5710AO CABARRUS PROJ.CATEGORY DIVISION	SR 1002 (OLD SALISBURY CONCORD ROAD), SR 2400 (IRISH POTATO ROAD) NEAR KANNAPOLIS. CONSTRUCT SAFETY IMPROVEMENTS. <u>ADD PROJECT BREAK AT THE REQUEST OF THE TRANSPORTATION MOBILITY AND SAFETY DIVISION.</u>	CONSTRUCTION	FY 2024 - \$1,000,000 (HSIP) \$1,000,000
---	--	--------------	---

DIVISION 11

R-5913B YADKIN SURRY PROJ.CATEGORY HWY FUNDS	US 21 BUSINESS, BRIDGE #850021 OVER YADKIN RIVER. REHABILITATE STRUCTURE AND WIDEN SIDEWALKS. <u>TO ALIGN PROJECT SCHEDULE WITH R-5913A, DELAY CONSTRUCTION FROM FY 23 TO FY 25.</u>	CONSTRUCTION	FY 2025 - \$266,000 (HFB) FY 2026 - \$1,134,000 (HFB) \$1,400,000
--	---	--------------	---

* INDICATES FEDERAL AMENDMENT

**REVISIONS TO THE 2020-2029 STIP
HIGHWAY PROGRAM
STIP MODIFICATIONS**

DIVISION 11

U-4700CB	US 321, SR 1809/1952 (PINE MOUNTAIN ROAD).	CONSTRUCTION	FY 2024 -	\$735,000	(NHP)
CALDWELL	UPGRADE INTERSECTION TO REDUCED CONFLICT		FY 2025 -	\$5,109,000	(NHP)
PROJ.CATEGORY	INTERSECTION - WITHIN THE LIMITS OF U-4700 C.		FY 2026 -	<u>\$3,356,000</u>	(NHP)
STATEWIDE	<u>TO ALLOW ADDITIONAL TIME FOR RIGHT-OF-WAY ACQUISITION, DELAY CONSTRUCTION FROM FY 23 TO FY 24.</u>			\$9,200,000	

U-4700CC	US 321, SR 1108 (MISSION ROAD). UPGRADE	CONSTRUCTION	FY 2024 -	\$556,000	(NHP)
CALDWELL	INTERSECTION TO REDUCED CONFLICT		FY 2025 -	\$3,813,000	(NHP)
PROJ.CATEGORY	INTERSECTION - WITHIN THE LIMITS OF U-4700 C.		FY 2026 -	<u>\$1,531,000</u>	(NHP)
STATEWIDE	<u>TO ALLOW ADDITIONAL TIME FOR RIGHT-OF-WAY ACQUISITION, DELAY CONSTRUCTION FROM FY 23 TO FY 24.</u>			\$5,900,000	

U-6033	US 64/ NC 18, SR 1142 (CALLICO ROAD)	UTILITIES	FY 2023 -	\$450,000	(T)
CALDWELL	INTERSECTION. CONSTRUCT INTERSECTION	CONSTRUCTION	FY 2023 -	\$22,000	(T)
PROJ.CATEGORY	IMPROVEMENTS.		FY 2024 -	\$1,556,000	(T)
DIVISION	<u>ADD UTILITIES AT THE REQUEST OF THE DIVISION.</u>		FY 2025 -	<u>\$668,000</u>	(T)
				\$2,696,000	

DIVISION 12

BL-0033	NC 274 (TRYON COURTHOUSE ROAD), PINE SPRINGS	ENGINEERING	FY 2023 -	\$150,000	(CMAQ)
GASTON	DRIVE TO TRYON ELEMENTARY SCHOOL. CONSTRUCT		FY 2023 -	\$38,000	(L)
PROJ.CATEGORY	SIDEWALK ON WEST SIDE OF ROADWAY FROM PINE	RIGHT-OF-WAY	FY 2024 -	\$40,000	(CMAQ)
EXEMPT	SPRINGS TO COURT TERRACE. INSTALL MID-BLOCK		FY 2024 -	\$10,000	(L)
	CROSSWALK AND CONSTRUCT SIDEWALK ON EAST	CONSTRUCTION	FY 2025 -	\$801,000	(CMAQ)
	SIDE OF ROADWAY TO TRYON ELEMENTARY SCHOOL.		FY 2025 -	\$200,000	(L)
	<u>DELAY CONSTRUCTION FROM FY 24 TO FY 25. THIS IS</u>		FY 2026 -	\$358,000	(CMAQ)
	<u>A CORRECTION TO AN AMENDMENT THAT WAS</u>		FY 2026 -	<u>\$90,000</u>	(L)
	<u>APPROVED IN NOVEMBER 2022.</u>			\$1,687,000	

EB-5828	CENTENNIAL BOULEVARD, NORTH OXFORD STREET	RIGHT-OF-WAY	FY 2023 -	\$25,000	(BGDA)
CATAWBA	TO NORTH LOOKOUT STREET. CONSTRUCT		FY 2023 -	\$6,000	(L)
PROJ.CATEGORY	SIDEWALK.	CONSTRUCTION	FY 2024 -	\$433,000	(BGANY)
DIVISION	<u>TO ALLOW ADDITIONAL TIME FOR PLANNING AND</u>		FY 2024 -	<u>\$108,000</u>	(L)
	<u>DESIGN, DELAY RIGHT-OF-WAY FROM FY 22 TO FY 23</u>			\$572,000	
	<u>AND CONSTRUCTION FROM FY 23 TO FY 24.</u>				

* INDICATES FEDERAL AMENDMENT

**REVISIONS TO THE 2020-2029 STIP
HIGHWAY PROGRAM
STIP MODIFICATIONS**

DIVISION 12

W-5712R LINCOLN PROJ.CATEGORY DIVISION	SR 1003 (BUFFALO SHOALS ROAD), SR 1343 (IVEY CHURCH ROAD). CONSTRUCT SAFETY IMPROVEMENTS. <u>ADD PROJECT BREAK AT THE REQUEST OF THE TRANSPORTATION MOBILITY AND SAFETY DIVISION.</u>	CONSTRUCTION	FY 2025 - <u>\$625,000</u> \$625,000	(HSIP)
---	--	--------------	---	--------

W-5712U CLEVELAND PROJ.CATEGORY REGIONAL	NC 150, MILEPOST 19.3 TO GASTON COUNTY LINE AND FROM THE CLEVELAND COUNTY LINE TO MILEPOST 1.2. CONSTRUCT SAFETY IMPROVEMENTS. <u>ADD PROJECT BREAK AT THE REQUEST OF THE TRANSPORTATION MOBILITY AND SAFETY DIVISION.</u>	CONSTRUCTION	FY 2025 - <u>\$625,000</u> \$625,000	(HSIP)
---	---	--------------	---	--------

DIVISION 13

B-5876 RUTHERFORD PROJ.CATEGORY STATEWIDE	US 74, REPLACE BRIDGE 800083 AND BRIDGE 800084 OVER SECOND BROAD RIVER. <u>TO REFLECT THE LATEST DELIVERY SCHEDULE, DELAY CONSTRUCTION FROM FY 23 TO FY 25.</u>	CONSTRUCTION	FY 2025 - \$3,513,000 FY 2026 - \$4,675,000 FY 2027 - <u>\$1,610,000</u> \$9,798,000	(BGLT5) (BGLT5) (BGLT5)
--	--	--------------	---	-------------------------------

BL-0006 BUNCOMBE PROJ.CATEGORY DIVISION	CONSTRUCT PEDESTRIAN IMPROVEMENTS AT VARIOUS LOCATIONS WITHIN THE CITY OF ASHEVILLE (PRIMARILY WITHIN SCHOOL ZONES). <u>TO REFLECT THE LATEST DELIVERY SCHEDULE, DELAY PRELIMINARY ENGINEERING FROM FY 23 TO FY 26 AND CONSTRUCTION FROM FY 25 TO FY 26.</u>	ENGINEERING CONSTRUCTION	FY 2026 - \$60,000 FY 2026 - \$15,000 FY 2026 - \$600,000 FY 2026 - <u>\$150,000</u> \$825,000	(BGDA) (L) (BGDA) (L)
--	---	---------------------------------	--	--------------------------------

EB-5547B BUNCOMBE PROJ.CATEGORY DIVISION	BLACK MOUNTAIN RIVERWALK GREENWAY, CONSTRUCT MULTI-USE PATH FROM BLACK MOUNTAIN AVENUE TO THE INTO THE OAKS TRAIL. <u>TO ALLOW ADDITIONAL TIME FOR PLANNING AND DESIGN, DELAY RIGHT-OF-WAY FROM FY 22 TO FY 23 AND CONSTRUCTION FROM FY 23 TO FY 24.</u>	RIGHT-OF-WAY CONSTRUCTION	FY 2023 - \$16,000 FY 2023 - \$4,000 FY 2024 - \$1,241,000 FY 2024 - <u>\$310,000</u> \$1,571,000	(BGANY) (L) (BGANY) (L)
---	---	----------------------------------	---	----------------------------------

* EB-5774A BUNCOMBE PROJ.CATEGORY DIVISION	NC 251 (RIVERSIDE DRIVE) WOODFIN GREENWAY, US 19/23/70 (EXIT 25) TO THE MILLS AT RIVERSIDE. CONSTRUCT MULTI-USE PATH. <u>SEGMENT EB-5774 INTO SEGMENTS A AND B AT THE REQUEST OF THE DIVISION AND MPO.</u>	RIGHT-OF-WAY CONSTRUCTION	FY 2023 - \$1,911,000 FY 2023 - \$1,495,000 FY 2023 - \$853,000 FY 2025 - \$4,808,000 FY 2025 - <u>\$1,202,000</u> \$10,269,000	(CRPDA) (TADA) (L) (BGDA) (L)
---	---	----------------------------------	--	---

* INDICATES FEDERAL AMENDMENT

**REVISIONS TO THE 2020-2029 STIP
HIGHWAY PROGRAM
STIP MODIFICATIONS**

DIVISION 13

EB-5774B BUNCOMBE PROJ.CATEGORY DIVISION	BEAVERDAM CREEK GREENWAY, THE MILLS AT RIVERSIDE TO US 25. CONSTRUCT MULTI-USE PATH. <u>SEGMENT EB-5774 INTO SEGMENTS A AND B AT THE REQUEST OF THE DIVISION AND MPO.</u>	RIGHT-OF-WAY CONSTRUCTION	FY 2025 - \$176,000 (BGDA) FY 2025 - \$310,000 (TADA) FY 2025 - \$122,000 (L) FY 2026 - \$2,000,000 (BGANY) FY 2026 - \$760,000 (BGDA) FY 2026 - \$690,000 (L) <u>\$4,058,000</u>
EB-5821 BUNCOMBE PROJ.CATEGORY DIVISION	REEMS CREEK GREENWAY, CONSTRUCT MULTI-USE PATH ALONG REEMS CREEK CORRIDOR FROM WESTERN EDGE OF TOWN OF WEAVERVILLE TO KARPEN SOCCER FIELDS <u>TO REFLECT THE LATEST DELIVERY SCHEDULE, DELAY PRELIMINARY ENGINEERING FROM FY 23 TO FY 29 AT THE REQUEST OF THE MPO.</u>	ENGINEERING	FY 2029 - \$480,000 (BGDA) FY 2029 - \$120,000 (L) <u>\$600,000</u>
EB-5823 BUNCOMBE PROJ.CATEGORY DIVISION	BENT CREEK GREENWAY, CONSTRUCT MULTI-USE PATH FROM HOMINY CREEK RIVER PARK TO WESTERN NC FARMERS MARKET. <u>TO REFLECT THE LATEST DELIVERY SCHEDULE, DELAY PRELIMINARY ENGINEERING FROM FY 23 TO FY 29 AT THE REQUEST OF THE MPO.</u>	ENGINEERING	FY 2029 - \$320,000 (BGDA) FY 2029 - \$80,000 (L) <u>\$400,000</u>
EB-5831 BUNCOMBE PROJ.CATEGORY DIVISION	COXE AVENUE, PATTON AVENUE TO SHORT COXE AVENUE. IMPROVE BICYCLE AND PEDESTRIAN INFRASTRUCTURE. <u>TO REFLECT THE LATEST DELIVERY SCHEDULE, DELAY PRELIMINARY ENGINEERING FROM FY 22 TO FY 23.</u>	ENGINEERING RIGHT-OF-WAY CONSTRUCTION	FY 2023 - \$420,000 (BGDA) FY 2023 - \$300,000 (TADA) FY 2023 - \$180,000 (L) FY 2024 - \$240,000 (BGDA) FY 2024 - \$60,000 (L) FY 2025 - \$76,000 (BGANY) FY 2025 - \$1,247,000 (BGDA) FY 2025 - \$332,000 (L) FY 2026 - \$3,893,000 (BGANY) FY 2026 - \$973,000 (L) FY 2027 - \$3,037,000 (BGANY) FY 2027 - \$759,000 (L) FY 2028 - \$546,000 (BGANY) FY 2028 - \$137,000 (L) <u>\$12,200,000</u>
HL-0013 BUNCOMBE PROJ.CATEGORY DIVISION	9TH STREET, REPLACE BRIDGE 100522 OVER TOMAHAWK BRANCH IN BLACK MOUNTAIN. <u>TO ALLOW ADDITIONAL TIME FOR RIGHT-OF-WAY ACQUISITION, DELAY CONSTRUCTION FROM FY 23 TO FY 24.</u>	RIGHT-OF-WAY CONSTRUCTION	FY 2023 - \$96,000 (BGANY) FY 2023 - \$24,000 (L) FY 2024 - \$288,000 (BGANY) FY 2024 - \$256,000 (BGDA) FY 2024 - \$136,000 (L) <u>\$800,000</u>

* INDICATES FEDERAL AMENDMENT

**REVISIONS TO THE 2020-2029 STIP
HIGHWAY PROGRAM
STIP MODIFICATIONS**

DIVISION 14

* BL-0007 HENDERSON	ECUSTA RAIL-TRAIL, KANUGA ROAD TO US 64/BATTLE CREEK. CONSTRUCT MULTI-USE PATH.	ENGINEERING	FY 2023 - \$290,000 (BGDA)
PROJ.CATEGORY	<u>COST INCREASE EXCEEDING \$2 MILLION AND 25% THRESHOLDS.</u>	CONSTRUCTION	FY 2023 - \$73,000 (L)
DIVISION			FY 2023 - \$4,470,000 (BGANY)
			FY 2023 - \$2,318,000 (BGDA)
			FY 2023 - \$160,000 (TADA)
			FY 2023 - <u>\$1,737,000</u> (L)
			\$9,048,000
 EB-5946 HENDERSON	 TOWN OF MILLS RIVER, NC 280, FRENCH BROAD RIVER TO NC 191 (HAYWOOD ROAD). CONSTRUCT MULTI-USE PATH.	 ENGINEERING	 FY 2026 - \$300,000 (TADA)
PROJ.CATEGORY	<u>TO REFLECT THE LATEST DELIVERY SCHEDULE. DELAY PRELIMINARY ENGINEERING FROM FY 23 TO FY 26.</u>		FY 2026 - <u>\$75,000</u> (L)
DIVISION			\$375,000
 * HS-2014F CLAY	 SR 1100 (OLD HIGHWAY 64 WEST), SR 1135 (SETTAWIG ROAD) NEAR BRASSTOWN. WIDEN AND INSTALL GUARDRAIL.	 CONSTRUCTION	 FY 2023 - \$129,000 (HSIP)
PROJ.CATEGORY	<u>DELETE RIGHT-OF-WAY ACQUISITION AT THE REQUEST OF THE TRANSPORTATION MOBILITY AND SAFETY DIVISION.</u>		FY 2024 - <u>\$191,000</u> (HSIP)
DIVISION			\$320,000
 HS-2014P JACKSON CHEROKEE MACON	 INSTALL LONG LIFE PAVEMENT MARKINGS ALONG VARIOUS PRIMARY AND SECONDARY ROUTES.	 CONSTRUCTION	 FY 2024 - <u>\$2,955,000</u> (HSIP)
PROJ.CATEGORY	<u>DELAY CONSTRUCTION FROM FY 23 TO FY 24. THIS IS A CORRECTION TO AN AMENDMENT THAT WAS APPROVED IN JANUARY 2023.</u>		\$2,955,000
REGIONAL			
 R-5865 TRANSYLVANIA	 US 276, US 64 TO AVERY CREEK TRAIL HEAD. WIDEN TO 3-LANES WITH BICYCLE LANES. NC FLAP DOT 276(1).	 ENGINEERING	 FY 2023 - \$5,770,000 (FLAP)
PROJ.CATEGORY	<u>DELETE CONSTRUCTION. ADD FUNDING TO PRELIMINARY ENGINEERING AT THE REQUEST OF THE DIVISION AND EASTERN FEDERAL LANDS.</u>		FY 2023 - <u>\$680,000</u> (S(M))
EXEMPT			\$6,450,000

* INDICATES FEDERAL AMENDMENT

**REVISIONS TO THE 2020-2029 STIP
HIGHWAY PROGRAM
STIP MODIFICATIONS**

DIVISION 14

U-5839	US 276 (RUSS AVENUE), US 23/74 TO US 23 BUSINESS	ENGINEERING	FY 2023 -	\$222,000	(T)
HAYWOOD	(MAIN STREET). UPGRADE CORRIDOR.		FY 2024 -	\$222,000	(T)
PROJ.CATEGORY	<u>TO ALLOW ADDITIONAL TIME FOR PLANNING AND</u>		FY 2025 -	\$222,000	(T)
DIVISION	<u>DESIGN. DELAY CONSTRUCTION FROM FY 23 TO FY 24.</u>		FY 2026 -	\$222,000	(T)
			FY 2027 -	\$222,000	(T)
			FY 2028 -	\$222,000	(T)
			FY 2029 -	\$222,000	(T)
			AFTER FY 2029 -	\$1,110,000	(T)
		BUILD NC ROW	FY 2023 -	\$186,000	(T)
			FY 2024 -	\$186,000	(T)
			FY 2025 -	\$186,000	(T)
			FY 2026 -	\$186,000	(T)
			FY 2027 -	\$186,000	(T)
			FY 2028 -	\$186,000	(T)
			FY 2029 -	\$186,000	(T)
			AFTER FY 2029 -	\$930,000	(T)
		CONSTRUCTION	FY 2024 -	\$243,000	(T)
			FY 2025 -	\$9,848,000	(T)
			FY 2026 -	\$8,739,000	(T)
			FY 2027 -	<u>\$5,770,000</u>	(T)
				\$29,496,000	

W-5714E	US 64, SR 1119 (SAPPHIRE POSTOFFICE ROAD) AT	CONSTRUCTION	FY 2024 -	\$975,000	(HSIP)
JACKSON	CHRYSLER CURVE NEAR SAPPHIRE. CONSTRUCT			\$975,000	
PROJ.CATEGORY	SAFETY IMPROVEMENTS.				
REGIONAL	<u>ADD PROJECT BREAK AT THE REQUEST OF THE</u>				
	<u>TRANSPORTATION MOBILITY AND SAFETY DIVISION.</u>				

STATEWIDE

TA-6665	STATEWIDE, 5311 CAPITAL PROJECTS FOR RURAL	CAPITAL	FY 2023 -	\$5,850,000	(S)
STATEWIDE	AREAS		FY 2023 -	\$1,200,000	(L)
PROJ.CATEGORY	<u>MODIFY FUNDING IN FY 23, FY 24 AT THE REQUEST OF</u>		FY 2023 -	\$23,000,000	(5311)
PUBLIC TRANS	<u>THE INTEGRATED MOBILITY DIVISION.</u>		FY 2024 -	\$10,000,000	(S)
			FY 2024 -	\$10,000,000	(L)
			FY 2024 -	<u>\$42,000,000</u>	(5311)
				\$92,050,000	

TC-0021	NCDOT, 5339 STATEWIDE RURAL	CAPITAL	FY 2023 -	\$12,925,000	(S)
STATEWIDE	<u>MODIFY FUNDING IN FY 23, FY 24 AT THE REQUEST OF</u>		FY 2023 -	\$1,000,000	(L)
PROJ.CATEGORY	<u>THE INTEGRATED MOBILITY DIVISION.</u>		FY 2023 -	\$13,700,000	(5339)
PUBLIC TRANS			FY 2024 -	\$1,100,000	(S)
			FY 2024 -	\$1,100,000	(L)
			FY 2024 -	<u>\$8,200,000</u>	(5339)
				\$38,025,000	

* INDICATES FEDERAL AMENDMENT

**REVISIONS TO THE 2020-2029 STIP
HIGHWAY PROGRAM
STIP MODIFICATIONS**

STATEWIDE

TM-0027	NCDOT, 5311 ADMINISTRATIVE FUNDS FOR FTA	ADMINISTRATIVE	FY 2023 -	\$988,000	(S)
STATEWIDE	GRANTS		FY 2023 -	\$2,868,000	(L)
PROJ.CATEGORY	<u>MODIFY FUNDING IN FY 24 AT THE REQUEST OF THE</u>		FY 2023 -	\$15,428,000	(5311)
PUBLIC TRANS	<u>INTEGRATED MOBILITY DIVISION.</u>		FY 2024 -	\$3,200,000	(S)
			FY 2024 -	\$3,200,000	(L)
			FY 2024 -	<u>\$26,000,000</u>	(5311)
				\$51,684,000	

TM-0028	NCDOT, 5311 OPERATING FUNDS FOR FTA GRANTS	OPERATIONS	FY 2023 -	\$647,000	(L)
STATEWIDE	<u>MODIFY FUNDING IN FY 24 AT THE REQUEST OF THE</u>		FY 2023 -	\$647,000	(5311)
PROJ.CATEGORY	<u>INTEGRATED MOBILITY DIVISION.</u>		FY 2024 -	\$1,000,000	(S)
PUBLIC TRANS			FY 2024 -	\$6,600,000	(L)
			FY 2024 -	<u>\$6,600,000</u>	(5311)
				\$15,494,000	

TM-0031	NCDOT, RTAP STATEWIDE FUNDS FOR FTA GRANTS	ADMINISTRATIVE	FY 2023 -	\$698,000	(RTAP)
STATEWIDE	<u>MODIFY FUNDING IN FY 24 AT THE REQUEST OF THE</u>		FY 2024 -	<u>\$650,000</u>	(RTAP)
PROJ.CATEGORY	<u>INTEGRATED MOBILITY DIVISION.</u>			\$1,348,000	
PUBLIC TRANS					

TU-0011	NCDOT, NCDOT-IMD SECTION 5304 PROGRAM FUNDS	PLANNING	FY 2024 -	\$1,700,000	(5303)
STATEWIDE	TO SUPPORT THE INTEGRATED MOBILITY DIVISION	ADMINISTRATIVE	FY 2023 -	<u>\$370,000</u>	(5303)
PROJ.CATEGORY	URBAN TRANSIT TECHNICAL ASSISTANCE ACTIVITIES.			\$2,070,000	
PUBLIC TRANS	<u>MODIFY FUNDING IN FY 24 AT THE REQUEST OF THE</u>				
	<u>INTEGRATED MOBILITY DIVISION.</u>				

TU-0016	LINK TRANSIT, PLANNING FOR TRANSIT SYSTEM	PLANNING	FY 2023 -	\$600,000	(L)
STATEWIDE	MANAGEMENT.		FY 2023 -	\$2,400,000	(5307)
PROJ.CATEGORY	<u>MODIFY FUNDING IN FY 23, FY 24 AT THE REQUEST OF</u>		FY 2024 -	\$250,000	(L)
PUBLIC TRANS	<u>THE INTEGRATED MOBILITY DIVISION.</u>		FY 2024 -	\$1,000,000	(5307)
			FY 2025 -	\$45,000	(L)
			FY 2025 -	\$185,000	(5307)
			FY 2026 -	\$45,000	(L)
			FY 2026 -	\$185,000	(5307)
			FY 2027 -	\$45,000	(L)
			FY 2027 -	\$185,000	(5307)
			FY 2028 -	\$45,000	(L)
			FY 2028 -	<u>\$185,000</u>	(5307)
				\$5,170,000	

* INDICATES FEDERAL AMENDMENT

**REVISIONS TO THE 2020-2029 STIP
HIGHWAY PROGRAM
STIP DELETIONS**

DIVISION 7

* EL-4828B ORANGE PROJ.CATEGORY EXEMPT	MORGAN CREEK GREENWAY, PHASE 2 - WEST OF MORGAN CREEK TO PIEDMONT EMC UTILITY EASEMENT IN CARRBORO. CONSTRUCT GREENWAY AND CONNECTIONS.	RIGHT-OF-WAY CONSTRUCTION	FY 2023 - \$623,000 (TADA) FY 2023 - \$550,000 (L) FY 2024 - \$647,000 (BGDA) FY 2024 - <u>\$550,000</u> (L)
	<u>DELETE PROJECT AT THE REQUEST OF MPO. INCORRECT STIP NUMBER WAS PREVIOUSLY USED.</u>		\$2,370,000

DIVISION 10

HS-2010I UNION PROJ.CATEGORY REGIONAL	NC 16 (PROVIDENCE ROAD), SR 1307 (BONDS GROVE CHURCH ROAD) INTERSECTION NEAR MARVIN. WIDEN ROAD, ADD TURN LANE, AND INSTALL TRAFFIC SIGNAL.	RIGHT-OF-WAY UTILITIES CONSTRUCTION	FY 2024 - \$120,000 (HSIP) FY 2024 - \$120,000 (HSIP) FY 2025 - \$495,000 (HSIP) FY 2026 - <u>\$364,000</u> (HSIP)
	<u>DELETE PROJECT AT THE REQUEST OF THE DIVISION. WORK TO BE ACCOMPLISHED UNDER U-5769AA.</u>		\$1,099,000

ITEM N SUMMARY

ADDITION	30	PROJECTS	\$118,957,000
MODIFICATION	90	PROJECTS	
DELETION	2	PROJECTS	\$3,469,000
	122	PROJECTS	\$115,488,000

* INDICATES FEDERAL AMENDMENT

May 4, 2023
Board of Transportation Agenda – Special and Municipal Agreements

SUMMARY: There are a total of 39 agreements for approval by the Board of Transportation.

Division 1

Chowan University
Hertford County
36249.4627
1000017476

This Project consists of the installation of four pedestrian activated crosswalk flasher systems. The Department will install the flasher systems. The University shall be responsible for 100% of the cost of work. The estimated cost of the Project is \$60,000.

Elizabeth City State University
(Middle School Program)
Pasquotank County
50084.1.49
11469

This Project is to provide a National Summer Transportation Institute curriculum targeted for middle school students related to transportation career opportunities. The Department shall reimburse the University 100% of the approved eligible costs up to the maximum federal and state award amount of \$61,800.

Division 3

Town of Wrightsville Beach
New Hanover County
BL-0075
50708.3.1
1000018225

This Project consists of resurfacing and restriping a portion of US 76 (Causeway Drive) to include 5 vehicle lanes and bike lanes on either side. The Project also consists of the installation of crosswalks across Old Causeway Drive at US 76 and Old Causeway Drive at Keel Street. The Department will use STBGDA funding for 80% of costs, or \$269,245. The Municipality shall provide 20% of costs, or \$67,312. This shall be the Municipality's full and complete share of the costs of the Project. The Department will fund any costs that exceed the estimated cost of the \$336,557.

New Hanover County
W-5703C
44849.2.10
44849.3.20
1000016940
1000016941

This Project consists of road improvements to US 421 (Carolina Beach Road) in New Hanover County. At the request of the County the Department shall acquire the right of way and construct a 5' sidewalk and 10' multi-use path along the Project. The estimated cost of the additional work is \$577,437. The County has obtained \$461,789 in STBG-DA funding from the Wilmington MPO to cover 80% of the estimated costs and will provide the 20% non-federal match of 115,488 and all costs that exceed the total available funding for the improvements of \$577,437.

Town of Wallace
Duplin County
42894
RAIL

This Agreement covers the removal of crossing signal equipment, which includes 2 signal poles with cantilever, all attached signals and signs, and 1 signal equipment cabinet from the inactive at-grade crossing located at East Main Street (Crossing 628 653P) on the W&W Rail Corridor. The Department will perform the work. The estimated cost to the Department is \$20,000.

May 4, 2023

May 4, 2023
Board of Transportation Agenda – Special and Municipal Agreements

Division 4, cont.

County of Halifax
(Halifax/Assignor)
JBB Packaging LLC
(Industry/Assignee)
Halifax County
80000.3.1.19
RAIL

On November 19, 2019, the Department, County of Halifax, and JBB Packaging entered into a Rail Industrial Access Agreement (RIAA) to rehabilitate and realign an existing rail spur off the CSX SA-line at approximately MP 80.30 to serve the Industry. This Assignment and Assumption Agreement is an acknowledgement and approval by the Department of the RIAA transfer of the contingent interest liability from Halifax to the Industry. The terms and conditions of the RIAA will remain the same with the Industry assuming, covenanting, and agreeing to keep and fulfill all terms and conditions. There is no cost to the Department for this Agreement.

Division 5

Vance Granville Community
College
Vance County
50084.1.52
11470

This Project is to provide a National Summer Transportation Institute curriculum targeted for high school and middle school students related to transportation career opportunities. The Department shall reimburse the University 100% of the approved eligible costs up to the maximum federal and state award amount of \$33,049.

City of Durham
Durham County
5B.203214.6
1000018352

This Project consists of the design and construction of a pipe replacement on Pope Road in Durham. The Municipality shall be 100% responsible for the total cost of work. The estimated cost of the Project is \$36,509.21.

Division 6

Town of Elizabethtown
Bladen County
36248.205
1000017836

This Agreement is for reimbursement to the Department for work performed in the Town of Elizabethtown. Under the provision of G.S. 136-41.1, the Department is authorized to use Powell Bill funds allocated to a municipality when the municipality fails to pay. The reimbursement due is \$925,000.

UNC Pembroke
Robeson County
50084.1.51
11472

This Project is to provide a National Summer Transportation Institute curriculum targeted for high school and middle school students related to transportation career opportunities. The Department shall reimburse the University 100% of the approved eligible costs up to the maximum federal and state award amount of \$45,807.

May 4, 2023
Board of Transportation Agenda – Special and Municipal Agreements

Division 7

NC A&T State University
Guilford County
50084.1.50
11471

This Project is to provide a National Summer Transportation Institute curriculum targeted for high school and middle school students related to transportation career opportunities. The Department shall reimburse the University 100% of the approved eligible costs up to the maximum federal and state award amount of \$61,791.

City of Greensboro
Guilford County
U-5532I
46297.1.11
46297.2.11
46297.3.11
11473

This Project is for the construction of sidewalks in various locations in Greensboro. This Supplemental Agreement is to add the preliminary engineering (PE) phase to the project as an eligible, reimbursable phase. There is no additional funding associated with this Agreement.

City of Reidsville
Rockingham County
BR-0041
67041.3.1
1000018124

This Project consists of replacing bridge #780001 on SR 2817 (Barnes Street) over US 29 in Rockingham County. At the request of the Municipality the Department will install sidewalk and curb ramps, and a bridge modification with the Reidsville Logo. The Municipality shall participate in 30% of the total sidewalk cost and 100% of the bridge betterment. The estimated total cost of the Project is 123,440.

Division 8

Town of Pittsboro
Chatham County
50552
11402

The Project consists of placing existing overhead utility lines underground along US 15-501 between two entrances accessing Chatham Park at SR 1658 (Russet Run Road) and Mosaic Drive and installing pedestrian signals, crosswalks, and signage at the intersections of US 15/501 and SR 1599 (Northwood School Road)/SR 1658 (Russet Run Road) and US 15/501 and Charger Boulevard/Mosaic Drive. The Municipality will perform the work. The Department will participate in the actual construction costs up to a maximum of \$1,200,000. The estimated total cost of the Project is \$1,685,145.

May 4, 2023
Board of Transportation Agenda – Special and Municipal Agreements

Division 8, cont.

Town of Southern Pines
Moore County
R-5788HL
44918.3.28
1000018056

This Project consists of upgrading pedestrian curb ramps to ADA standards in Sanford. The Department shall perform the work. The Department will use TAP funding for 80% of the costs of the work. The Municipality will provide the 20% non-federal match. The estimated cost of the Project is \$105,564.25. The estimated share from the Municipality is \$21,112.85

Town of Aberdeen
Moore County
EB-5741
51064.1.1
51064.3.1
1000017971
1000017972

This Project consists of the design and construction of mid-block crosswalk, median refuge island, and pedestrian signal on US 1/US 15/501 (Sandhills Boulevard) south of Maple Avenue in Aberdeen. The Department will use TAP funding for 80% of the costs of the design work. The estimated cost of the design work is \$19,500. The estimated share from the Municipality is \$3,900. The estimated cost of the construction costs is \$260,500. The estimated share from the Municipality is \$52,100.

Town of Pittsboro
Chatham County
R-5788HK
44918.3.27
1000018054

This Project consists of upgrading pedestrian curb ramps to ADA standards in Pittsboro. The Department shall perform the work. The Department will use TAP funding for 80% of the costs of the work. The Municipality will provide the 20% non-federal match. The estimated cost of the Project is \$9,171.25. The estimated share from the Municipality is \$1,834.25

Division 9

City of Winston-Salem
Forsyth County
U-2729
34853.3.3
1000017885

The Project consists of widening SR 1672 (Hanes Mill Road) to multi-lanes with curb and gutter installation from Museum Drive to SR 4000 (University Parkway). At the request of the Municipality the Department will relocate the water and sewer lines. The Municipality shall reimburse the Department 100% of the actual work. The estimated cost of the Project is \$502,191.84.

City of Winston-Salem
Forsyth County
U-2729
34853.3.3
1000017863

The Project consists of widening the SR 1672 (Hanes Mill Road) to multi-lanes with curb and gutter installation from Museum Drive to SR 4000 (University Parkway). At the request of the Municipality the Department shall install a sidewalk and interchange lighting. The Municipality shall be responsible for 50% of the actual sidewalk construction costs. The Department will pay for 100% of the interchange lighting. The estimated cost of the Project is \$310,721.

May 4, 2023

May 4, 2023
Board of Transportation Agenda – Special and Municipal Agreements

Division 9, cont.

North Carolina Railroad
Company (Company)
Norfolk Southern Railroad
Company (Railroad)
Davidson County
B-5783
45738
RAIL

This Construction and Reimbursement Agreement provides for the construction for replacement of US 29/US 70 Overhead Bridges over the Company tracks, near Company Sta. 21+53.61 (Bridge No. 168, Crossing No. 722 329F) and Sta. 21+13.32 (Bridge No. 164, Crossing No. 942 922S), respectively, in accordance with plans and specifications prepared by the Department to be reviewed and approved by the Company and the Railroad. The Department will perform the work. The total estimated cost to the Department is \$5,777,000.

Forest Abbey Homeowners
Association
Rowan County
2022CPT.09.14.20802
1000018268

This Project consists of asphalt surface treatment of 53 sections of secondary roads in Rowan County. At the request of the Forest Abbey HOA, the work will include brooming and fog seal of SR-2907 Forest Abbey, SR-2908 MacKenzie Court, and SR-2909 Constance Court. The HOA shall be responsible for 100% of the costs of betterments. The estimated cost of the Project is \$6,910.

Division 10

Mecklenburg County
EB-5829
45969.3.1
1000018210

This Project consists of the construction of Four Mile Creek Greenway Crossing under SR 3448 (South Trade Street). The Department is constructing the Department and the County is participating with Federal STBG-DA funds and non-federal match. This supplemental agreement is to provide an additional \$344,000 (80%) for the construction phase. The County shall provide the 20 % non-federal match of \$86,000 and additional local overmatch funding of \$29,000 for a total of \$115,000. The County shall pay all costs that exceed the total available funding of \$3,040,800.

Union County
U-5808
44381.3.1
1000018260

The Project consists of improvements for Chestnut Lane Connector. At the request of the County the Department will relocate the water and sewer facilities. The County shall reimburse the Department an estimated cost of \$516,970.88. The estimated cost of the Project is \$885,847.47.

Town of Marshville
Union County
BL-0011
49486.1.1
49486.3.1
1000017875
1000017876

The Project consists of the construction of pedestrian improvements at SR 1735 (East Union Street) from SR 1719 (Olive Branch Road) to Park Drive. The Department will perform the work. The Department will use STBGDA funding allocated by the MPO for 80% of the costs of the Project, or \$318,000. The Municipality shall provide 20% of the costs, or \$79,500 and all cost that exceed the total estimated cost of \$397,500.

May 4, 2023

May 4, 2023
Board of Transportation Agenda – Special and Municipal Agreements

Division 10, cont.

Greyhound Lines, Inc.
Mecklenburg County
RAIL

The Department and Company entered into an Agreement on August 23, 2018, for the lease of a certain 1.34-acre parcel of property located at 601 West Trade Street, in Charlotte, North Carolina. The property is used solely for the purpose of serving as the base of operations for Tenant's intercity bus service. Said lease was for a six (6) year period. This Amendment extends the term of the Original Lease with the term commencing August 2023 and terminating August 2024 with no renewal option. All remaining terms and conditions of the Original Lease shall continue in full force and effect, and the lease fee is \$1.00 per year.

Pulte Home Company, LLC
Cabarrus County
M-0549E
49495
RAIL

This Crossing Improvement Construction Reimbursement Agreement provides for reimbursement to the Department from the Developer for all costs by Norfolk Southern Railway for the at-grade crossing improvement and the addition of sidewalks at Norfolk Southern Railway tracks and SR 1304 - Roberta Road (Crossing 736 256N, MP 360.85) in conjunction with the Developer Project. Reimbursement shall be for 100% of the Department's costs to coordinate the construction with Norfolk Southern Railway. The total estimated cost to the Developer is \$197,850. There will be no cost to the Department for this Agreement.

Morris-Berg Architects, Inc.
Mecklenburg County
P-5719
46931
RAIL

This Agreement covers the 30% design services for Phase 2 of the Charlotte Maintenance Facility (LRMF) for the servicing, maintenance, and repair of intercity passenger rail equipment. The LRMF Phase 2 project supports Federal Railroad Administration funding for new passenger rail equipment and related infrastructure. The Department will contribute state-matching funds to the project as programmed in the FY 2023 to FY 2025 STIP. The total estimated cost to the Department is \$4,000,000.

New Atlantic Contracting, Inc.
Mecklenburg County
P-5719
46931
RAIL

This Agreement covers the Construction Manager at Risk 30% preconstruction services for Phase 2 of the Charlotte Maintenance Facility (LRMF) for the servicing, maintenance, and repair of intercity passenger rail equipment. The LRMF Phase 2 project supports Federal Railroad Administration funding for new passenger rail equipment and related infrastructure. The Department will contribute state-matching funds to the project as programmed in the FY 2023 to FY 2025 STIP. The total estimated cost to the Department is \$400,000.

May 4, 2023

May 4, 2023
Board of Transportation Agenda – Special and Municipal Agreements

Division 10, cont.

National Railroad Passenger Corporation (Amtrak)
Mecklenburg County
P-5719
46931
RAIL

This Agreement provides for the development of Schematic Design plans representing at least 30% design of the Charlotte Maintenance Facility (LRMF) to be constructed in the City of Charlotte for the servicing, maintenance, and repair of Amtrak's intercity passenger rail equipment in accordance with plans and specifications prepared by the Department to be reviewed and approved by Amtrak. Amtrak will reimburse the Department 100% of the project costs. The Department will contribute state-matching funds to the project as programmed in the FY 2023 to FY 2025 STIP. The total estimated cost to the Department is \$5,000,000.

Union County
HL-0116
50824.1.1
50824.2.1
50824.3.1
1000017695
1000017696
1000017697

This Project consists of road improvements at Bonds Grove Church Road and Waxhaw Marvin Road in Union County. The Department will deliver the Project on behalf of the County. The County has been awarded STBGDA funding for 80% of the estimated cost and will be responsible for the 20% non-federal match of \$1,092,000 and all costs that exceed the total estimated cost of \$5,460,000 for the design, right of way, and construction phases.

Division 11

Town of Wilkesboro
Wilkes County
U-5312
45446.3.1
1000018206

This Project consists of roadway improvements along US 421/NC 16. At the request of the Municipality the Department will relocate the water and sewer lines. The Municipality shall reimburse the Department 100% of the actual cost of the work. The estimated cost of the Project is \$1,458,255.

May 4, 2023
Board of Transportation Agenda – Special and Municipal Agreements

Division 12

Freshwater Landing
Development Partners, LLC
(Developer)
Iredell County
M-0549I
49495
RAIL

This Preliminary Engineering Reimbursement Agreement provides reimbursement to the Department from the Developer for all costs associated with preliminary engineering coordination and design review of construction-level design plans for the location of the new development, which will require the widening and improvement of the at-grade crossing of SR 1106 - Bridges Farm Road (Crossing 721 704A, MP O-23.18) with signals and the conversion of a private at-grade crossing (Crossing 721 703T, MP O-23.41) to a gated and locked emergency access with surface improvements and geometry rework in conjunction with the Developer Project. The Developer is responsible for the development of construction-level design plans showing the overall layout and impacts being proposed to SR 1106 - Bridges Farm Road and the private at-grade crossing (Crossing 721 703T, MP O-23.41). Reimbursement shall be for 100% of the Department's costs to coordinate preliminary engineering review by Norfolk Southern Railway. The total estimated cost to the Developer is \$65,000. There will be no cost to the Department for this Agreement.

City of Shelby
Cleveland County
R-2707D
34497.3.12
1000017554

This Project consists of road improvements on US 74 (Shelby Bypass) from east of NC 150 to existing US 74 west of SR 2238 (Long Branch Road). At the request of the Municipality the Department will relocate the water lines. The Municipality shall reimburse the Department 100% of the actual cost of the work. The estimated cost of the work is \$19,250.

City of Shelby
Cleveland County
U-5775
50186.3.1
1000018367

This Project consists of an intersection realignment at US 74 Business (Marion Street) and NC 150 (Cherryville Road). At the request of the Municipality the Department will construct and install a waterline betterment. The Municipality is responsible for 100% of the total cost of the additional work. The estimated cost of the additional work is \$373,040.

Division 14

City of Hendersonville
Henderson County
EB-5860
47316.1.1
1000017648
May 4, 2023

This Project consists of the design of a multiuse path on Blythe Street between US 64 and NC 191. The Department will perform the work. The Municipality shall reimburse the Department for 20% of the design work. The estimated cost of the Project is \$216,000.

May 4, 2023
Board of Transportation Agenda – Special and Municipal Agreements

Division 14, cont.

Haywood County
36249.4618
1000017139

This Project consists of increasing lane width and adding paved shoulders on NC 110. The Department will perform the work. The County shall be responsible for all costs that exceed \$1,900,000. The County and the Department have the option to reject any bids that exceed \$1,900,000.

FLAP agreement
Transylvania County
R-5865
47628.1.1
47628.3.1
11477

This Project consists of widening and installing turn lanes on 276 from US 64 to Avery Creek Trail Head in Transylvania County. The Department shall utilize \$2,770,000 in federal FLAP funding and provide a 20% (\$680,000) state match. The estimated cost of the project is \$3,450,000. The purpose of this amendment is to modify the agreement to combine NC FLAP DOT 276(1) with NC 63, and to shift the approved funding from preliminary engineering (PE) and construction (CN) to all preliminary engineering (PE). If there are remaining FLAP funds after the completion of preliminary engineering, the remaining FLAP funding may be used on additional project phases, including construction.

City of Brevard
Transylvania County
R-5799
44984.3.1
1000017833

The Project consists of construction improvements at the intersections of US 64 and US 276 and US 64 and NC 280. At the request of the Municipality, the Department will construct sidewalks at the intersection of US 64 and NC 280. The Municipality shall reimburse the Department 20% of actual project costs. The estimated participation by the Municipality is \$40,410. The estimated cost of the Project is \$202,050.

May 4, 2023
Board of Transportation Agenda – Special and Municipal Agreements

SUMMARY: There are a total of 24 agreements for informational purposes only.

Division 1

Dare County
36249.4632
1000017543

This Project consists of the review and inspection of a signal modification to add an emergency vehicle preemption. The Department will review the traffic signal plans and inspect the traffic emergency preemption installation. The County shall reimburse the Department 100% for the work. The estimated total reimbursement is \$5,000.

Division 2

Town of Emerald Isle
Craven County
2RE.101615
11447

The Project consists of the Municipality perform or provide routine and/or clean up mowing of the State maintained roadways within the corporate limits of the Municipality. The Municipality shall provide the equipment, labor, materials and traffic controls to perform the mowing. The Department shall participate in the costs of the work in an amount not to exceed \$7,703.94.

Town of Cape Carteret
Carteret County
11468

This Agreement is to allow Disaster Related Debris Removal by the Municipality during a State or Disaster or Imminent Threat of Disaster and/or a State Emergency. The Municipality shall remove and dispose of disaster related debris on all released State Routes. The Municipality shall apply directly to FEMA for reimbursement of eligible debris removal costs.

Division 3

Town of Wallace
Duplin County
RAIL

This agreement transfers ownership of 2 signal poles with cantilever, all attached signals and signs and 1 signal equipment cabinet, from the NC Department of Transportation Rail Division to the Town of Wallace (Employer Identification Number 56-6001361), pursuant to N.C. Session Law 2021-180. This ownership transfer is at no cost to the Department or the Town of Wallace.

Westgate Townes, LLC
Brunswick County
36249.4658
1000017847

The Project consists of a signal review and inspection for signal modification at US 17 (Ocean Highway) and Ocean Gate Plaza North U-turn [03-0971] related to the West Gate Townhomes development. The Department will review the traffic signal plans and inspect the traffic signal installation. The Developer shall reimburse the Department 100% for the work. The estimated total reimbursement is \$5,000.

May 4, 2023

May 4, 2023
Board of Transportation Agenda – Special and Municipal Agreements

Division 3, cont.

Hawthorne at Headwaters, LLC
Pender County
36249.4660
1000017886

The Project consists of a signal review and inspection for signal installation and modifications along US 17 & the development driveway / road and SR 1582 (Washington Acres Road) and signal coordination work to be performed by NCDOT required along US 17 related to the Headwaters Apartments development. The Department will review the traffic signal plans and inspect the traffic signal installation. The Developer shall reimburse the Department 100% for the work. The estimated total reimbursement is \$10,000.

Division 5

Fifth Oak Development LLC
Wake County
36249.4653
1000017872

This Project consists of a modification of an existing signal at the intersection of Buffalo Road and Forestville Road in response to a road widening, and a new signal at the intersection of Buffalo Road and New Site Driveway of new development. The Department will review the traffic signal plans and inspect the traffic signal installation. The Developer shall reimburse the Department 100% for the work. The estimated total reimbursement is \$7,000.

Lennar Carolinas LLC
Durham County
36249.4654
1000017873

This project will install a new traffic signal at the intersection of S. Mineral Springs Road at Pleasant Drive as part of the Mica Ridge development in Durham, NC. The Department will review the traffic signal plans and inspect the traffic signal installation. The Developer shall reimburse the Department 100% for the work. The estimated total reimbursement is \$5,000.

Lennar Carolinas, LLC
Durham County
36249.4652
1000017853

This Project consists of the installation of a right turn lane along South Mineral Springs Road, restriping into dual right turns along with a single through-right turn and the installation of pedestrian equipment and crosswalks at South Mineral Springs Road. The Department will review the traffic signal plans and inspect the traffic signal installation. The Developer shall reimburse the Department 100% for the work. The estimated total reimbursement is \$5,000.

May 4, 2023
Board of Transportation Agenda – Special and Municipal Agreements

Division 5, cont.

KS Bank, Inc.
Wake County
36249.4662
1000017913

The Project consists of a signal modification in response to a lane widening that will impact an existing traffic signal pole and pedestrian pedestals at the intersection of Vandora Springs Road and Seventh Avenue. The Department will review the traffic signal plans and inspect the traffic signal installation. The Developer shall reimburse the Department 100% for the work. The estimated total reimbursement is \$5,000.

Town of Holly Springs
Wake County
U-6094
47899.2.1
47899.3.1
11461

This Project consists of widening Holly Springs Road. This Supplemental agreement is to allow the Municipality additional time to complete the Project. The new completion date is 8/31/2026 in lieu of 10/24/2024.

Town of Cary
Wake County
36249.4663
1000017929

This Project consists of a review and oversight of the construction of the Higgins Greenway phase IV along Kildaire Farm Road. The Department will review and approve the planning, environmental document, and design phases of the Project. The estimated reimbursement from the Municipality is \$10,000.

Town of Apex
Wake County
36249.4666
1000017978

The Project consists of a review and oversight of the construction of the construction of a sidewalk along the south side of Saunders Street and a sidewalk along the west side of Hinton Street. The Department will review and approve the planning, environmental document, and design phases of the Project. The estimated reimbursement from the Municipality is \$10,000.

City of Durham
Durham County
C-5605H
43725.1.7
43725.3.9
11465

This Project consists of installing wayfinding signage in downtown Durham. This Supplemental agreement is to allow the Municipality additional time to complete the Project. The new completion date is 4/30/2027 in lieu of 4/3/2023.

May 4, 2023
Board of Transportation Agenda – Special and Municipal Agreements

Division 5, cont.

Tri Pointe Homes, Inc.
Wake County
36249.4667
1000018110

The Project consists of installing a temporary signal at Louis Stephens Drive to a new development in Wake County. The Department will review the temporary traffic signal plans and inspect the traffic signal installation. The Developer shall reimburse the Department 100% for the work. The estimated total reimbursement is \$5,000.

Town of Apex
Wake County
U-5537
44112.1.F1
44112.2.1
44112.3.1
11474

This Project consists of widening Lake Pine Drive to three lanes. This Supplemental Agreement is to allow the Municipality additional time to complete the Project. The completion date for this Project is 12/31/2024 in lieu of 6/30/2023.

Division 6

Town of Hope Mills
Cumberland County
U-4709
39073.3.1
11431

This Project consists of the widening road SR 1112 (Rockfish Road) to four lanes from SR 1115 (Golfview Road) to NC 59 (Main Street). At the request of the Municipality the Department shall construct a sidewalk within the limits of the Project. Upon completion of the sidewalk the Municipality shall assume maintenance responsibility.

Town of Hope Mills
Cumberland County
HL-0036
49660.1.1
49660.3.1
11467

This Project consists of the construction of a multi-use path along NC 59. This supplemental agreement clarifies the scope of the project by approval of the FAMPO.

Division 7

Elon University
Alamance County
36249.4665
1000018015

The Project consists of a signal upgrade to existing SN #07-1869 at the intersection of North O’Kelly Avenue and NC 100 (University Drive). The Department will review the traffic signal plans and inspect the traffic signal installation. The University shall reimburse the Department 100% for the work. The estimated total reimbursement is \$5,000.

May 4, 2023
Board of Transportation Agenda – Special and Municipal Agreements

Division 9

Town of Bermuda Run
Davie County
I-0911A(L)
34147.3.5
11458

The Project consists of road improvements from NC 801 to SR 1122 (Summerset Drive) in Bermuda Run. At the request of the Municipality, the Department will design landscaping features, install plantings, and provide maintenance of the new landscaping features and aesthetic improvements.

Village of Clemmons
Forsyth County
I-0911A(L)
34147.3.5
11459

The Project consists of road improvements from NC 801 to SR 1122 (Summerset Drive) in Clemmons. At the request of the Municipality, the Department will design landscaping features, install plantings, and provide maintenance of the new landscaping features and aesthetic improvements

Division 12

Cambridge-Harris Farms, LLC
Iredell County
36249.4622
1000017356

This Project consists of modifying an existing traffic signal #12-1799 at the intersection of NC-3 (Coddle Creek Hwy) and SR 1148 (Kristler Farm Road). The Department will review the traffic signal plans and inspect the traffic signal installation. The Developer shall reimburse the Department 100% for the work. The estimated total reimbursement is \$5,000.

Bradshaw Holdings Group, LLC
Catawba County
36249.4664
1000018047

This Project consists of a modification of one existing traffic signal #12-0307 at the intersection of SR 1007 (Lenoir Rhyne Blvd) and SR 1457 (9th Avenue SE). The Department will review the traffic signal plans and inspect the traffic signal installation. The Developer shall reimburse the Department 100% for the work. The estimated total reimbursement is \$5,000.

Division 13

Sheetz, Inc.
Burke County
36249.4661
1000017897

The Project consists of a signal modification at intersection of US 70 (Carbon City Rd) at SR 1304 (Independence Blvd.)/SR 1142 (Jamestown Road) in Burke County. The Department will review the traffic signal plans and inspect the traffic signal installation. The Developer shall reimburse the Department 100% for the work. The estimated total reimbursement is \$5,000.

NCDOT May 2023 Board of Transportation Agenda

Municipal Street System Changes for the Powell Bill Program

Deletions from the State Highway System

Division	County	Municipality	Road	Termini	Length
2	Carteret	Beaufort	SR 1493; Cedar Street	From SR 1174 (Turner Street) to SR 1493 (Live Oak Street)	0.41
File Name: CARTERET_2023_05_M001					
10	Cabarrus	Concord	SR 2506; Old Farm Road SE	From SR 2635 (Old Airport Road) to SR 2636 (Heglar Road)	0.49
File Name: CABARRUS_2023_05_M001					
5	Wake	Cary	SR 1610; Lewey Drive	From NC 55 to Park York Lane	0.39
5	Wake	Cary	SR 2993; Cary Oaks Drive	From SR 1152 (Holly Springs Road) to End of Maintenance	0.13
5	Wake	Cary	SR 2994; Holly Stream Court	From SR 2993 (Cary Oaks Drive) to End of Maintenance	0.05
5	Wake	Cary	SR 4016; Holly Brook Drive	From SR 1300 (Kildaire Farm Road) to End of Maintenance	0.73
5	Wake	Cary	SR 4017; Brook Cross Drive	From SR 4016 (Holly Brook Drive) to Chandler Cove Way	0.17
5	Wake	Cary	SR 4018; Inkberry Court	From 0.03 miles northwest of SR 4016 (Holly Brook Drive) to 0.04 miles southeast of SR 4016 (Holly Brook Drive)	0.07
5	Wake	Cary	SR 4710; Coralberry Circle	From SR 4016 (Holly Brook Drive) to SR 4016 (Holly Brook Drive)	0.17
File Name: WAKE_2023_05_M001					

Total Miles = 2.61

NCDOT May 2023 Board of Transportation Agenda

Municipal Street System Changes for the Powell Bill Program

Correction to the State Highway System (retroactive to April 6, 2023)

Division	County	Municipality	Road	Termini	Length
5	Wake	Cary	(Correction to the originally listed route from SR 3036 to SR 3136) SR 3136; Twyla Road North (Stub)	From SR 3068 (Twyla Road North) Southward for 0.07 miles at current end of maintenance	0.07

File Name: WAKE_2023_04_M002

Total Miles = 0.07

May 2023 Board of Transportation Agenda

<u>No.</u>		<u>Page No.</u>
1	Preliminary Right of Way Plans	R-1 – R-2
2	Final Right of Way Plans	R-3 – R-6
3	Final Right of Way Plans Revisions	R-7
4	Conveyance ROW Residue by Real Estate Agent and/or Auctioneer	R-8 – R-10
5	Approval of Conveyance of Highway Right of Way Residues by Division	R-11
6	Approval of Revisions in Control of Access	R-12
7	Approval of Advance Acquisition of Highway Right of Way – Approval of settlement	R-13

NCDOT May 2023 Board of Transportation Agenda

Preliminary Right of Way Plans

The Preliminary Right of Way Plans for the below projects, including Secondary Roads and Industrial Access Roads, provide for the construction, design, drainage, and control of access as shown on the respective plans.

Based upon the recommendations of the Manager of the Right of Way Unit, the Board finds that such rights of way as shown on these preliminary plans and drawings, including existing public dedicated right of way, are for a public use and are necessary for the construction of said projects.

The rights of way for the location, construction, relocation, and control of access of highways embraced in the below projects shall be as shown in detail on the preliminary right of ways plans and drawings for said projects on file in the Right of Way Unit in the Department of Transportation in Raleigh.

The Board finds such right of way acquisition to be necessary and hereby authorizes the Right of Way Unit to acquire right of way on the below projects either by negotiation or by condemnation through the Attorney General's Office.

(Division 1)

Perquimans County; I.D. No. BP1.R007; Project No. BP1.R007.2:

Replace Bridge #36 on SR 1301 Old Neck Rd over Br. of Perquimans River.

(Division 2)

Pitt County; I.D. No. SS-6002Z; Project No. . 49515.2.1:

Re-align NC 903 at SR 1125 Pocosin Rd. and SR 2106 Red Forbes Rd. to form a crossroads intersection and install an all-way stop.

(Division 3)

Sampson County; I.D. No. BP3.R006; Project No. BP3.R006.2:

Bridge # 85 over Great Coharie overflow on SR 1214 Boykin Bridge Rd.

(Division 4)

Edgecombe County; I.D. No. BP4-R023; Project No. BP4.R023.2:

Replace Bridge No. 320096 on SR 1112 over Bynum Mill Run.

Johnston County; I.D. No. BR-0086; Project No. 67086.2.1:

Replace Bridge 70 on US 301 over Neuse River.

(Division 10)

Anson County; I.D. No. BP10.R-033; Project No. BP10.R033.2

Replace Bridge No. 030231 over Cabin Branch on SR 1637 (Jacks Branch Rd.)

NCDOT May 2023 Board of Transportation Agenda

Preliminary Right of Way Plans-cont.

(Division 10)-cont.

Cabarrus County; I.D. No. BP10.R0047; Project No. BP10.R0047.2
Replace Bridge No. 120083 over Dutch Buffalo Creek on SR 2408 Gold Hill Rd.

Stanly County; I.D. No. BP10.R050; Project No. BP10.R050.2
Bridge # 208 over Rocky River on SR 1001 Love Mill Rd.

Union County; I.D. No. BP10.R022; Project No. BP10.R022.2
Replace Bridge No. 0092 on SR 1903 Gilboa Rd. over Beaverdam Creek.

(Division 13)

Madison County; I.D. No. BP13-R015; Project No. BP13.R015.2:
Bridge # 98 on SR 1370 Grapevine Rd. over West Fork of Bull Creek.

Madison County; I.D. No. BP13-R014; Project No. BP13.R014.2:
Bridge # 90 on SR 1318 Big Laurel Rd. over Big Laurel Creek.

Mitchell County; I.D. No. 17BP.13.R.184; Project No. 17BP.13.R.184:
Bridge # 101 on SR 1002 Crabtree Rd. over Big Crabtree Creek.

(Division 14)

Henderson County; I.D. No. BP14.R018; Project No. BP14.R018.2:
Replace Bridge 182 over Sweet Water Branch on SR 1328 Old Turnpike Rd.

Jackson County; I.D. No. BP14.R025; Project No. BP14.R025.2:
Replace Bridge 490294 over Gage Creek on SR 1756 Charley's Creek Rd.

Polk County; I.D. No. BP14.R013; Project No. BP14.R013.2:
Replace Bridge 22 over Wolfe Creek on SR 1501 Squeak Valley Rd.

PRELIMINARY RIGHT OF WAY PLANS

15 PROJECT(S)

\$ 0.00

NCDOT May 2023 Board of Transportation Agenda

Final Right of Way Plans

Right of way acquisition in accordance with the preliminary right of way plans on file in the Right of Way Unit has been determined to be necessary for public use and was authorized by the Board. Certain changes in the right of way have necessitated alteration of the preliminary right of way plans. Final plans have been prepared and provided for the construction, design, drainage, and control of access for these projects. The Board finds that such rights of way and control of access as shown on the final plans are for a public use and are necessary for construction. The sections of roads which were shown on the preliminary plans as sections of roads to be abandoned are hereby abandoned and removed from the State Highway System for Maintenance upon the completion and acceptance of the project.

The rights of way for the location, design and construction of highways embraced in the following projects shall be as shown in detail on the final plans for said projects as follows:

(Division 3)

Project No. 67160.2.1; Brunswick County; I.D. No. BR-0160:
 Bridge #15 over Calabash River on NC 179B Beach Dr. SW.
 Drainage, grading, paving & structures. 0.313 miles total length.

(Division 4)

Project No. 47944.2.2; Nash County; I.D. No. I-6045:
 US 64 (future I-87) from SR 1306 South Old Franklin Rd. to SR 1603 Old Carriage Rd.
 Pavement rehabilitation. 9.47 miles total length.

Project No. 47990.3.1; Edgecombe County; I.D. No. I-6041:
 US 64 (future I-87) from SR 1225 Kingsboro Rd. to NC 33.
 Pavement rehabilitation. 10.18 miles total length.

Project No. 47991.3.1; Edgecombe County; I.D. No. I-6042:
 US 64 (future I-87) from NC 33 to Martin County Line.
 Pavement rehabilitation. 10.22 miles total length.

(Division 6)

Project No. 34466.3.8; Columbus County; I.D. No. R-2561CA:
 NC 87 Old Stage Rd./NC 11 General Howe Rd. interchange.
 Grading, drainage, paving & structures. 1.695 Miles total length. Partial controlled access with access being limited to points as shown on the plans.

(Division 7)

Project No. 45677.2.1; Rockingham County; I.D. No. B-5721:
 Bridge # 780124 on SR 2177 Dan Valley Rd. over the Mayo River.
 Grading, drainage, paving, & structure. 0.283 miles total length.

NCDOT May 2023 Board of Transportation Agenda

Final Right of Way Plans-cont.

(Division 9)

Project No. 45738.2.1; Davidson County; I.D. No. B-5783

Bridges # 164 and # 168 on US 29 over Norfolk Southern Railroad.

Grading, drainage, paving, & structure. 0.550 miles total length.

(Division 13)

Project No. 48063.2.1; Burke County; I.D. No. B-5869

Bridge # 99 on US 64/US 70 Fleming Dr.

Grading, drainage, paving, retaining wall & structure. 0.496 miles total length.

(Division 14)

Project No. 36049.89; Jackson County; I.D. No. N/A:

NC 281 from approximately 0.80 miles northeast of SR 1137 Bear Lake Rd./Middleton Rd. to approximately 1.03 miles northeast of SR 1137 Bear Lake Rd./Middleton Rd.

Blasting, grading, paving drainage, pavement marking, erosion control & traffic control. 0.226 miles total length.

Project No. 8.2960302; Jackson County; I.D. No. B-2051B:

Bridge # 303 on SR 1381 Hometown Place Rd. over Norfolk Southern Railroad.

Bridge removal and guardrail. 0.064 miles total length.

Project No. 45360.2.19; Jackson County; I.D. No. BD-5114S:

Bridge # 53 on SR 1001 Speedwell Rd. over Cullowhee Creek.

Grading, drainage, paving & structure. 0.142 miles total length.

Project No. 45360.2.20; Jackson County; I.D. No. BD-5114T:

Bridge # 220 on SR 1166 Parker Farm Rd. over Cullowhee Creek.

Grading, paving, drainage, & structure. 0.065 miles total length.

Project No. 17BP.14.R.129; Jackson County; I.D. No. DB14B-490182:

Bridge # 182 on SR 1747 Johns Creek Rd. over Johns Creek.

Grading, paving, drainage, and structure. 0.065 miles total length.

Project No. 40192.2.1; Jackson/Swain Counties; I.D. No. R-4758:

US 19 in downtown Cherokee 0.016 miles west of intersection of Whitewater Dr. (Old US 441) to 0.042 miles east of Campground Dr.

Realignment, slope stabilization & resurfacing. 0.365 miles total length.

Project No. 41156.2.1; Jackson County; I.D. No. R-5000:

New location connector road from NC 116 to east of NC 107.

Grading, drainage, paving & structures. 0.710 miles total length. Partially controlled access with access being limited to points as shown on the plans.

Project No. 42803.3.STI; Jackson County; I.D. No. R-5202:

NC 107 from just south of SR 1142 Laurel Knob Rd. to just north of SR 1145 North Norton Rd.

Grading, paving, drainage & culvert extension. 0.784 miles total length.

NCDOT May 2023 Board of Transportation Agenda

Final Right of Way Plans-cont.

(Division 14)-Cont.

Project No. 17BP.14.R.14; Jackson County; I.D. No. DN00147:

Bridge # 296 on SR 1120 Cedar Creek Rd. over Cedar Creek.
Grading, drainage & culvert. 0.073 miles total length.

Project No. 17BP.14.R.15; Jackson County; I.D. No. DN00148:

Bridge # 300 on SR 1371 Brushy Fork Rd. over Brushy Fork Creek.
Grading, drainage, paving & structure. 0.066 miles total length.

Project No. 17BP.14.R.16; Jackson County; I.D. No. DN00149:

Bridge # 141 on SR 1367 Little Savannah Creek Rd. over Little Savannah Creek.
Grading, paving, drainage & culvert. 0.081 miles total length.

Project No. 17BP.14.R.25; Jackson County; I.D. No. DN00158:

Bridge # 282 on SR 1307 Bettys Creek Rd. over Bettys Creek.
Grading, paving, drainage & structure. 0.114 miles total length.

Project No. 17BP.14.R.33; Jackson County; I.D. No. DN00166:

Bridge # 279 on SR 1371 Brushy Fork Rd. over Brushy Fork Creek.
Grading, paving, drainage & structure. 0.071 miles total length.

Project No. 17BP.14.R.52; Jackson County; I.D. No. DN00178:

Bridge # 251 on SR 1389 Herron Branch Rd. over Right Prong Dicks Creek.
Grading, paving, drainage & structure. 0.083 miles total length.

Project No. 17BP.14.R.62; Jackson County; I.D. No. DN00185:

Bridge # 135 on SR 1740 Moses Creek Rd. over Moses Creek.
Grading, paving, drainage, & structure. 0.076 miles total length.

Project No. 17BP.14.R.63; Jackson County; I.D. No. DN00186:

Bridge # 207 on SR 1313 East Fork Rd. over East Fork Savannah Creek.
Grading, paving, drainage, & structure. 0.099 miles total length.

Project No. 17BP.14.R.65; Jackson County; I.D. No. DN00178:

Bridge # 253 on SR 1389 Dicks Creek Rd. over Right Prong Dicks Creek.
Grading, paving, drainage, & structures. 0.076 miles total length.

Project No. 17BP.14.R.66; Jackson County; I.D. No. DN00188:

Bridge # 310 on SR 1709 Cane Creek Rd. over Cane Creek.
Grading, paving, drainage, & structure. 0.102 miles total length.

Project No. 17BP.14.R.67; Jackson County; I.D. No. DN00189:

Bridge # 322 on SR 1316 Early Dietz Rd. over E. Fork Savannah Creek.
Grading, paving, drainage, & structure. 0.051 miles total length.

Project No. 17BP.14.R.83; Jackson County; I.D. No. C202924:

Bridge # 252 on SR 1389 Herron Branch Rd. over Dicks Creek.
Grading, drainage, paving & structure. 0.080 miles total length.

NCDOT May 2023 Board of Transportation Agenda

Final Right of Way Plans-cont.

(Division 14)-Cont.

Project No. 17BP.14.R.203; Jackson County; I.D. No. DN00596:

Bridge # 490001 on SR 1119 Sapphire Post Office Rd. over Horsepasture River.

Grading, paving, drainage, & structure. 0.066 miles total length.

FINAL RIGHT OF WAY PLANS

29 PROJECT(S)

\$ 0.00

NCDOT May 2023 Board of Transportation Agenda

Revisions of the Final Right of Way Plans

Right of way acquisition in accordance with the final right of way plans for the following projects has been determined to be necessary and authorized by the Board. Plans are on file at the Office of the Secretary to the Board of Transportation as an addendum to the minutes of the meetings hereinafter indicated.

Certain changes in right of way, construction and drainage easements, and control of access have been necessitated by alterations in the construction plans of these projects. Amended plan sheets for these projects have been prepared which provide for changes of certain right of way areas, construction and drainage easements and control of access.

The Board finds that the revised areas of right of way, construction and drainage easements and control of access, as shown on the amended plan sheets hereinafter set out, are for a public purpose and are necessary for the construction of projects.

The right of way, construction and drainage easements and control of access are hereby revised as shown on the plan sheets incorporated herein as an addendum, said projects, date of original final approval, and revised right of way, easements and access being as follows:

(Division 6)

Project No. 41499.2.3; I.D. No. R-5020B; Columbus County:

Final Right of Way plans approved on the minutes of the April 8, 2021, Board of Transportation Meeting. Revised additional temporary construction easement (TCE) on plan sheet(s) 7, parcel 046 as presented at the Board of Transportation Meeting.

(Division 7)

Project No. 34840.2.4; I.D. No. U-2581BA; Guilford County:

Final Right of Way plans approved on the minutes of the October 3, 2019, Board of Transportation Meeting. Revised eliminated permanent drainage easement (PDE) and modified right of way (ROW), permanent utility easement (PUE) and temporary construction easement (TCE) on plan sheet(s) 7, parcel 043 as presented at the Board of Transportation Meeting.

(Division 12)

Project No. 34497.2.FS9; I.D. No. R-2707C; Cleveland County:

Final Right of Way plans approved on the minutes of the May 4, 2017, Board of Transportation Meeting. Revised deleted parcel 062Y and added parcel on plan sheet(s) 20A, revised property lines between parcels 060, 062Y and 062Z, as updated from the August 2022 right of way revision, on plan sheet(s) 20A; and removed parcel 062Y and revised property line between parcels 060, 062Y and 062Z as updated from the August 2022, right of way revisions plans sheet(s) 020 as presented at the Board of Transportation Meeting.

REVISIONS TO FINAL RIGHT OF WAY PLANS 3 PROJECT(S) \$ 0.00

NCDOT May 2023 Board of Transportation Agenda

Approval of conveyance of Highway Right of Way Residues by Real Estate Agent and/or Auctioneer

It is hereby resolved, based upon the recommendation of the Manager of the Right of Way Unit, that the following highway right of way conveyances are approved:

(Division 3)

Project R-2303D, Parcel 081, NC-24 From SR-1303 (Mitchell Loop Road) to US 421-701 / SR-1296 (Sunset Avenue)

Sampson County

Conveyance of an approximate 0.780-acre area comprised of one (1) B-class residue, having a value of \$3,000.00 to **Wesley Derek Watson** for the highest offer amount of **\$3,478.00**; no additional fees required. This residue was acquired for \$975.00 in 2012.

(Division 4)

Project R-2554A, Parcel 052, US-70 (Goldsboro Bypass) From West of NC-581 to SR-1300 (Salem Church Road)

Wayne County

Conveyance of an approximate 0.290-acre area comprised of one (1) B-class residue, having a value of \$2,000.00 to **Jennifer Smith Strickland** for the highest offer amount of **\$5,000.00**; no additional fees required. This residue was acquired for \$1,140.00 in 2009.

(Division 7)

Project U-2524BA, Parcel 504A, Greensboro Western Loop (Combine with I-22001G & U-2524BB) From South of I-40 to North of SR-2147 (West Friendly Avenue)

Guilford County

Conveyance of an approximate 0.500-acre area comprised of one (1) C-class residue, having a value of \$16,500.00 to **Billy R. Ratledge, Trustee Ratledge Family Trust** for the highest offer amount of **\$14,850.00**; no additional fees required. This residue was acquired for \$15,164.00 in 2000.

Project U-2524BA, Parcel 504A, Greensboro Western Loop (Combine with I-22001G & U-2524BB) From South of I-40 to North of SR-2147 (West Friendly Avenue)

Guilford County

Conveyance of an approximate 0.100-acre area comprised of one (1) C-class residue, having a value of \$2,500.00 to **Simann Brothers Holdings, LLC** for the highest offer amount of **\$2,250.00**; no additional fees required. This residue was acquired for \$3,404.00 in 2000.

NCDOT May 2023 Board of Transportation Agenda

Approval of conveyance of Highway Right of Way Residues by Real Estate Agent and/or Auctioneer-cont.

(Division 7)-cont.

Project R-2309AB, Parcel 064, Greensboro US-22 From SR-2182 (Horsepen Creek Road) to 0.2 Mile North of SR-2313 (Winfree Road) Combine with R-2413C Guilford County

Conveyance of an approximate 0.700-acre area comprised of one (1) C-class residue, having a value of \$6,500.00 to **James P. Flanigan and Kathleen A. Flanigan** for the highest offer amount of \$5,850.00; no additional fees required. This residue was acquired for \$1,350.00 in 2010.

(Division 9)

Project U-4909, Parcel 046, Winston-Salem SR-2643 (Union Cross Road) From SR-2691 (Wallburg Road) to SR-2632 (Sedge Garden Road) Forsyth County

Conveyance of an approximate 0.490-acre area comprised of one (1) B-Class residue, having a value of \$10,900.00 to **John M. Gathara** for the highest offer amount of **\$10,900.00**; no additional fees required. This residue was acquired for \$92,000.00 in 2010.

Project U-2579B, Parcel 211, Winston-Salem Northern Beltway (Eastern Section, Future I-74) From US-158 to I-40 Business / US-421 Forsyth County

Conveyance of an approximate 2.460-acre area comprised of one (1) B-Class residue, having a value of \$11,000.00 to **Randy Nelson Weavil** for the highest offer amount of **\$11,000.00**; no additional fees required. This residue was acquired for \$2,626.42 in 2013.

Project P-5206A, Parcel 006A, Peeler Grade Separation Over NCRR/NS Railroad from Reid to North of Kannapolis Rowan County

Conveyance of an approximate 0.543-acre area comprised of one (1) A-Class residue, having a value of \$20,000.00 to **Andres Lopez Islas** for the highest offer amount of **\$21,000.00**; no additional fees required. This residue was acquired for \$8,750.00 in 2014.

(Division 13)

Project A-0010D, Parcel 035, US-23 From SR-1318 (Big Laurel Road) at Laurel Creek to the Tennessee State Line at Sams Gap Madison County

Conveyance of an approximate 10.900-acre area comprised of one (1) B-class residue, having a value of \$19,440.00 to **Matthew Richard Entler** for the highest offer amount of **\$37,762.00**; no additional fees required. This residue was acquired for \$19,375.00 in 1997.

NCDOT May 2023 Board of Transportation Agenda

Approval of conveyance of Highway Right of Way Residues by Real Estate Agent and/or

Auctioneer-cont.

(Division 13)-cont.

Project A-0010C, Parcel 027A, US-23 From 0.3 Mile Northeast of US-19 to SR-1318 (Big Laurel Road) at Laurel Creek

Madison County

Conveyance of an approximate 4.350-acre area comprised of one (1) B-class residue, having a value of \$6,000.00 to **The Real Deal Homebuyers LLC** for the highest offer amount of **\$7,250.00**; no additional fees required. This residue was acquired for \$1,175 in 1996.

Project A-0010C, Parcel 058, US-23 From 0.3 Mile Northeast of US-19 to SR-1318 (Big Laurel Road) at Laurel Creek

Madison County

Conveyance of an approximate 8.440-acre area comprised of one (1) B-class residue, having a value of \$22,215.00 to **Peter Blackwell** for the highest offer amount of **\$27,600.00**; no additional fees required. This residue was acquired for \$98,750.00 in 1996.

Project A-0010C, Parcel 052, US-23 From 0.3 Mile Northeast of US-19 to SR-1318 (Big Laurel Road) at Laurel Creek

Madison County

Conveyance of an approximate 3.210-acre area comprised of one (1) B-class residue, having a value of \$11,500.00 to **Beth-Hanah, LLC** for the highest offer amount of **\$20,475.00**; no additional fees required. This residue was acquired for \$7,825.00 in 1996.

Project A-0010BB, Parcel 009, US-19/23 From .174 Mile North of NC-213 to .3 Mile Northeast of US-19 Interchange

Madison County

Conveyance of an approximate 1.500-acre area comprised of one (1) B-class residue, having a value of \$8,300.00 to **The Real Deal Homebuyers LLC** for the highest offer amount of **\$9,075.00**; no additional fees required. This residue was acquired for \$3,150.00 in 1997.

Project R-1012A, Parcel 065, US-25/70 From Tennessee State Line to 0.6 Miles West of NC-209 in Hot Springs

Madison County

Conveyance of an approximate 1.550-acre area comprised of one (1) B-class residue, having a value of \$4,650 to **The Real Deal Homebuyers LLC** for the highest offer amount of **\$4,358.00**; no additional fees required. This residue was acquired for \$310.00 in 1995.

CONVEYANCE OF HIGHWAY RIGHT OF WAY RESIDUES BY REAL ESTATE AGENT

AND/OR AUCTIONEER 14 PROJECT(S) \$ 180,848.00

NCDOT May 2023 Board of Transportation Agenda

Approval of Conveyance of Highway Right of Way Residues

It is hereby resolved, based upon the recommendation of the Manager of the Right of Way Unit, that the following highway right of way conveyances are approved:

(Division 7)

Project R-2309AB, Parcel 066,141, & 144, Greensboro US-22 From SR-2182 (Horsepen Creek Road) to 0.2 Mile North of SR-2313 (Winfree Road) Combine with R-2309AB

Guilford County

Conveyance of an approximate 1.840-acre area comprised of two (2) B-class residues and one (1) C-class residue to **The Town of Summerfield** for public use as added space to the Town's Scenic Corridor and for Public Greenway use. A reverter clause will be included in the conveyance instrument so if this 1.840-acre area is no longer needed for public purposes, the town will convey the area back to the Department at no expense to the Department. The Department acquired this residue area for \$117,475.00 between 2010 and 2011.

(Division 13)

Project U-3301, Parcel 053, NC-63 (Leicester Highway) Northwest Asheville, From SR-1615 (Gilbert Road) to West of SR-1004 (Newfound Road)

Buncombe County

Conveyance of an approximate 0.185-acre area comprised of one (1) B-class residue having a value of **\$1,200.00** to **Larry W. Ferguson and Sherry W. Ferguson** for the highest offer amount of **\$2,023.00**. The Department acquired this residue for \$925.00 in 2016.

CONVEYANCE OF HIGHWAY RIGHT OF WAY RESIDUES BY DIVISION 2 PROJECT(S)

\$2,023.00

NCDOT May 2023 Board of Transportation Agenda

Approval of Revision in Control of Access

It is hereby resolved, based upon the recommendation of the Manager of the Right of Way Unit that the following highway right of way conveyances are approved:

(Division 7)

**Project U-2412B, Parcel 021, Greensboro / High Point SR-1486/1421 (Greensboro/High Point Road) From SR-4228 (Vickrey Chapel Road) to SR-1424 (Hilltop Road) Combine with U-2524AE
Guilford County
Revision in the control of access along Gate City Boulevard to **Goodwill Industries of Central North Carolina, Inc.** for no consideration.**

APPROVAL OF REVISION IN CONTROL OF ACCESS 1 PROJECT(S) \$-0-

NCDOT May 2023 Board of Transportation Agenda

Advance Acquisition of Highway Right of Way

Upon recommendation of the Manager of the Right of Way Unit, the Board has been requested to authorize the acquisition of the following properties through negotiation or condemnation for purposes of highway construction in order to prevent undue hardship on property owners or to protect the right of way corridor from development prior to regular project approval. The Board finds such acquisitions to be necessary, and hereby authorizes the Right of Way Branch to acquire said properties either by negotiation or by condemnation through the Office of the Attorney General.

APPROVAL OF SETTLEMENT

(Division 3)

Property of Riverman LLC
 I.D. No. HB-0039, Parcel 900
 WBS 50603.2.1, F. A. Project N/A
 County of New Hanover
Settlement for \$18,142,000.00

(Division 13)

Property of Riverside Partners, LLC
 I.D. No. I-2513B, Parcel 3997
 WBS 34165.2.20, F. A. Project N/A
 County of Buncombe
Settlement for \$2,108,225.00

**APPROVAL OF ADVANCE ACQUISITION FOR HIGHWAY ROW 2 PROJECT(S)
 \$20,250,225.00**

**NORTH CAROLINA BOARD OF TRANSPORTATION
RECOMMENDED ALLOCATION OF HIGHWAY MAINTENANCE APPROPRIATIONS
FISCAL YEAR 2022 - 2023**

Thus far in Fiscal Year 2023 (FY2023), the Board has approved \$1,804,271,862 in highway maintenance allocations. An initial allocation of \$1,699,760,767 was approved on July 7, 2022 and four supplemental allocations, totaling \$104,511,095, have also been approved.

At this time, staff is requesting approval to cashflow \$48,151,000 for Bridge Program. This cashflow request is project specific. The purpose of the recommended cashflow is to better align project funding with forecasted expenditures.

The allocation summary is detailed in Table 1 on Pages S2-3.

See Page S-4 for project specific details of the cashflow request.

**NORTH CAROLINA BOARD OF TRANSPORTATION
RECOMMENDED ALLOCATION OF HIGHWAY MAINTENANCE APPROPRIATIONS
FISCAL YEAR 2022 - 2023**

Table 1 – MAINTENANCE ALLOCATION SUMMARY

<u>SCHEDULE I – GENERAL MAINTENANCE RESERVE (GMR)</u>			
<u>SCHEDULE I (a) – TRADITIONAL GMR</u>	PREVIOUS ALLOCATIONS	SUPPLEMENTAL ALLOCATION	TOTAL ALLOCATION
Cashflow Repayment	181,989,911	0	181,989,911
Cashflow from Future Years	(121,326,607)	0	(121,326,607)
<i>Cashflow Repayment Subtotal</i>	<i>60,663,304</i>	<i>0</i>	<i>60,663,304</i>
Asset Maintenance and Operations	20,628,000	0	20,628,000
Research and Development	6,284,000	0	6,284,000
State and Federal Obligation	15,875,000	0	15,875,000
<i>Enterprise Programs Subtotal</i>	<i>42,787,000</i>	<i>0</i>	<i>42,787,000</i>
Division Distribution	467,873,316	0	467,873,316
<i>Traditional GMR Total</i>	<i>\$571,323,620</i>	<i>\$0</i>	<i>\$571,323,620</i>
<u>SCHEDULE I (b) – EMERGENCY GMR</u>			
Statewide Emergency Funds	45,741,502	0	45,741,502
Division Snow and Ice Operations	34,990,499	0	34,990,499
<i>Emergency GMR Total</i>	<i>\$80,732,001</i>	<i>\$0</i>	<i>\$80,732,001</i>
<i>General Maintenance Reserve Total</i>	<i>\$652,055,621</i>	<i>\$0</i>	<i>\$652,055,621</i>
<u>SCHEDULE II – ROADSIDE ENVIRONMENTAL</u>			
	PREVIOUS ALLOCATIONS	SUPPLEMENTAL ALLOCATION	TOTAL ALLOCATION
Cashflow Repayment	13,813,029	0	13,813,029
Asset Maintenance and Operations	5,061,743	0	5,061,743
State and Federal Obligation	225,000	0	225,000
<i>Enterprise Programs Subtotal</i>	<i>5,286,743</i>	<i>0</i>	<i>5,286,743</i>
Division Distribution	99,824,850	0	99,824,850
<i>Roadside Environmental Total</i>	<i>\$118,924,622</i>	<i>\$0</i>	<i>\$118,924,622</i>

**NORTH CAROLINA BOARD OF TRANSPORTATION
RECOMMENDED ALLOCATION OF HIGHWAY MAINTENANCE APPROPRIATIONS
FISCAL YEAR 2022 - 2023**

Table 1 – MAINTENANCE ALLOCATION SUMMARY CONTINUED

<u>SCHEDULE III – CONTRACT RESURFACING</u>	PREVIOUS ALLOCATIONS	SUPPLEMENTAL ALLOCATION	TOTAL ALLOCATION
Cashflow Repayment	399,593,670	0	399,593,670
Cashflow from Future Years	(376,588,816)	0	(376,588,816)
<i>Cashflow Repayment Subtotal</i>	<i>23,004,854</i>	<i>0</i>	<i>23,004,854</i>
Asset Maintenance and Operations	13,755,019	0	13,755,019
Division Distribution	535,551,451	0	535,551,451
<i>Contract Resurfacing Total</i>	<i>\$572,311,324</i>	<i>\$0</i>	<i>\$572,311,324</i>
<u>SCHEDULE IV – PAVEMENT PRESERVATION</u>	PREVIOUS ALLOCATIONS	SUPPLEMENTAL ALLOCATION	TOTAL ALLOCATION
Cashflow Repayment	47,764,540	0	47,764,540
Cashflow from Future Years	(44,405,272)	0	(44,405,272)
<i>Cashflow Repayment Subtotal</i>	<i>3,359,268</i>	<i>0</i>	<i>3,359,268</i>
Division Distribution	82,232,514	0	82,232,514
<i>Pavement Preservation Total</i>	<i>\$85,591,782</i>	<i>\$0</i>	<i>\$85,591,782</i>
<u>SCHEDULE V – BRIDGE PROGRAM</u>	PREVIOUS ALLOCATIONS	SUPPLEMENTAL ALLOCATION	TOTAL ALLOCATION
Cashflow Repayment	27,396,483	0	27,396,483
Central Distribution	164,500,698	0	164,500,698
Division Distribution	86,816,245	0	86,816,245
Project level Cashflow from FY2024	0	26,282,000	26,282,000
Project level Cashflow from FY2025	0	19,164,000	19,164,000
Project level Cashflow from FY2026	0	2,705,000	2,705,000
<i>Bridge Program Total</i>	<i>\$278,713,426</i>	<i>\$48,151,000</i>	<i>\$326,864,426</i>
<u>SCHEDULE VI – BRIDGE PRESERVATION</u>	PREVIOUS ALLOCATIONS	SUPPLEMENTAL ALLOCATION	TOTAL ALLOCATION
Central Distribution	35,337,544	0	35,337,544
Division Distribution	35,337,543	0	35,337,543
Project level Cashflow from FY2024	18,500,000	0	18,500,000
Project level Cashflow from FY2025	7,500,000	0	7,500,000
<i>Bridge Preservation Total</i>	<i>\$96,675,087</i>	<i>\$0</i>	<i>\$96,675,087</i>
GRAND TOTAL	\$1,804,271,862	\$48,151,000	\$1,852,422,862

**NORTH CAROLINA BOARD OF TRANSPORTATION
RECOMMENDED ALLOCATION OF HIGHWAY MAINTENANCE APPROPRIATIONS
FISCAL YEAR 2022 - 2023**

SCHEDULE V – BRIDGE PROGRAM

Cashflow: At this time, staff recommends cashflowing \$48,151,000 for Bridge Program. This cashflow request is project specific. The purpose of the recommended cashflow is to align project funding with forecasted expenditures on four projects.

Cashflow detail for Schedule V – Bridge Program

<p>BR-0041 Rockingham Co. Division 7</p>	<p>WBS 67041.3.1</p> <p>Replace Bridge #1 over US 29 on SR 2817 (Barnes Street) in Rockingham County.</p> <p>Construction spending for this project is forecasted to occur over three fiscal years; therefore, the Department is requesting to cashflow funds to better align funding with forecasted expenditures. Current funding available in FY2023 will be decreased (\$13,000,000) and made available for other projects. \$8,450,000 will be cash flowed from FY2024 and \$4,550,000 will be cash flowed from FY2025.</p>
<p>BR-0043 Rockingham Co. Division 7</p>	<p>WBS 67043.3.1</p> <p>Replace Bridge #151 over US 29 on US 158 / NC 14 in Rockingham County.</p> <p>Construction spending for this project is forecasted to occur over three fiscal years; therefore, the Department is requesting to cashflow funds to better align funding with forecasted expenditures. Current funding available in FY2023 will be decreased (\$10,500,000) and made available for other projects. \$6,825,000 will be cash flowed from FY2024 and \$3,675,000 will be cash flowed from FY2025.</p>
<p>BR-0012 Cleveland Co. Division 12</p>	<p>WBS 67012.3.1</p> <p>Replace Bridge #48 and Bridge #49 over Sandy Run Creek on US 74 in Cleveland County.</p> <p>Construction spending for this project is forecasted to occur over four fiscal years; therefore, the Department is requesting to cashflow funds to better align funding with forecasted expenditures. \$103,000 should be established for FY2023 expenditures. \$5,459,000 will be cash flowed from FY2024, \$4,223,000 from FY2025, and \$515,000 from FY2026.</p>
<p>B-4926 Lenoir Co. Division 2</p>	<p>WBS 40163.3.1</p> <p>Replace Bridge #20 and Bridge #34 over Neuse River / Neuse River Overflow on NC 55 in Lenoir County.</p> <p>Construction spending for this project is forecasted to occur over four fiscal years; therefore, the Department is requesting to cashflow funds to better align funding with forecasted expenditures. \$146,000 should be established for FY2023 expenditures. \$5,548,000 will be cash flowed from FY2024, \$6,716,000 from FY2025, and \$2,190,000 from FY2026.</p>

**NORTH CAROLINA BOARD OF TRANSPORTATION
RECOMMENDED ALLOCATION OF HIGHWAY MAINTENANCE APPROPRIATIONS
FISCAL YEAR 2022 - 2023**

Table 2 – Bridge Program

Division	Previous Allocations	Supplemental Allocation	Total Allocation
1	3,774,818	0	3,774,818
2	3,872,842	0	3,872,842
3	3,837,020	0	3,837,020
4	4,521,837	0	4,521,837
5	5,441,806	0	5,441,806
6	3,281,546	0	3,281,546
7	6,603,474	0	6,603,474
8	4,493,835	0	4,493,835
9	5,392,381	0	5,392,381
10	4,850,061	0	4,850,061
11	11,044,913	0	11,044,913
12	7,228,109	0	7,228,109
13	12,849,051	0	12,849,051
14	9,624,552	0	9,624,552
Subtotal	\$86,816,245	\$0	\$86,816,245
Cashflow Repayment	27,396,483	0	27,396,483
Project Level Cashflow from FY2024	0	26,282,000	26,282,000
Project Level Cashflow from FY2025	0	19,164,000	19,164,000
Project Level Cashflow from FY2026	0	2,705,000	2,705,000
Central Distribution	164,500,698	0	164,500,698
Subtotal	\$191,897,181	\$48,151,000	\$240,048,181
Grand Total	\$278,713,426	\$48,151,000	\$326,864,426

April 20, 2023

MEMORANDUM TO: Board of Transportation
FROM: Transportation Planning Division
SUBJECT: Submission of the Craven County Comprehensive Transportation Plan for Mutual Adoption by the Board of Transportation

The Transportation Planning Division has worked cooperatively with the Craven County on their Comprehensive Transportation Plan (CTP). The plan was adopted by Craven County on October 3, 2022, the New Bern Area MPO on January 26, 2023, the Town of Dover on November 1, 2022, the Town of Vanceboro on November 7, 2022, the Town of Cove City on December 6, 2022, and the City of Havelock on January 23, 2023. It was also endorsed by the Down East RPO on January 31, 2023.

The plan is based on an analysis of existing and projected travel and land use, public involvement and field investigations of recommended improvements. It is located on the web at:

https://connect.ncdot.gov/projects/planning/Pages/CTP-Details.aspx?study_id=Craven%20County

The Transportation Planning Division recommends the mutual adoption of the Craven County Comprehensive Transportation Plan.

Sincerely,



Jamal Alavi, P.E.
Director, Transportation Planning Division

Attachment

May 4, 2023

ITEM V

There will be no Item V for the March 4, 2023 Board of Transportation Meeting.

Action – Consideration of the Division of Mitigation Services (DMS) Biennial Budget

Chairman Fox announced that the Board Members received this last month and that they have had the opportunity to review. A motion was made by Board Member Clarke and a second by Board Member Cody to approve the Division of Mitigation Services (DMS) Biennial Budget. Chairman Fox conducted a roll call vote of participating members, and the budget was approved unanimously by members of the Board.

Chairman Fox stated the motion passed.

Committee Reports

Road, Bridge, and Ferry Committee

The committee approved an honorary designation, two bridge namings and an interchange naming:

- Jefferson B Strickland Highway – NC 24 from Underwood Road to Dixie Road in Sampson County – Division 3
- Reverend Thomas L Walker Bridge – Bridge on NC 97 over railroad tracks in Rocky Mount in Division 4 – The applicant requests that this consideration for bridge naming be expedited due to honoree's health condition. Committee approved expediting the designation and resolution was presented earlier.
- Master Trooper Brent Montgomery Bridge – Bridge on SR-1319 (Satterwhite Point Road) over I-85 in Vance County – Division 5
- Edward L. (Ned) Curran Interchange – I-485 / Weddington Road Interchange in Mecklenburg County – Division 10

Committee was informed of Legislative honorary designations and namings that are in the current budget proposal. Staff, per delegated authority, that will make a technical correction in terminus of overlapping namings from 1995 and 2000 on US 421.

E-mail will be sent to update on upcoming events

Finance Committee

1. Financial Update – Stephanie King
 - Revenues are within 6% of the forecast for the year.
 - HF & HTF revenues are in line with forecast with a variance of 3.1% and 8.3%, respectively.
 - Cash as a percentage of commitments in March 2023 is 28%; compared to 30% in March 2022.

- FHWA Federal Aid variance of -\$195.4m is mostly due to receiving GARVEE debt service reimbursement (\$129.3M) in February but forecasted for March.
- FYTD expenditures are 8.9% less than forecast but 21.1% higher as compared to SFY 22.
- Fitch rating agency review affirmed NC's GARVEE Program as A+ with a stable outlook.
- FY22 Performance Audit is complete; released on 4/27/2023.

2. Draft FY24 & FY25 Spend Plan – Michelle Ellis

- The Draft FY 24-25 Spend Plan is based on the FY23 base budget, deducting any non-recurring items. Once the biennial budget is passed, Spend Plan Amendment 1 will be formulated.
- NCDOT is seeking legislative action to issue Build NC in 2024.
- The Consensus Revenue forecast will be taking place in May for any needed adjustments prior to budget passage. Indications are that there will not be vast changes from February's analysis.
- NCDOT is seeking to spend \$7,539 million in total expenditures for SFY 2024 and \$7,918 million in total expenditures for SFY 2025.
- The Spend Plan was voted on by the Committee for consideration and approved to move forward at the June Board Meeting.

3. Revenue Update – Michelle Ellis

- NCDOT has achieved 4,648m in revenue YTD, 1.4% or \$64 million above forecast.
- HF - total FYTD State revenue is \$2,138m; this represents 46% of total NCDOT revenue and is currently 0.53% below forecast.
- HTF – total FYTD State revenue is \$1,361m, this represents 29% of total NCDOT revenue and is currently 0.6% above forecast.

4. Disaster Funding – Emily McGraw

- FHWA provides reimbursement for damages to Federal Aid routes (US, NC, and Interstate routes).
- FHWA funds are potentially available when an event causes at least \$700,000 (Federal share) in eligible damages.
- FEMA gives potential reimbursement for damages to non-Federal Aid State maintained routes.

FEMA recommendation requires the state of NC to exceed the \$18.5M Preliminary Damage Assessment threshold.

Division of Motor Vehicles (DMV) Committee

Previous Meeting (April 5th) minutes approved. Motion by Chuck McGrady, Second by Melvin

Mitchell.

Topic:

NCDMV Recruitment & Staffing Updates presented by Amanda Olive

- Staffing and Vacancies across NCDMV & NCDOT
 - Vacancy rate by County
- Staffing and Turnover
- Retirements
 - Retirement potential over the next five years
- HQ Bonus'
- NCDMV MVP Program

Adjourn Motion by Chuck McGrady. Second by Valerie Jordan.

No actions taken.

EDIR Committee

Mr. Durwood Stephenson, Director of the I-42/US 70 Corridor Commission, provided an update on the Corridor.

Highlights included:

Background

- Corridor Commission began 12 – 15 years ago with intention of improving US 70 to better facilitate movement of traffic and improve economic opportunities in Eastern NC
- Goal of improving to Interstate standards with the first major project being the Goldsboro Bypass
- ASHTO assigned I-42 as route designation

Project Status

- Goldsboro Bypass - completed
- Clayton Bypass - completed
- Havelock Bypass – completed
- Wilson's Mills – under construction

Upcoming projects

- Kinston Bypass
- Princeton Bypass
- I-42 over I-95 in Johnston County

- Map displaying all project segments along with ROW & CON phases presented

Challenges

- Cost escalations & funding concerns

Mr. Tim Anderson, Division Engineer for Div 13, provided an update on Project Ranger. Highlights included:

Background

Pratt and Whitney designs, manufactures, and services airplane engines. The Asheville plant is located in a 1 million square foot facility in Biltmore Park West and will create 800 new direct jobs. The first Phase is 95% complete with the 1st product expected to be produced this month.

Economic & Regional Impacts

- Job creation – both direct & indirect
 - 150+ already hired at Asheville location
- Avg wage of \$68k annually
- \$650M investment in real and business personal property
- Pratt and Whitney is actively conducting job outreach in the area
- Community College is offering technical courses related to Machining and a Certified Production Technician program
- On-site 20k square foot A-B Tech training center dedicated to manufacturing technology
- Numerous partnerships related to economic development incentives, training, land grants, infrastructure improvements, etc.

Site Constraints

- Bordered by I-26, French Broad River, Historic Biltmore Estate, and the Blue Ridge Parkway

Initial Access

- Biltmore Farms constructed bridge across French Broad and access road to site
 - Began in Feb 2021 and added to State System during the March Board meeting
- NCDOT committed to constructing an interchange for East / West connection from I-26 to NC 191 and access to site
 - Multiple I-26 access challenges such as environmental commitments, mountainous terrain, bat moratorium, and material cost escalation
 - Continue efforts to seek Economic Development funding options as well as researching value engineering options to defray cost and keep project on schedule
 - Initial construction budget of \$30M

- Discussed the current status of the project with successful delivery anticipated by the Fall of 2025

Advanced Technology Committee

Call to Order at 3:07 PM, (Board of Transportation Chairman Fox) Clarke, Cody, McGrady, Molamphy, and Phillips in attendance. All present members attended in-person. Absent Members: (Committee Members) Zimmer (Chair), Wells (Vice Chair), Lathrop, and Moran.

March 1, 2023, meeting minutes were approved as distributed with a motion by Committee Member Cody, seconded by Committee Member Clarke.

Executive Director J.J. Eden introduced the topic of *Our Roadmap to the Connected Vehicle World*.

Chris Garlick, Director of Innovation and Strategy, NC Turnpike Authority, shared a presentation titled: *Our Roadmap to the Connected Vehicle World*.

The meeting concluded with a brief open discussion of the presentation by all attending Committee Members.

The meeting was adjourned at 3:55pm a motion by Committee Member Clarke, seconded by Committee Member McGrady.

Workforce Committee

Chairman Grady Hunt called the May 3, 2023, Workforce Development Committee meeting to order, conducted a roll call of members present, and declared a quorum was present. Chair Hunt read the non - conflict/ethics statement and asked if there were any known conflicts of interest. The March 1, 2023, minutes were unanimously approved by the Workforce Development Committee.

Secretary Ebony Pittman presented the HBCU Outreach update.

- HBCU Outreach Strategic Priorities: Expand diversity in the transportation industry through employment and contracting; Value and promote a culture of diversity and inclusion at NCDOT; Establish strategic alliances and advocacy efforts; Strengthen the sustainability of NC's HBCUs/MSIs; Connect HBCUs and minorities with emerging trends in transportation. We are making this happen through our HR unit, our partnership with historically black colleges, and minority serving institutions.
- Strategic Plan and Core Programs: HBCU/MSI Fellowship Program, HBCU/MSI Internship Program, SummerSTEM Program, HBCU/MSI Scholarship Program, HBCU/MSI Research Consortium, National Summer Transportation Institute, and HBCU Alumni Employee Resource Group.
- Internship Program: program is an ideal way for undergraduate students to gain direct work experience with NCDOT and interns are assigned to different areas in transportation. Since 2016, 162 interns have participated in the program with 8 interns moving into the fellowship programs, including 5 interns gaining permanent employment with NCDOT.

- Fellowship Program: program offers individuals a two-year fellowship experience tailored to their interests and goals. Since 2018, 27 fellows have participated with 4 gaining permanent employment with NCDOT.
- Scholarship Program: students who attend can apply for a \$1,500 scholarship that provides financial assistance each year. Since 2018, more than 250 students have applied for the program and 88 awards have been given. \$24,000 was awarded to 16 students for the 2022-23 academic school year through this program.

Another program we offer is the National Summer Transportation Institute which is one of the Federal Highway Administration's key educational initiatives. The institute is a Summer STEM Program: aimed at introducing middle and high school students particularly minority, female, and disadvantaged youth to transportation careers. This program is administered by accredited colleges, community colleges and universities, accredited MSIs across the nation. We are creating a diverse workforce pipeline starting at elementary to post college.

Tunya Smith presented the OJT/EEO Update.

- The NCDOT On-the-Job Training Program: assists minorities, women, veterans, and others historically underrepresented in highway construction job opportunities. The program's goal is to train and prepare program participants to meet a certain skill level in the highway construction sector and this allows us to build a well-diversified pool of skilled workers. The OJT program is involved with community partners and stakeholders to establish a pool of skilled workers.
- Highway Construction Trade Academies: sponsored statewide and hosted by community-based organizations. The academies complement and assist the workforce pipeline for the mandatory On-the-Job Training Program. For 2 years, the academies have been held in several locations statewide, including NCWorks Career Center Elizabeth City and numerous NCDOT maintenance yards across the state. OJT plans to offer at least 1 academy in all 14 highway divisions.
- Pop-up Academies: accelerated boot camp version, which serves as a refresher course of the two-week model of the OJT/Supportive Services Highway Construction Trade Academies. 101 participants trained for entry-level positions with prime contractors and NCDOT's Division of Highways in 2022. The goal is to have at least 1 Pop-Up in all 14 highway divisions. To date, 22 people have completed the program and 2 hired by DOH maintenance yards.

OJT hosts hiring events and career fairs which include middle and high school students to get our young people interested early in transportation careers.

The OCR program is also engaged in the effort to attract more Native Americans to all of our programs by working closely with the 8 NC tribes and the NC Commission of Indian Affairs.

- OJT 2022-23 major accomplishments include: 309 prime contractor employees enrolled into the program; new formula and methodology that included division-let contracts; 34 contractors participating in the OJT compliance program; 78 new enrollments; and 23 graduates to journeyman status.
- The Equal Employment Opportunity (EEO) Unit: investigates complaints of unlawful discrimination, harassment, and retaliation; issues determinations at the conclusion of EEO informal inquiries; and submits agency position statements to the appropriate federal or state agency.
- EEO Recent Accomplishments: Submitted EEO State Plan to OSHR; EEO and ServiceNow Development are underway; Hired EEO investigator; Backlog of EEO

cases has been cleared up.

- Workforce Best Practices: Quarterly reports to NCDOT business units; EEO on-site evaluations; Disciplinary actions annual report; DEI focus at NCDOT; Training EEO and Diversity Fundamentals required for each new supervisor; Fundamentals of Management is required annually; Review and approval of 3,075 hiring packages during 2022.

Other Business/Closing Comments

Chairman Fox shared with the Board and attending staff that Jamie Keith, Policy & Operations Manager, is leaving state government. He thanked her for all her hard work during her 4 years with the Governance office and expressed that she would be missed greatly. He encouraged everyone to wish her well when they saw her.

Next Meeting

The next Board meeting will be held June 5-6, 2023, in Charlotte. The Board will be touring Division 10 during this travel trip. The July Board meeting is a one-day virtual meeting. The Chairman announced that the Board won't be back together in Raleigh until the August Board meeting.

Adjournment

Chairman Fox asked if there were any additional items for discussion. He stated hearing none he would accept a motion to adjourn the meeting. A motion was made by Board Member Perkins and seconded by Board Member Clarke. Chairman Fox stated the motion passed unanimously.

Chairman Fox adjourned the meeting.

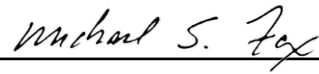

Chairman Fox

North Carolina Board of Transportation

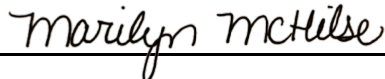
Attest: 

Secretary to the Board of Transportation

Dated this day June 6, 2023

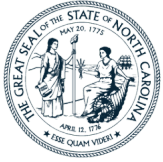

NORTH CAROLINA
Department of Transportation

Financial and Spend Plan Update As of March 2023

Stephanie King, Chief Financial Officer





Finance Committee Meeting

May 2023

Connecting people, products and places safely and efficiently with customer focus, accountability and environmental sensitivity to enhance the economy and vitality of North Carolina

Executive Summary

The Fast Five

 <p>Revenues</p>	<ul style="list-style-type: none"> • Revenues are within -5.8% of the forecast for the year. • HF and HTF revenues are largely in line with forecast with a variance of 3.1% and 8.3%, respectively. • Cash as a percentage of commitments in March 2023 is 28%; compared to 30% in March 2022. • FHWA Federal Aid variance of -\$195.4 is mostly due to receiving GARVEE debt service reimbursement (\$129.3M) in February but forecasted for March.
 <p>Expenditures</p>	<ul style="list-style-type: none"> • FYTD expenditures are 8.9% less than forecast but 21.1% higher as compared to SFY 22. • Largest variances are in Construction (\$238.0M) & Maintenance (\$193.5M) due to material and labor issues. • Mobility & Modernization, Undeclared disaster and Bridge Program show the largest variance in Maintenance.
 <p>FY24-25 Spend Plan</p>	<ul style="list-style-type: none"> • The Draft FY 24-25 Spend Plan is based on the FY23 base budget, deducting any non-recurring items. Once the biennial budget is passed, Spend Plan Amendment 1 will be formulated. • Seeking legislative action in order to issue Build NC in 2024. • Consensus revenue forecast will be taking place in May for any needed adjustments prior to budget passage. Indications are that there will not be vast changes from February's analysis.
 <p>Benchmarking Financial Health</p>	<ul style="list-style-type: none"> • Agency has worked with Ernst & Young to better benchmark parameters for financial and operational health. • Extends actions beyond cash as the primary indicator to include days of cash on hand and percentage of cash over commitments. • Actions will include recommendations to advance work efforts and quickly address necessary warning signs.
 <p>General Updates</p>	<ul style="list-style-type: none"> • Fitch rating agency review affirmed NC's GARVEE Program as A+ with a stable outlook. • FY22 Performance Audit is complete; released on 4/27/2023. • Quarterly Revenue Updates will be presented to the BOT Finance Committee to include leading indicators. Economist and others will be working to refine the information in the months ahead. • Efforts continue with SAS, Ernst & Young, OSBM, and DOT on the long-term forecasting tool. Hybrid approach was used in the March update.

Revenues

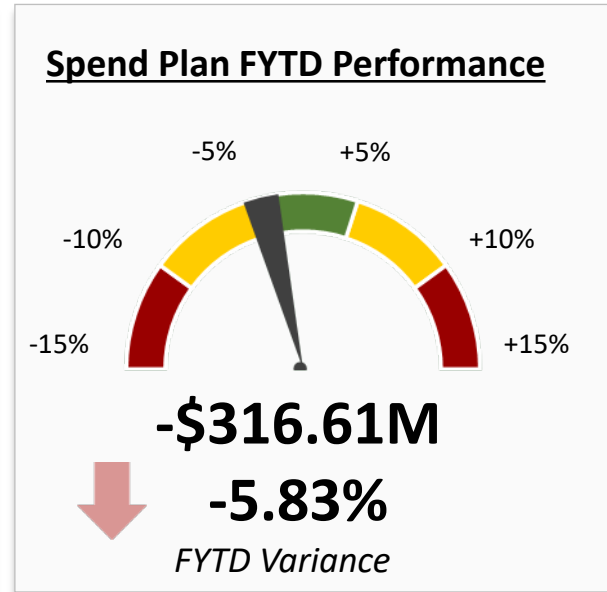
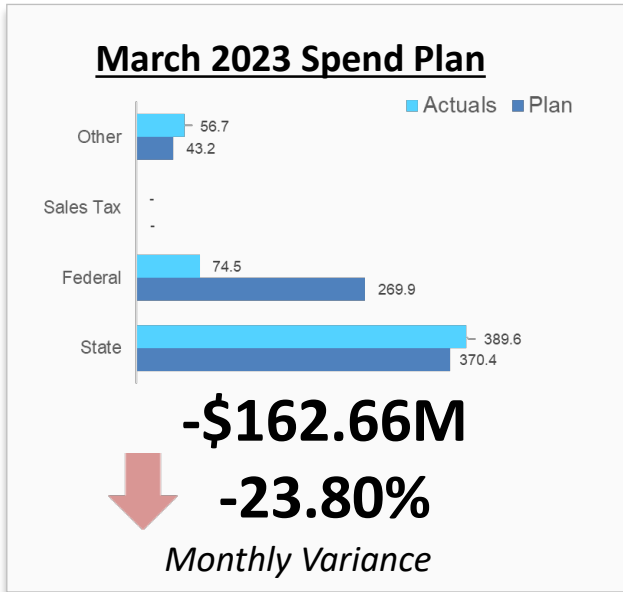

- ### Revenue Commentary
- Motor Fuel Taxes, Highway Use, DMV Fees, and Sales taxes are closely in alignment with the spend plan forecast.
 - FYTD revenues have a negative variance of 5.8% primarily due to Federal Revenues.
 - FHWA Federal Aid variance of -\$195.4 is largely due to receiving GARVEE debt service reimbursement of \$129.3M in February when forecasted for March, creating a variance due to timing.
 - In addition, DOT is making efforts to increase FHWA billings over the next 3-4 months by about \$5 million weekly.

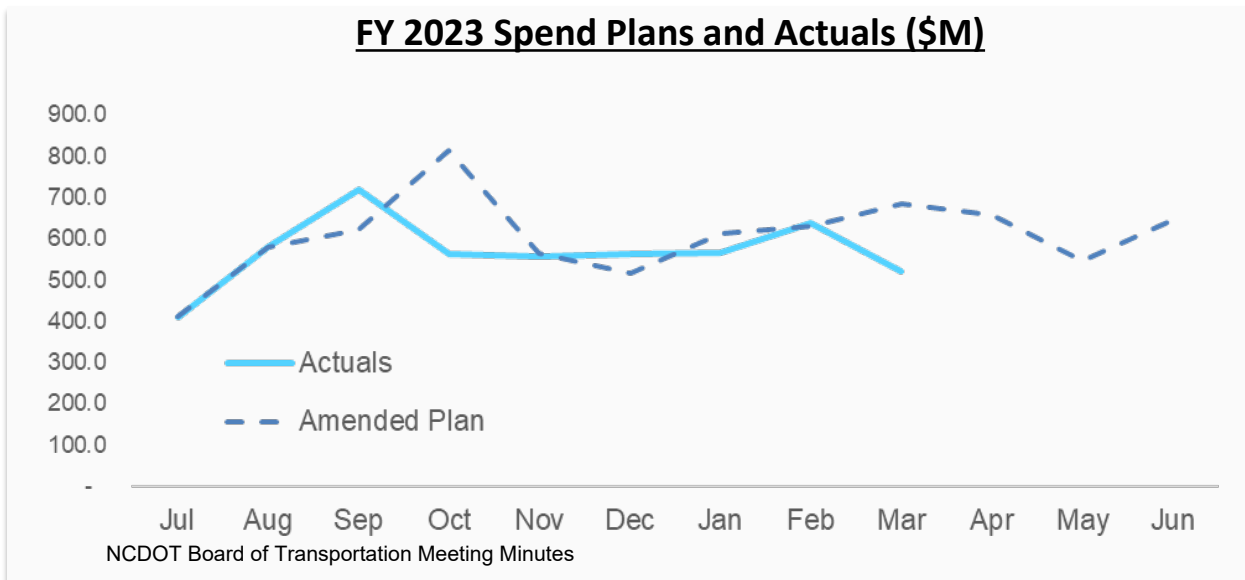

Expenses

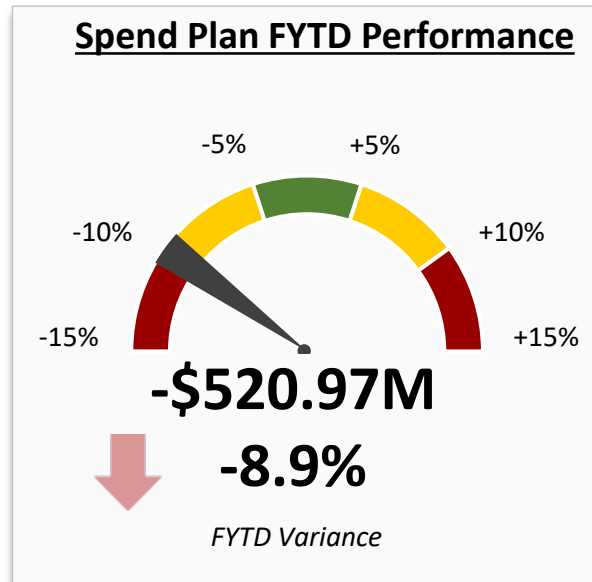
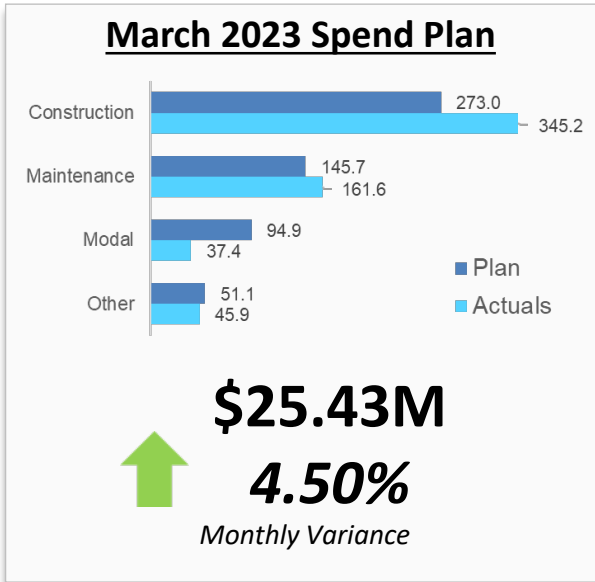

Expense Commentary

- Overall negative FYTD variance to spend plan is -8.9% or \$-521.0M; attributable to Construction and Maintenance.
- Positive monthly variance to spend plan is 4.5%; Expenditures are in line with forecast due to construction picking up.
- FYTD overall Construction and Maintenance expenditures continue to fall behind forecast due to labor and material shortages.
- Overall expenditures are up YOY, increasing by 21.1%

May 4, 2023



Financial Highlights

Cash

Cash Balance
\$2,399M

Highway Trust Fund: **\$1,441m**
 Other*: **\$19m**
 Trust Fund: **\$939m**

FY23 FCST Avg. Monthly Expenditures
\$591M

Days Cash On Hand
123.4

Last Month: 123.1

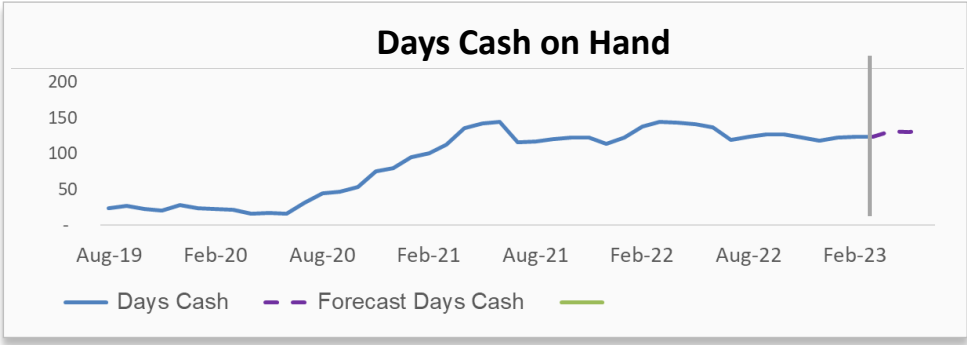

Commitments

Open Commitments
\$8,681M

Last Month: \$8,454M

Category	Percentage
Construction	74%
Maintenance	17%
Other	6%
Modal	3%

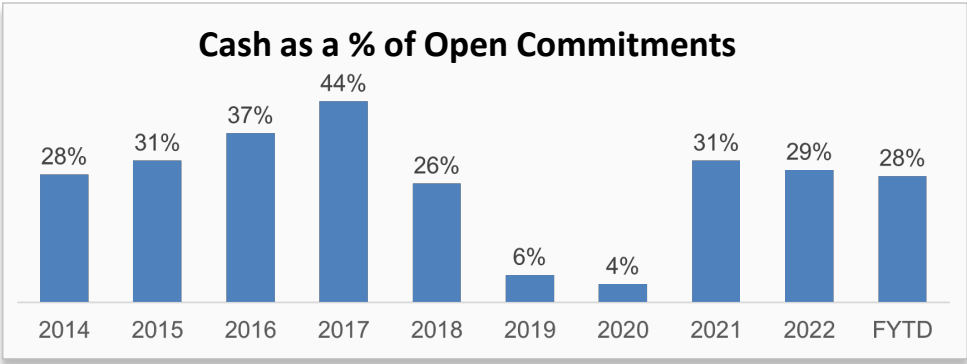

Project Activity

New Active Projects
 March

75 Projects
\$300.1M
 (Bid Amounts)

Month	# of Projects	Bid (\$m)
June	48	150
July	81	350
August	50	750
September	28	150
October	39	550
November	17	150
December	16	50
January	29	250
February	20	350
March	75	300.1

Accepted Projects
 March

43 Projects
\$105.1M
 (Estimate to Date)

Month	# of Projects	Estimate (\$m)
June	52	450
July	28	100
August	30	150
September	41	500
October	58	150
November	24	100
December	42	150
January	31	100
February	46	200
March	43	105.1

Description	Actuals		Variance - Fiscal Year to Date			Track Against Full Year Spend Plan	
	Actuals As of 03/31	Fiscal YTD Spend Plan	\$ Variance, FYTD	% Variance, FYTD	Full Year Spend Plan	% of SFY 2023 Spend Plan	
Total Revenues & Other Receipts	5,118.40	5,435.00	(316.61)	-6%	7,284.63	70%	
State revenues	3,392.14	3,368.39	23.75	1%	4,580.60	74%	
Federal aid	1,110.31	1,237.65	(127.33)	-10%	1,587.97	70%	
Federal aid - USDOT Discretionary Grants	16.35	22.14	(5.79)	-26%	23.98	68%	
Turnpike Federal Aid	23.68	(0.03)	23.71	-88743%	(0.03)	-88643%	
Sales Tax	106.16	96.55	9.61	10%	193.10	55%	
Other	130.97	350.46	(219.49)	-63%	444.27	29%	
Garvee	117.16	121.24	(4.08)	-3%	150.06	78%	
BuildNC	221.63	238.60	(16.97)	-7%	304.68	73%	
Total Construction	2,791.85	3,029.84	(237.99)	-8%	4,179.94	67%	
Garvee Expenditures	165.95	395.23	(229.28)	-58%	554.29	30%	
Garvee Debt Service	154.33	154.34	(0.01)	0%	154.34	100%	
Division of Mitigation Services (Formerly EEP)	0.05	16.53	(16.47)	-100%	23.13	0%	
BUILDNC Expenditures	484.88	428.24	56.64	13%	581.69	83%	
BUILDNC Debt Service	26.81	26.81	-	0%	121.44	22%	
STIP Construction - SAS	1,136.71	861.34	275.38	32%	1,201.88	95%	
NC Mobility Fund	0.00	(0.00)	0.00	-1935%	(0.00)	-1835%	
STIP Preconstruction & Holdouts	563.52	957.11	(393.59)	-41%	1,286.82	44%	
TIP - USDOT Discretionary Grants	181.22	164.78	16.44	10%	220.03	82%	
Turnpike Authority	46.25	1.88	44.38	2366%	2.25	2060%	
Internal Orders	11.14	0.15	10.99	7452%	3.15	354%	
Congestion Mitigation & Air Quality (CMAQ)	20.97	23.44	(2.46)	-11%	30.94	68%	
Total Maintenance	1,660.76	1,854.35	(193.59)	-10%	2,499.28	66%	
Other Construction - Secondary Roads	10.91	11.13	(0.23)	-2%	20.43	53%	
Other Construction - Spot Safety Improvements	11.06	11.30	(0.24)	-2%	13.53	82%	
Other Construction - Contingency	10.65	8.84	1.82	21%	10.02	106%	
Other Construction - Mobility/Modernization	334.02	425.03	(91.01)	-21%	447.19	75%	
General Maintenance Reserve	386.10	408.28	(22.18)	-5%	595.25	65%	
Contract Resurfacing	414.16	397.32	16.84	4%	604.04	69%	
Roadside Environmental	94.94	77.72	17.21	22%	112.34	85%	
Pavement Preservation	73.90	68.19	5.71	8%	107.01	69%	
Bridge Program	204.27	245.20	(40.93)	-17%	330.49	62%	
Bridge Preservation	66.16	68.23	(2.08)	-3%	98.37	67%	
Emergency GMR	41.81	86.57	(44.77)	-52%	93.73	45%	
Disaster Funding - FEMA	12.79	46.53	(33.74)	-73%	66.90	19%	
Total Other Modes	378.12	435.98	(57.87)	-13%	531.96	71%	
Administration	230.53	265.02	(34.49)	-13%	378.45	61%	
Transfers to Other State Agencies	49.80	50.55	(0.75)	-1%	67.39	74%	
Transfers to General Fund/NCTA - GAP Funds	36.75	36.75	-	0%	49.00	75%	
State aid to municipalities	154.85	154.88	(0.03)	0%	154.88	100%	
Debt Service	-	-	-	na	-	na	
Other Programs	18.97	15.24	3.74	25%	21.23	89%	
Total Other Expenditures	490.90	522.43	(31.53)	-6%	670.95	73%	
Total Expenditures	5,321.63	5,842.60	(520.97)	-9%	7,882.13	68%	

Actual Revenues and Expenditures Compared to Spend Plan

24 Month Cash Forecast – SFY 23 / SFY 24 Spend Plan

Projected Cash Balances and Statutory Thresholds

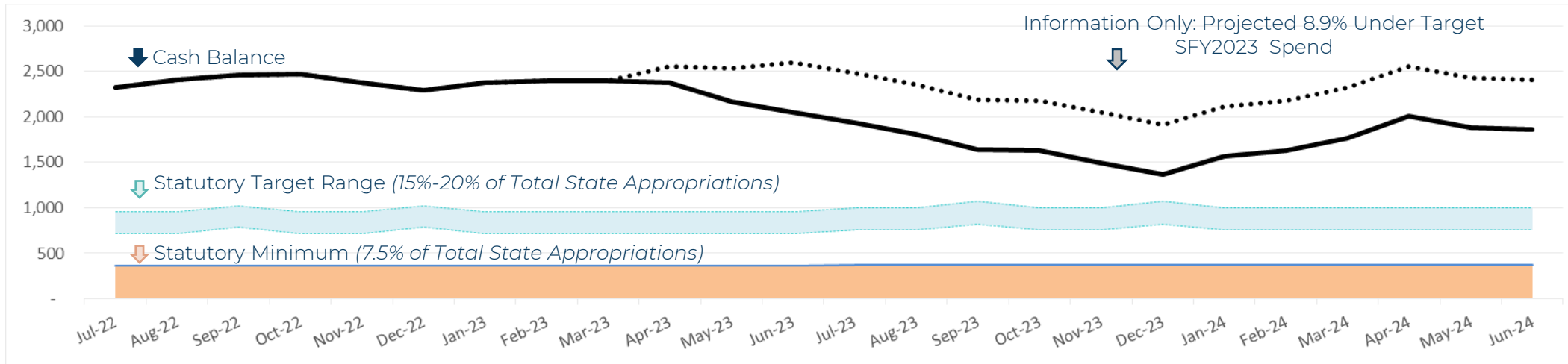

Commentary

- Cash balance as of March 2023 is \$2.399B.
- Balance is above the **Statutory Target Range**, per N.C.G.S. 143C-6-11.
 - Range is between 15% and 20% of the total appropriations for the current fiscal year or \$716 million and \$955 million, respectively.
- The **Statutory Minimum** line has a cash balance requirement of \$358 million.

Notes on Cash Balance

- Reflects 24 mo. Spend Plan approved by BOT on October 5th
- Conventional, D-B, Build NC, USDOT Discretionary Grants & GARVEE - SAS Project Expenditure Model (Using the Hybrid Model)
- Federal Revenue including Obligation Authority
- Placeholder for Spring 2024 Build NC Issuance

Detailed Report

Days Cash on Hand

As of March 2023 month end the Department has ~120 days of cash on hand

Days Cash on Hand (Jun 2019 to Mar 2023)

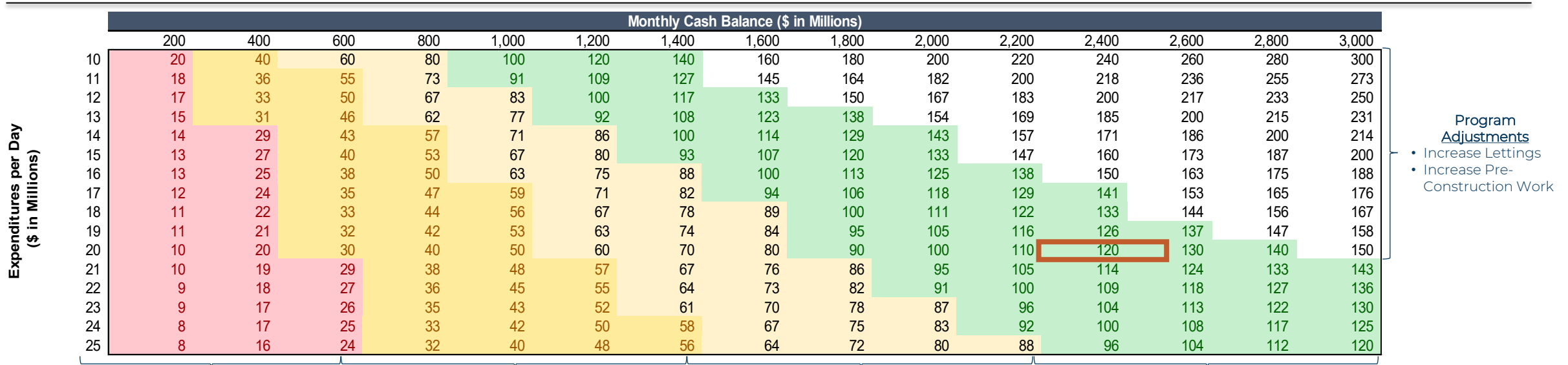

- Program Adjustments**
- Increase Lettings
 - Increase Pre-Construction Work

Program Adjustments¹

- Stop Maintenance Lettings & Activities
- Stop Construction Lettings
- Stop Non-Essential Purchase Order Activity

Additional Key Parties Notified

- All notifications in yellow/ light yellow sections as well as;
- Joint Legislative Transportation Oversight Committee

Program Adjustments¹

- Reduce Administrative Spend
- Reduce Pre-Construction Work
- Delay Maintenance Activities
- No Overtime/No Temporary Staff
- Delay Right of Way Purchases

Additional Key Parties Notified

- All notifications in light yellow section as well as;
- Office of State Budget and Management,
- Department of State Treasurer

Program Adjustments¹

- Reduce Mowing Expenses
- Reduce Overtime Work
- Reduce Travel
- Reduce Equipment Rental

Key Parties Notified

- Secretary
- Chairman of the BOT
- BOT Finance Chairman and Co-Chairman
- Financial Planning Committee.

Program Adjustments¹

- No Program Adjustments Needed

Key

 < 30 Days	 60 – 89 Days	 > 143 Days
 30 – 59 Days	 90 – 143 Days	 Current Days

Monthly Ending Cash as a % of Commitments Table

Cash as a % of open commitments is ~ 28% as of March 2023 month end

Monthly Ending Cash as a % of Commitments (Jun 2019 to Mar 2023)

Commitments (\$ in Millions)	Monthly Cash Balance (\$ in Millions)														
	200	400	600	800	1,000	1,200	1,400	1,600	1,800	2,000	2,200	2,400	2,600	2,800	3,000
6,000	3%	7%	10%	13%	17%	20%	23%	27%	30%	33%	37%	40%	43%	47%	50%
6,200	3%	6%	10%	13%	16%	19%	23%	26%	29%	32%	35%	39%	42%	45%	48%
6,400	3%	6%	9%	13%	16%	19%	22%	25%	28%	31%	34%	38%	41%	44%	47%
6,600	3%	6%	9%	12%	15%	18%	21%	24%	27%	30%	33%	36%	39%	42%	45%
6,800	3%	6%	9%	12%	15%	18%	21%	24%	26%	29%	32%	35%	38%	41%	44%
7,000	3%	6%	9%	11%	14%	17%	20%	23%	26%	29%	31%	34%	37%	40%	43%
7,200	3%	6%	8%	11%	14%	17%	19%	22%	25%	28%	31%	33%	36%	39%	42%
7,400	3%	5%	8%	11%	14%	16%	19%	22%	24%	27%	30%	32%	35%	38%	41%
7,600	3%	5%	8%	11%	13%	16%	18%	21%	24%	26%	29%	32%	34%	37%	39%
7,800	3%	5%	8%	10%	13%	15%	18%	21%	23%	26%	28%	31%	33%	36%	38%
8,000	3%	5%	8%	10%	13%	15%	18%	20%	23%	25%	28%	30%	33%	35%	38%
8,200	2%	5%	7%	10%	12%	15%	17%	20%	22%	24%	27%	29%	32%	34%	37%
8,400	2%	5%	7%	10%	12%	14%	17%	19%	21%	24%	26%	29%	31%	33%	36%
8,600	2%	5%	7%	9%	12%	14%	16%	19%	21%	23%	26%	28%	30%	33%	35%
8,800	2%	5%	7%	9%	11%	14%	16%	18%	20%	23%	25%	27%	30%	32%	34%
9,000	2%	4%	7%	9%	11%	13%	16%	18%	20%	22%	24%	27%	29%	31%	33%

- Program Adjustments**
- Increase Lettings
 - Increase Pre-Construction Work

Program Adjustments¹

- Stop Maintenance Activities
- Stop Construction Lettings
- Stop Non-Essential Purchase Order Activity
- Reduction in Workforce

Additional Key Parties Notified

- All notifications in yellow/ light yellow sections as well as;
- Joint Legislative Transportation Oversight Committee

Program Adjustments¹

- Reduce Administrative Spend
- Reduce Pre-Construction Work
- Delay Maintenance Contracts
- No Overtime/No Temporary Staff
- Delay Right of Way Purchases

Additional Key Parties Notified

- All notifications in light yellow section as well as;
- Office of State Budget and Management,
- Department of State Treasurer

Program Adjustments¹

- Reduce Mowing Expenses
- Reduce Travel
- Reduce Overtime Work
- Reduce Equipment Rental

Key Parties Notified

- Secretary
- Chairman of the BOT
- BOT Finance Chairman and Co-Chairman
- Financial Planning Committee.

Program Adjustments¹

- No Program Adjustments Needed

Key

 <10% OC	 18% – 25% OC	 > 33% OC
 10% – 17% OC	 26% – 33% OC	 Current %

Days Cash & Ending Cash as a % of Commitments Over Time



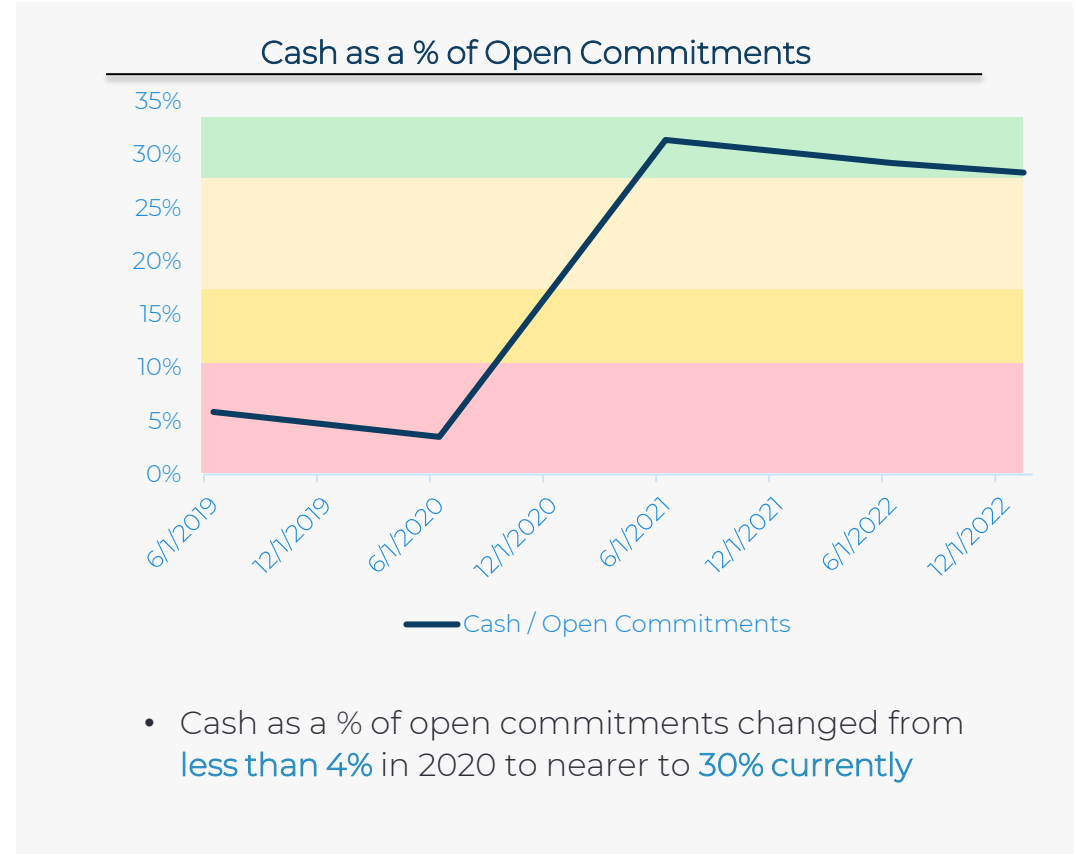
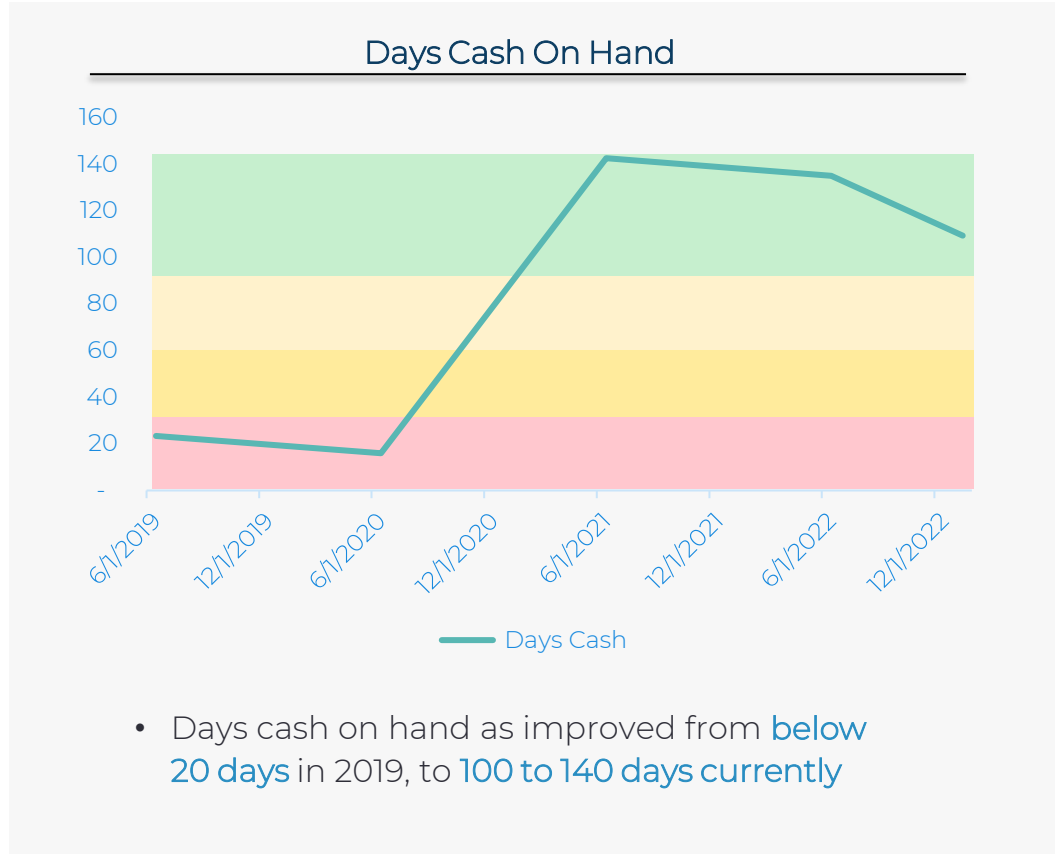



Both metrics of Days Cash on Hand and Cash as a % of Open Commitments have drastically improved from 2020 to current



The monitoring and considerations taken at each escalation stage are designed to allow NCDOT to deliver on its strategic initiatives

Cash Monitoring and Management

Notifications and potential agency action will occur if one or more metrics is no longer green

	Actuals, March 31	Max Values in Next Lower Tier	Minimum Values
Days Cash on Hand	123 	89 	29 
Cash as a % of O/C	28% 	25% 	9% 

Range of Metric Dictates Actions

A proportional approach is taken depending on what range the key metrics of cash on hand and as a % of open commitments fall into

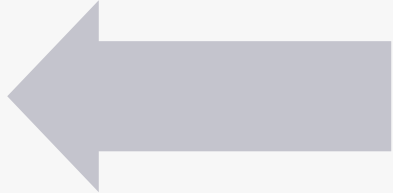
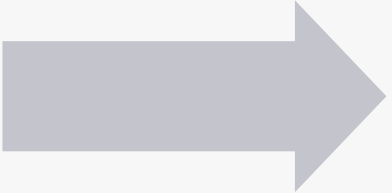
	Light Yellow 18%-25% Commitments / 60-89 Days	Yellow 10%-17% Open Commitments / 30-59 Days Cash	Red <10% Open Commitments / < 30 Days Cash
Notification	<p><u>The CEO will notify the following:</u></p> <ul style="list-style-type: none"> • Secretary • Chairman of the BOT • BOT Finance Chairman and Co-Chairman • Financial Planning Committee. 	<p><u>All notifications in light yellow as well as:</u></p> <ul style="list-style-type: none"> • Office of State Budget and Management • Department of State Treasurer 	<p><u>All notifications in yellow/ light yellow as well as:</u></p> <ul style="list-style-type: none"> • Joint Legislative Transportation Oversight Committee
Consideration		<ul style="list-style-type: none"> • Both metrics in same range? • Expectation to improve/worsen over next 3 to 12 months? • Entering peak construction season? • Any large one-off transactions which will then return to normal? • Are federal reimbursements coming in as expected? 	
Actions	<ul style="list-style-type: none"> • Reduce travel to only essential functions • Establish a percentage spend reduction for all areas • Implement a hiring freeze • Reduce non-essential Purchase Order activities (e.g. mowing) • Begin reviewing plans for all ROW purchases and pending PE contracts 	<p><u>All actions in light yellow as well as:</u></p> <ul style="list-style-type: none"> • Reduce pre-construction activities (such as ROW purchases) • Delay maintenance activities 	<p><u>All notifications in yellow/ light yellow as well as:</u></p> <ul style="list-style-type: none"> • Halt all maintenance and construction lettings and other maintenance activities • Review all program cost for additional cuts (DMV, IMD areas, etc.)

Transportation Revenue Sources SFY 2023 - \$7.29 Billion

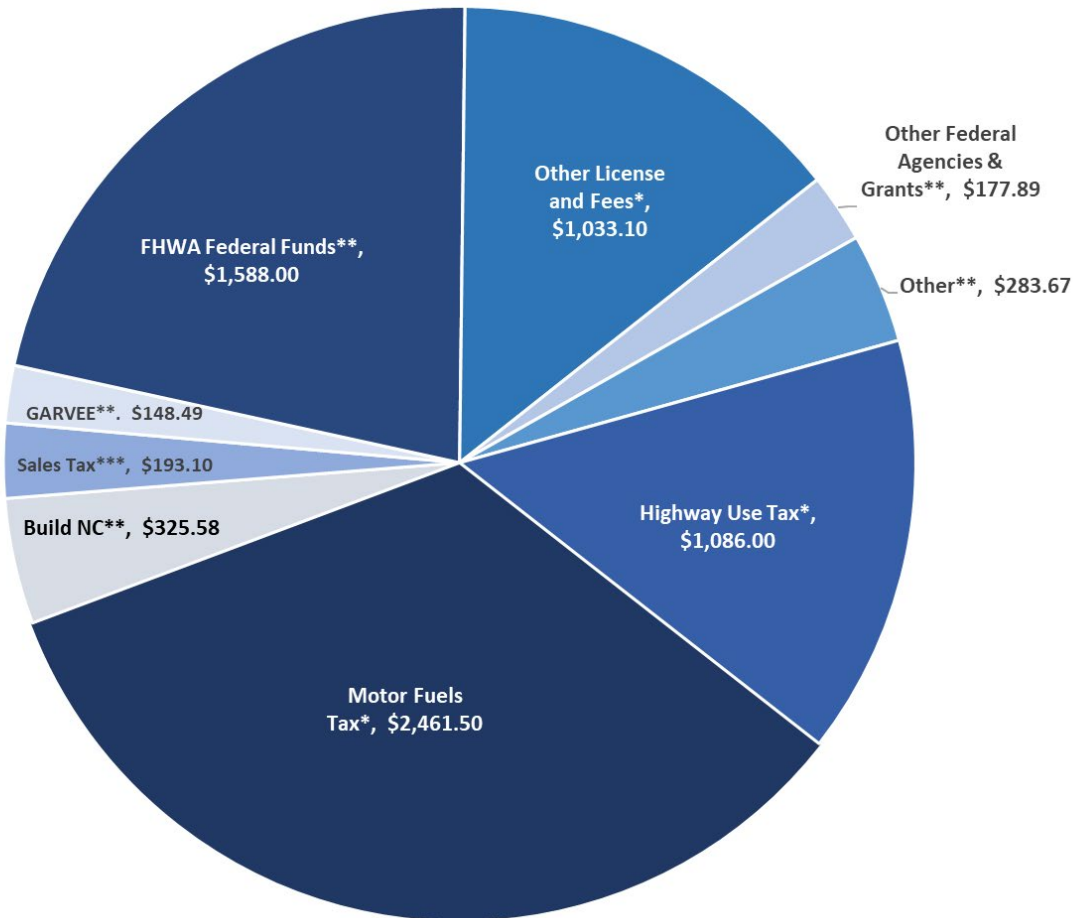

Transportation Uses 2022-23 Appropriations - \$6.4 Billion (Excludes Receipt Supported Funding of \$0.2B)

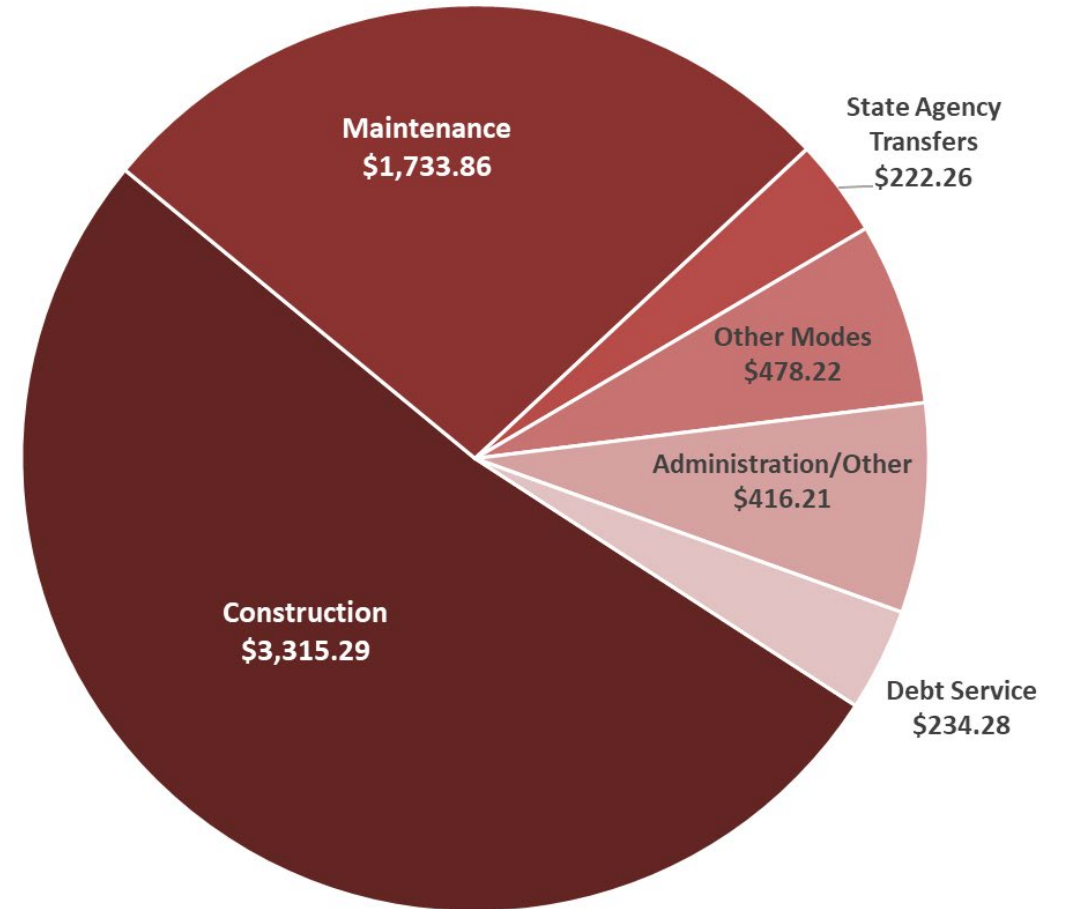

* State Revenue
 ** Federal, Bond, Grant and Other Revenue from August Monthly Update (SP Amend 2)
 *** Sales Tax from SL 2022-74 (SP Amend 1)

YOY Financial Analysis for March

Highway Fund

Cash balance decreased by \$54.8M or 3.7%

- \$1,495.5M in Mar22 to \$1,440.7M in Mar23
- Cash decrease can be attributable to overall expenditures increasing and overall working capital decreasing.

Revenues decreased by \$18.7M or 7.5%

- \$247.5M in Mar22 to \$228.9M in Mar23
- \$7.4M decrease in MFT revenues
- \$14.2M decrease in license & fee revenues
- \$0.3M increase in HUT revenues

Expenses (current accounts) increased by \$14.0M or 75.1%

**YTD Revenues increased by \$139.9M
YTD Expenses (current) increased by \$61.4M**

Highway Trust Fund

Cash balance decreased by \$43.0M or 4.4%

- \$982.2M in Mar22 to \$939.2M in Mar23
- Cash decrease can be attributable to overall expenditures increasing.

Revenues increased by \$8.6M or 5.7%

- \$152.1M in Mar22 to \$160.7M in Mar23
- \$9.2M increase in MFT revenues
- \$1.7M decrease in HUT revenues
- \$0.7M decrease in fee revenues

Expenses (current accounts) increased by \$0.3M or 2.0%

**YTD Revenues increased by \$162.8M
YTD Expenses (current) increased by \$5.6M**

Financial Update - SFYTD 2023 as compared SFYTD 2022 (\$ in millions)

	Month over Month		Year to Date	
	March 2023	March 2022	YTD 2023	YTD 2022
<u>HF, TF, and Ferry Capital</u>				
Collections	\$521M	\$555M	\$5,118M	\$4,996M
Expenditures	\$590M	\$418M	\$5,322M	\$4,395M
Net Change	-\$69M	\$137M	-\$203M	\$601M
Cash Balances:			March 2023	March 2022
Highway Fund *			\$1,441M	\$1,495M
Highway Trust Fund			\$939M	\$982M
Ferry Capital Fund			\$19M	\$22M
Totals			\$2,399M	\$2,499M

*Excludes bond proceeds held by Trustee

Revenue Summary and Variances – Monthly (\$M)

Variance to Spend Plan - Month of Mar

March Variance: (\$162.7)m, (23.8%) of Spend Plan

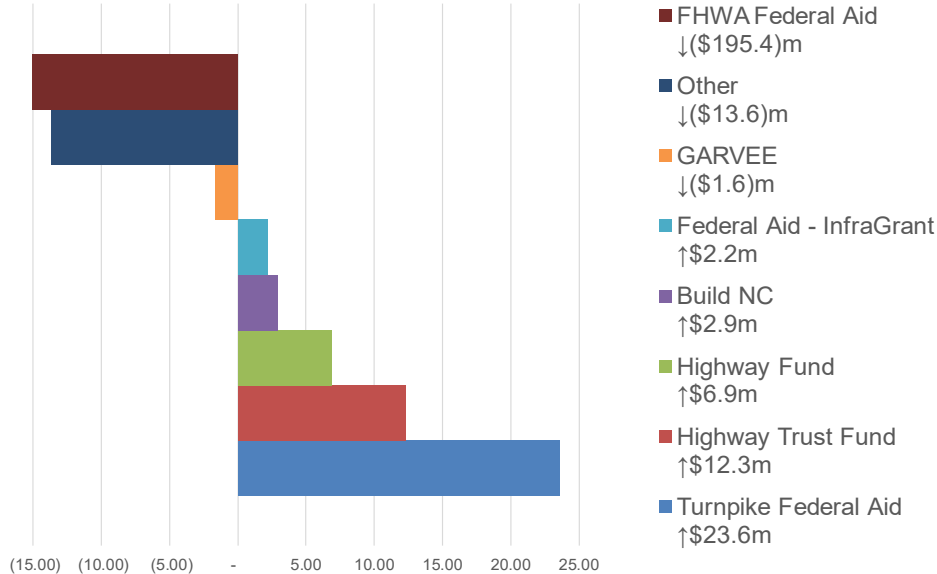

Commentary

- Overall negative monthly variance to spend plan: 23.8% (\$162.7M)
- FHWA Federal Aid variance of -\$195.4 is mostly due to receiving GARVEE debt service reimbursement (\$129.3M) in February but forecasted for March. Also, \$23.6 of FHWA billings were recorded under Turnpike Federal Aid instead of FHWA Federal Aid.
- HF and HTF revenues are largely in line with forecast with a variance of 3.1% and 8.3%, respectively.
- Other revenues had a negative variance of 122% (\$13.6M) primarily due to a transfer made to the Turnpike Authority:

Description	Actuals For Month Ending 03/31	Variance to Spend Plan - Monthly		Variance to Prior Year- Monthly			
		Spend Plan	\$ Variance, Monthly	% Variance, Monthly	Prior Year	\$ Variance, Monthly	% Variance, Monthly
Highway Fund	228.86	221.96	6.90	3%	247.47	(18.61)	-8%
Highway Trust Fund	160.73	148.41	12.32	8%	152.12	8.61	6%
FHWA Federal Aid	74.53	269.88	(195.35)	-72%	110.71	(36.19)	-33%
Federal Aid - InfraGrant	2.87	0.66	2.20	332%	1.27	1.59	125%
Turnpike Federal Aid	23.57	-	23.57	na	0.01	23.56	na
Sales Tax	-	-	-	na	-	-	na
Other	(2.48)	11.16	(13.64)	-122%	9.25	(11.73)	-127%
GARVEE	10.69	12.31	(1.62)	-13%	24.69	(14.00)	-57%
Build NC	22.04	19.09	2.95	15%	9.85	12.19	124%
Total Revenues	520.81	683.47	-162.66	-24%	555.38	-34.57	-6.2%

Revenue Summary and Variances – Fiscal Year to Date (\$M)

Variance to Spend Plan - Fiscal Year to Date

Total Variance (\$316.6)m, (5.8%) of Forecast to Date

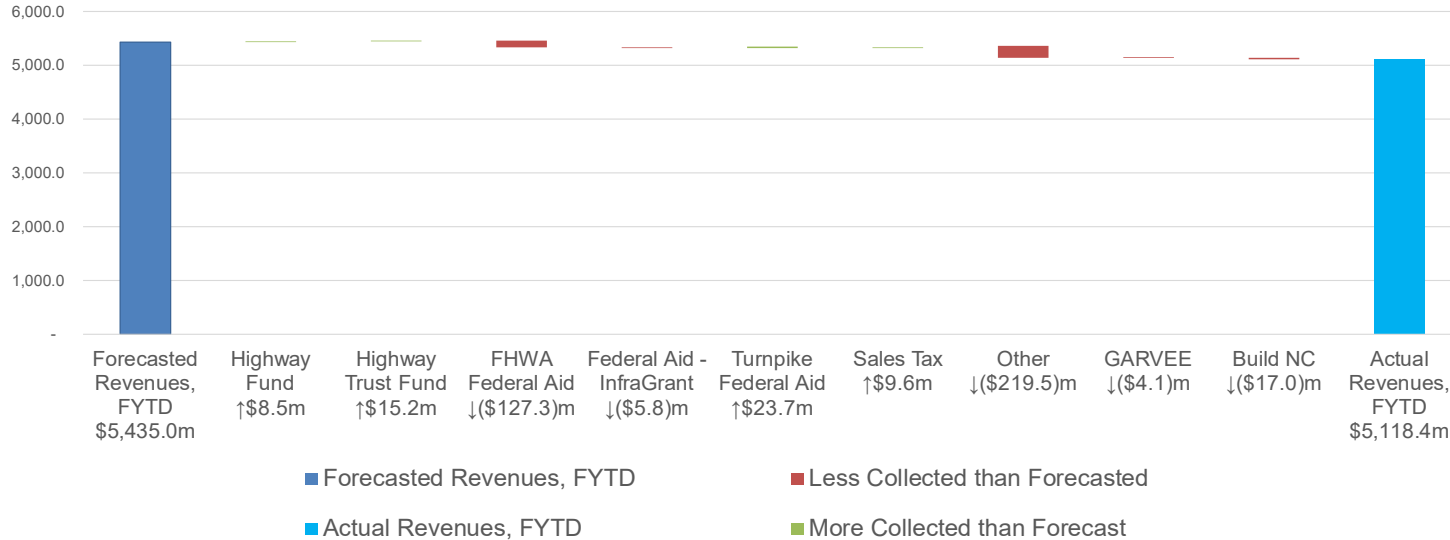

Commentary

- Overall negative FYTD variance to spend plan is -5.8% or \$-316.6M.
- HF and HTF revenues are on point with forecast; 0.4% and 1.1%, respectively.
- YOY growth in HF (1.7%) & HTF (13.6%) revenues.
- Negative FYTD variance is due to Other Revenue – the Economic Development transfer from the Department of Commerce (DOC) and FHWA Federal Aid.

Description	Actuals		Variance - Fiscal Year to Date		Track Against Full Year Spend Plan		Variance to Prior Year- FYTD		
	Actuals As of 03/31	Fiscal YTD Spend Plan	\$ Variance, FYTD	% Variance, FYTD	Full Year Spend Plan (Amendment 2)	% of SFY 2023 Spend Plan	Prior Year	\$ Variance, FYTD	% Variance
Highway Fund *	2,031.50	2,022.98	8.52	0%	2,749.45	74%	1,996.98	34.52	2%
Highway Trust Fund	1,360.63	1,345.41	15.22	1%	1,831.16	74%	1,197.82	162.81	14%
FHWA Federal Aid	1,110.31	1,237.65	(127.33)	-10%	1,587.97	70%	902.36	207.95	23%
Federal Aid - InfraGrant	16.35	22.14	(5.79)	-26%	23.98	68%	13.96	2.38	17%
Turnpike Federal Aid	23.68	(0.03)	23.71	-88743%	(0.03)	-88643%	0.32	23.36	7366%
Sales Tax	106.16	96.55	9.61	10%	193.10	55%	-	106.16	na
Other	130.97	350.46	(219.49)	-63%	444.27	29%	431.46	(300.49)	-70%
GARVEE	117.16	121.24	(4.08)	-3%	150.06	78%	248.18	(131.02)	-53%
Build NC	221.63	238.60	(16.97)	-7%	304.68	73%	204.54	17.09	8%
Total Revenues	5,118.40	5,435.00	-316.61	-5.8%	7,284.63	70%	4,995.62	122.77	2.5%

NCDOT Board of Transportation Meeting Minutes
 * Sales Tax is not included; Note Sales Tax is broken out below.

Highway Fund & Trust Fund Details March 2023(\$M)

FYTD YoY Variance

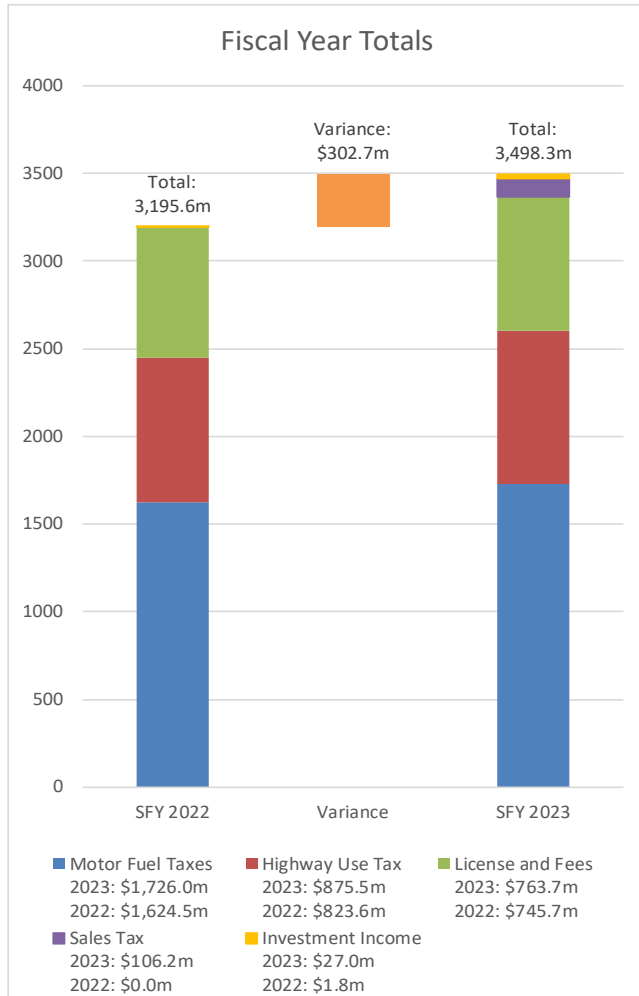

Monthly YoY Variance

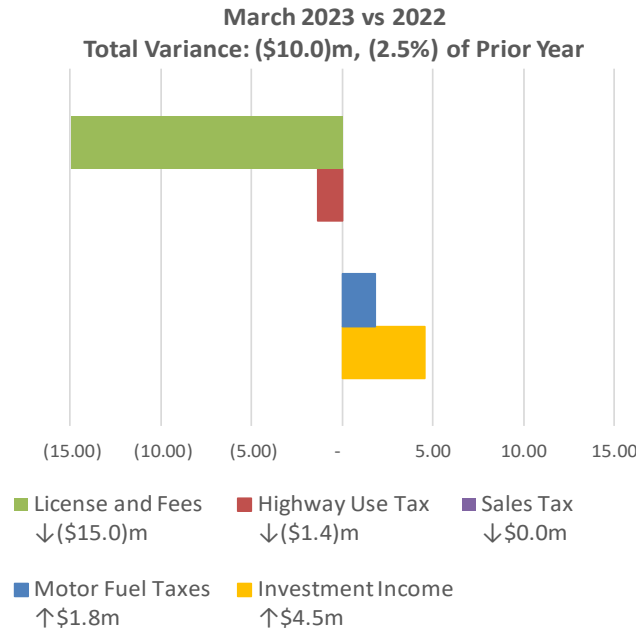

Commentary

- FYTD Highway Fund and Trust Fund revenues have grown by 9.5% on a combined basis as compared to Mar 22.
- March YTD Motor Fuel Tax, Highway Use Tax, and License & Fees are up YOY; 6.3%, 6.3%, and 2.4%, respectively.
- Investment income increased exponentially YOY due to rising interest rates.
- There was no Sales Tax revenue in March.

Revenue	Comparison to Prior Year - Month of March		Comparison to Prior Year - Fiscal Year to Date			
	March 2023	March 2022	Current FYTD Actual Revenue (Jul '22 - Mar '23)	Previous FYTD Actual Revenue (Jul '21 - Mar '22)	FYTD YoY \$ Δ	FYTD YoY % Δ
	Motor Fuel Taxes	177.8	176.0	1,726.0	1,624.5	101.5
Highway Use Tax	106.6	107.9	875.5	823.6	51.9	6.3%
License and Fees	100.4	115.4	763.7	745.7	18.0	2.4%
Investment Income	4.8	0.3	27.0	1.8	25.2	1417%
Sales Tax	-	-	106.2	-	106.2	na
Total Revenue	\$389.6	\$399.6	\$3,498.3	\$3,195.6	\$302.7	9.5%

Overall Expenditure Variances – Monthly (\$M)

Variance to Spend Plan - Month of Mar

Mar Variance: \$25.4m, 4.5% of Spend Plan

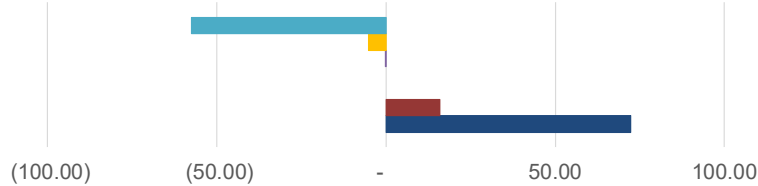

- Other Modes ↓(\$57.5)m
- Municipal Aid ↓\$0.0m
- Construction ↑\$72.2m
- Transfers to Other Agencies ↓(\$5.1)m
- NCTA GAP funds /Emergency Reserve ↓\$0.0m
- Maintenance (including FEMA) ↑\$15.9m
- Administrative /Other Programs ↓(\$0.1)m

Monthly Expenditure Makeup*

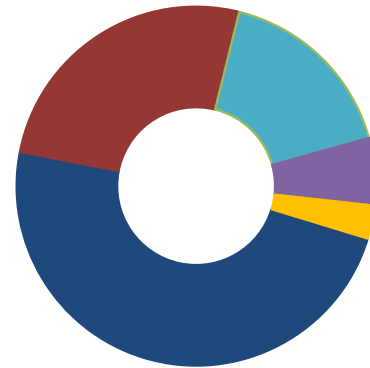

- Construction, 48%
- Maintenance (including FEMA), 26%
- Other Modes, 17%
- Administration/Other Programs, 6%
- NCTA GAP funds / Emergency Reserve, 0%
- Municipal Aid, 0%
- Transfers to Other Agencies, 3%

Commentary

- Overall positive monthly variance to spend plan in March of 4.5% largely due to Construction.
- Construction has a positive variance of 26.4% or \$72.2M.
- Maintenance has a positive variance of 10.9% or \$15.9M due to Mobility Modernization and Contract Resurfacing.
- Modal has a negative variance of 60.6% or \$57.5M due to Railroad.

Description	Actuals		Variance - Monthly			Variance to Prior Year- Monthly		
	Actuals For Month Ending 03/31	Spend Plan	\$ Variance, Monthly	% Variance, Monthly	Prior Year	\$ Variance, Monthly	% Variance, Monthly	
Construction	345.21	273.00	72.21	26%	207.68	137.53	66%	
Maintenance (including FEMA)	161.55	145.68	15.87	11%	128.49	33.06	26%	
Other Modes	37.41	94.87	(57.46)	-61%	46.47	(9.06)	-19%	
Administration/Other Programs	34.20	34.28	(0.08)	0%	23.73	10.47	44%	
NCTA GAP funds / Emergency Reserve	-	-	-	na	-	-	na	
Municipal Aid	-	-	-	na	-	-	na	
Transfers to Other Agencies	11.74	16.85	(5.11)	-30%	11.70	0.04	0%	
Total Expenditures	590.11	564.68	25.43	5%	418.07	172.04	41%	

Overall Expenditure Summary and Variances – Fiscal YTD (\$M)

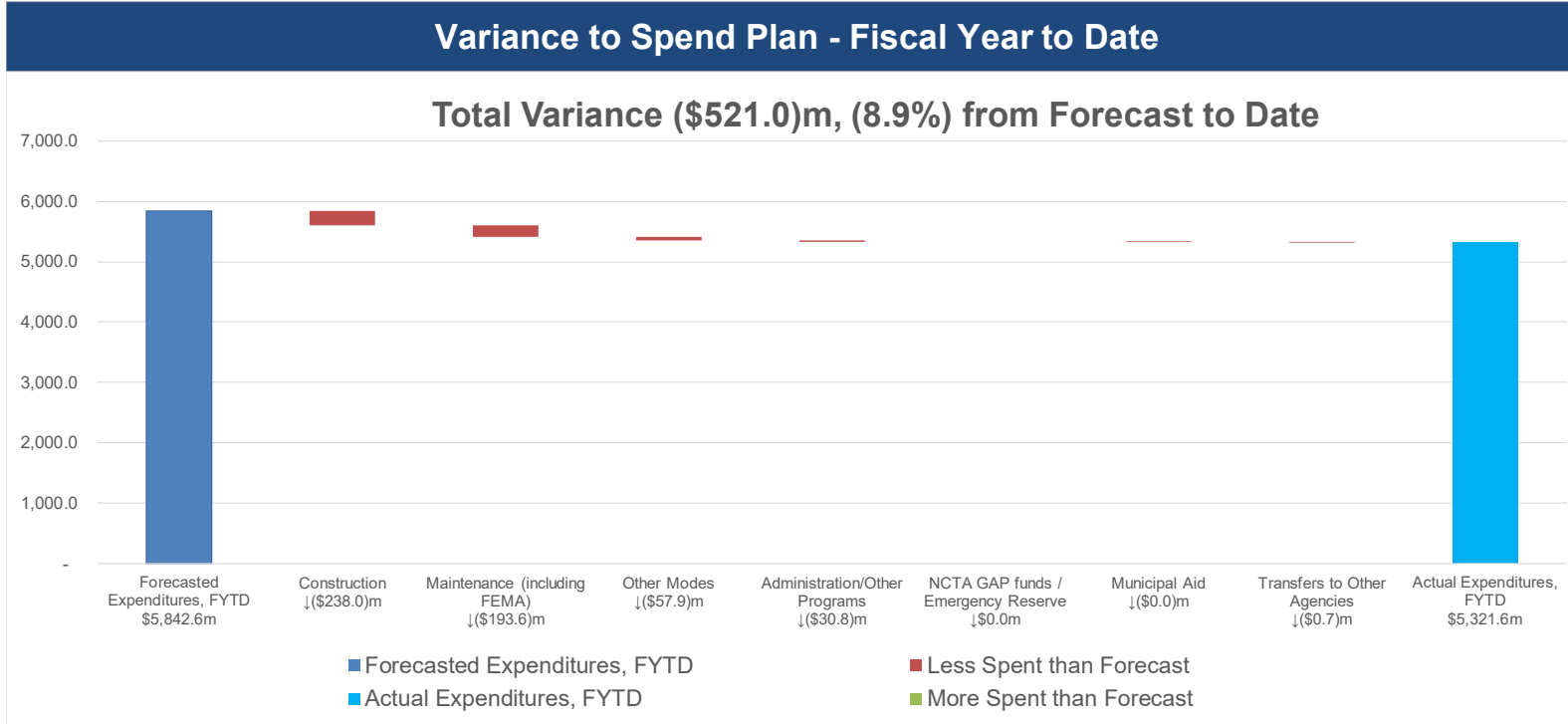

Commentary

- Overall expenditures are up YOY, increasing by 21.1% from \$4,395.1M FYTD March 2022 to \$5,321.6M FYTD March 2023, although labor and material shortages are continuing to lead to expenditures falling behind forecast.
- The FYTD variance to spend has dropped from October to March. October having a -15% FYTD variance and March having a -8.9% FYTD variance.

Description	Actuals		Variance - Fiscal Year to Date		Track Against Full Year Spend Plan		Variance to Prior Year- FYTD		
	Actuals As of 03/31	Fiscal YTD Spend Plan	\$ Variance, FYTD	% Variance, FYTD	Full Year Spend Plan (Amendment 2)	% of SFY 2023 Spend Plan	Prior Year	\$ Variance, FYTD	% Variance
Construction	2,791.85	3,029.84	(237.99)	-8%	4,179.94	67%	2,370.87	420.98	18%
Maintenance (including FEMA)	1,660.76	1,854.35	(193.59)	-10%	2,499.28	66%	1,181.68	479.08	41%
Other Modes	378.12	435.98	(57.87)	-13%	531.96	71%	312.49	65.63	21%
Administration/Other Programs	249.50	280.26	(30.76)	-11%	399.68	62%	221.80	27.71	12%
NCTA GAP funds / Emergency Reserve	36.75	36.75	-	0%	49.00	75%	97.75	(61.00)	-62%
Municipal Aid	154.85	154.88	(0.03)	0%	154.88	100%	159.21	(4.36)	-3%
Transfers to Other Agencies	49.80	50.55	(0.75)	-1%	67.39	74%	51.27	(1.46)	-3%
Total Expenditures	5,321.63	5,842.60	-520.97	-9%	7,882.13	68%	4,395.06	926.57	21%

Maintenance Expenditure Variances – Monthly (\$M)

Variance to Spend Plan - Month of Mar

Mar Variance: \$15.9m, 10.9% of Spend Plan

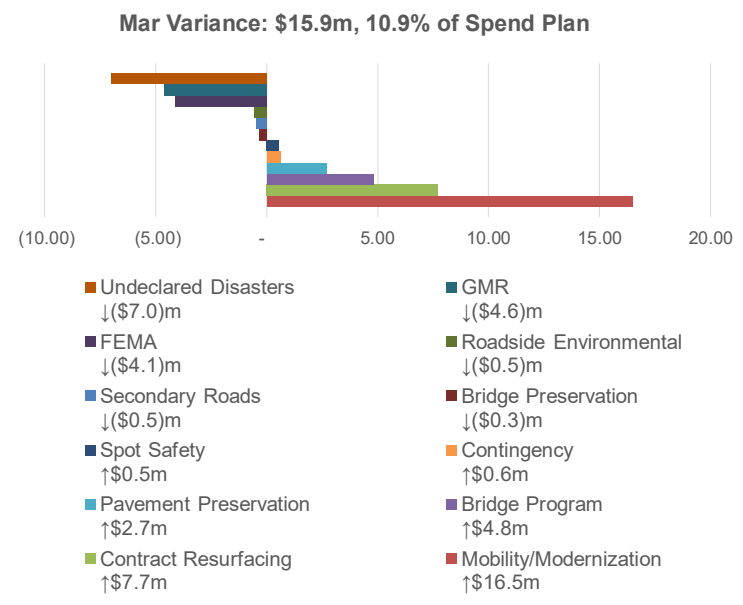

Monthly Expenditure

Maintenance is 25.8% of March Spend Plan

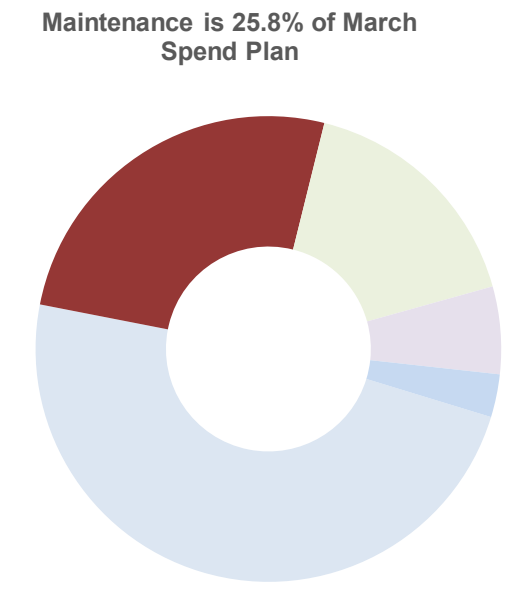

Commentary

- Maintenance expenditures had an overall positive monthly variance to spend plan in March of 10.9%.
- Overall positive variance can be attributable to Mobility Modernization (\$16.5M) and Contract Resurfacing (\$7.7M).
- Undeclared Disaster expenditures had a negative variance of \$7.0M as a result of the mild winter weather.

Description	Actuals		Variance - Monthly		Variance to Prior Year- Monthly			
	Actuals For Month Ending 03/31	Spend Plan	\$ Variance, Monthly	% Variance, Monthly	Prior Year	\$ Variance, Monthly	% Variance, Monthly	
Secondary Roads	1.03	1.51	(0.48)	-32%	0.56	0.46	82%	
Spot Safety Improve.	1.78	1.23	0.55	44%	1.93	(0.15)	-8%	
Contingency	0.80	0.18	0.62	337%	0.22	0.59	270%	
Mobility/Modernization	30.41	13.92	16.49	118%	17.91	12.50	70%	
GMR	53.30	57.89	(4.59)	-8%	44.82	8.48	19%	
Contract Resurfacing	24.88	17.16	7.72	45%	18.64	6.24	33%	
Roadside Environmental	6.71	7.23	(0.52)	-7%	7.06	(0.35)	-5%	
Pavement Preservation	3.73	1.04	2.69	259%	2.99	0.73	24%	
Bridge Program	25.47	20.66	4.80	23%	20.69	4.78	23%	
Bridge Preservation	7.73	8.05	(0.32)	-4%	4.42	3.31	75%	
Undeclared Disasters	3.58	10.55	(6.97)	-66%	6.21	(2.63)	-42%	
FEMA	2.13	6.26	(4.12)	-66%	3.04	(0.90)	-30%	
Total Maintenance	161.55	145.68	15.87	11%	128.49	33.06	26%	

Maintenance Expenditure Summary and Variances – FYTD (\$M)

Variance to Spend Plan - Fiscal Year to Date

Total Variance (\$193.6)m, (10.4%) from Forecast to Date

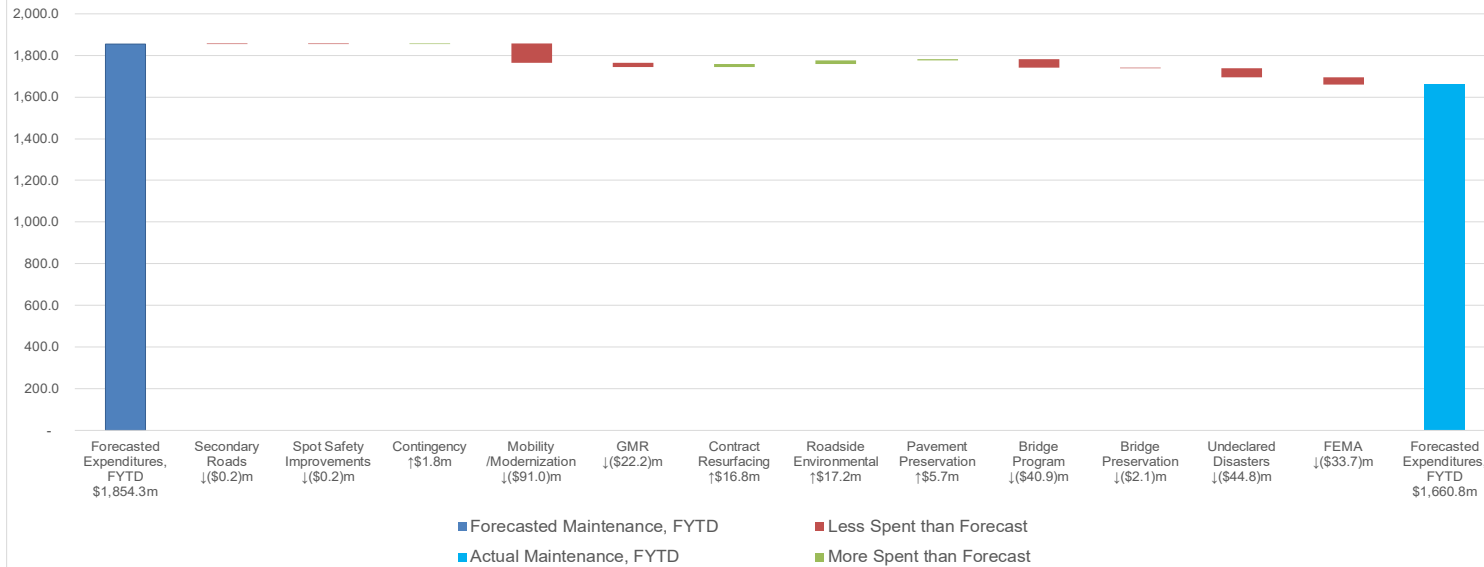

Commentary

- Maintenance expenditures are up significantly YOY, increasing by 40.5% from \$1,181.7M FYTD March 2022 to \$1,660.8M FYTD March 2023.
- Overall FYTD negative variance of 10.4% is due to Mobility Modernization (-\$91.0M), Bridge Program (-\$40.9M), and Undeclared Disasters (-\$44.8M).

Description	Actuals		Variance - Fiscal Year to Date		Track Against Full Year Spend Plan		Variance to Prior Year- FYTD		
	Actuals As of 03/31	Fiscal YTD Spend Plan	\$ Variance, FYTD	% Variance, FYTD	Full Year Spend Plan (Amendment 2)	% of SFY 2023 Spend Plan	Prior Year	\$ Variance, FYTD	% Variance
Secondary Roads	10.91	11.13	(0.23)	-2%	20.43	53%	8.31	2.59	100%
Spot Safety Improve.	11.06	11.30	(0.24)	-2%	13.53	82%	11.62	(0.56)	-5%
Contingency	10.65	8.84	1.82	21%	10.02	106%	7.21	3.45	48%
Mobility/Modernization	334.02	425.03	(91.01)	-21%	447.19	75%	98.99	235.03	237%
GMR	386.10	408.28	(22.18)	-5%	595.25	65%	296.93	89.17	30%
Contract Resurfacing	414.16	397.32	16.84	4%	604.04	69%	339.78	74.38	22%
Roadside Environmental	94.94	77.72	17.21	22%	112.34	85%	75.90	19.04	25%
Pavement Preservation	73.90	68.19	5.71	8%	107.01	69%	51.99	21.91	42%
Bridge Program	204.27	245.20	(40.93)	-17%	330.49	62%	144.28	60.00	42%
Bridge Preservation	66.16	68.23	(2.08)	-3%	98.37	67%	44.61	21.54	48%
Undeclared Disasters	41.81	86.57	(44.77)	-52%	93.73	45%	62.20	(20.39)	-33%
FEMA	12.79	46.53	(33.74)	-73%	66.90	19%	39.87	(27.08)	-68%
Total Maintenance	1,660.76	1,854.35	-193.59	-10%	2,499.28	66%	1,181.68	479.08	41%

Modal Expenditure Variances – Monthly (\$M)

Variance to Spend Plan - Month of Mar

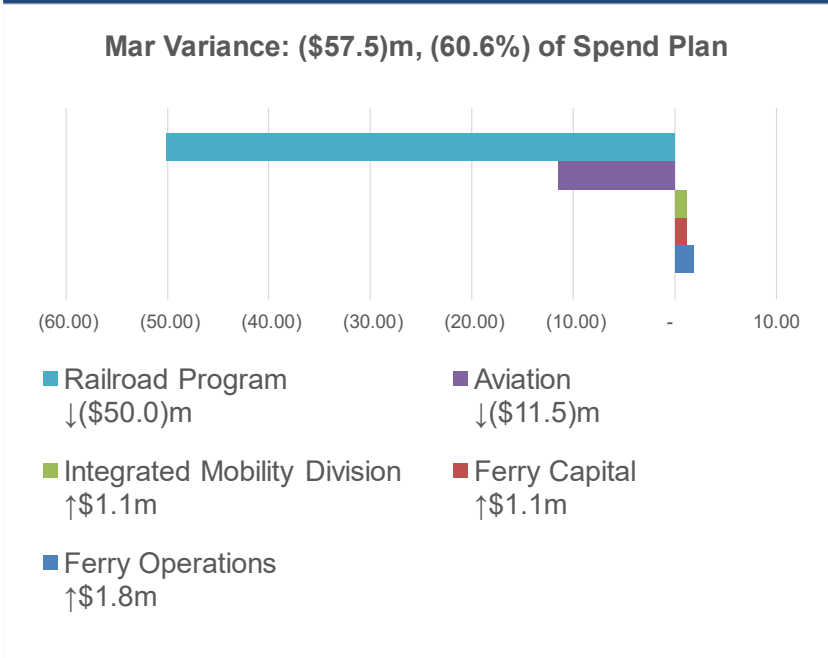

Monthly Expenditure Makeup

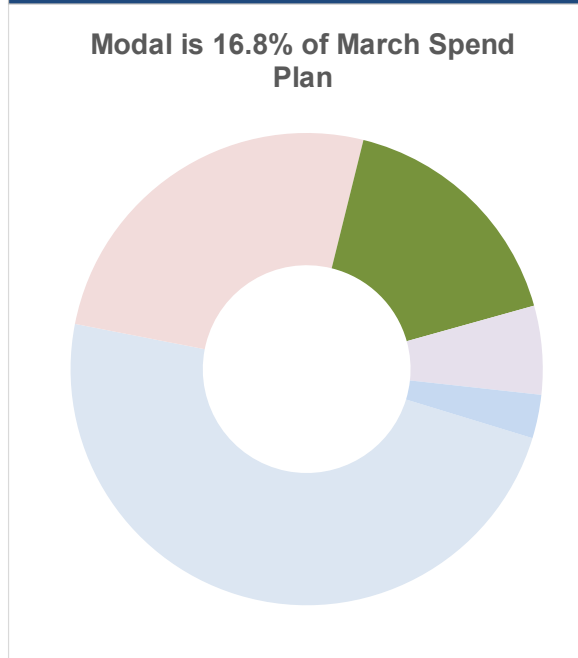

Commentary

- Modal expenditures had an overall negative monthly variance to spend plan in March of 60.6%.
- Overall negative variance can be attributable to Railroad (-\$50.1M) due to the S-line acquisition. Federal funds are still in negotiation.

Description	Actuals		Variance - Monthly			Variance to Prior Year- Monthly		
	Actuals For Month Ending 03/31	Spend Plan	\$ Variance, Monthly	% Variance, Monthly	Prior Year	\$ Variance, Monthly	% Variance, Monthly	
Integrated Mobility Division	7.39	6.28	1.12	18%	7.94	(0.54)	-7%	
Ferry Capital	1.21	0.07	1.14	1705%	na	na	na	
Ferry Operations	6.64	4.86	1.78	37%	5.33	1.31	25%	
Railroad Program	3.50	53.51	(50.01)	-93%	6.15	(2.64)	-43%	
Aviation	18.66	30.15	(11.49)	-38%	27.05	(8.39)	-31%	
Total Modal	37.41	94.87	-57.46	-61%	46.47	-9.06	-19%	

Modal Expenditure Summary and Variances – FYTD (\$M)

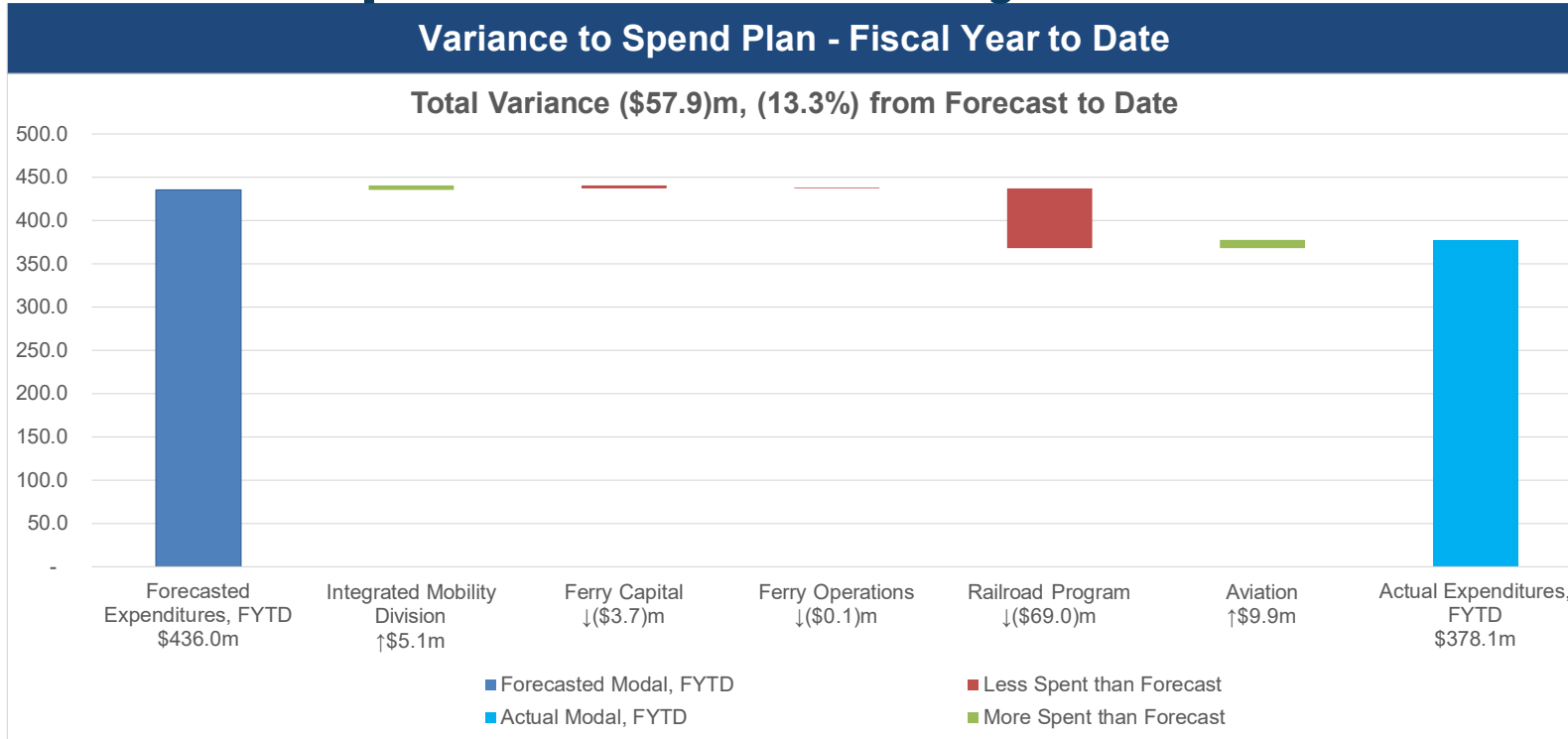

Commentary

- Modal expenditures are up significantly YOY, increasing by 21.0% from \$312.5M FYTD March 2022 to \$378.1M FYTD March 2023.
- IMD has reached 89% of spend for the year.
- Aviation has reached 86% of spend for the year.

Description	Actuals		Variance - Fiscal Year to Date		Track Against Full Year Spend Plan		Variance to Prior Year- FYTD		
	Actuals As of 03/31	Fiscal YTD Spend Plan	\$ Variance, FYTD	% Variance, FYTD	Full Year Spend Plan (Amendment 2)	% of SFY 2023 Spend Plan	Prior Year	\$ Variance, FYTD	% Variance
Integrated Mobility Division	111.23	106.11	5.13	5%	125.00	89%	137.80	(26.56)	100%
Ferry Capital	4.91	8.63	(3.72)	-43%	8.63	57%	-	4.91	na
Ferry Operations	44.61	44.74	(0.13)	0%	58.45	76%	38.64	5.97	15%
Railroad Program	29.66	98.68	(69.02)	-70%	121.59	24%	25.00	4.65	19%
Aviation	187.71	177.83	9.88	6%	218.29	86%	111.05	76.65	69%
Total Modal	378.12	435.98	-57.87	-13%	531.96	71%	312.49	65.63	21%

NCDOT Outstanding Commitments & Closing Cash Balances by State Fiscal Year

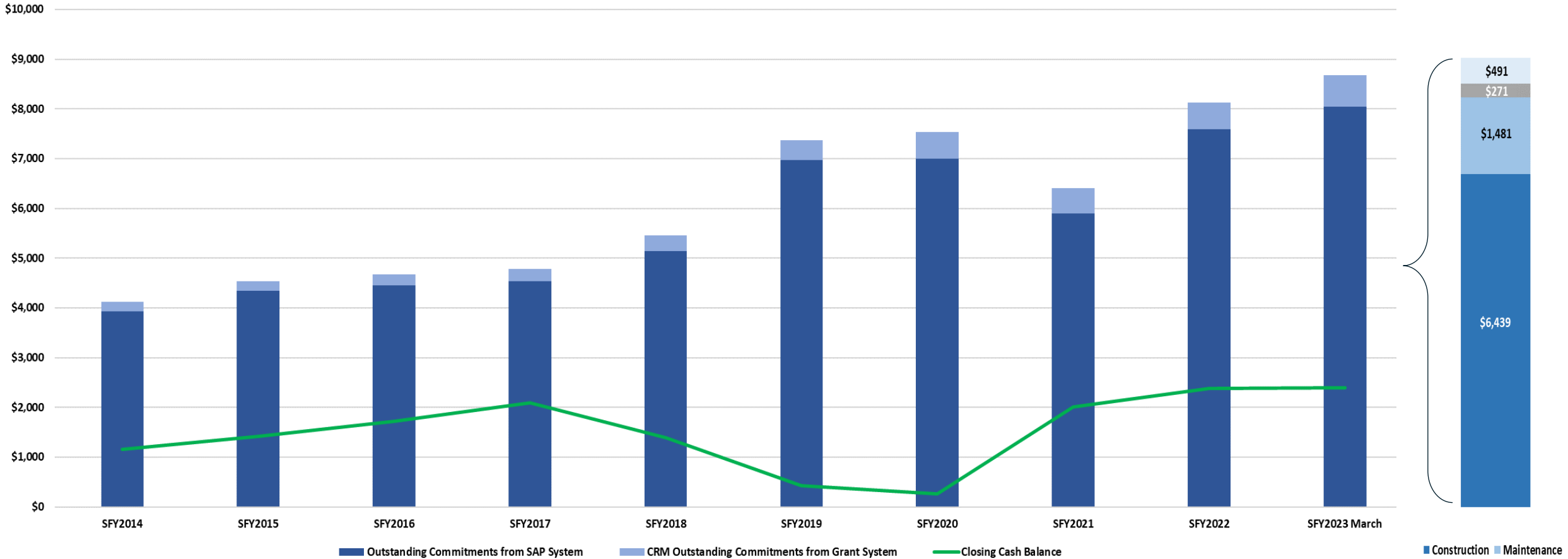

Percentage of Outstanding Commitments by Year

SFY <= 2017	SFY 2018	SFY 2019	SFY 2020	SFY 2021	SFY 2022	SFY 2023
2.94%	2.49%	9.51%	12.19%	5.19%	33.42%	34.26%

NCDOT Outstanding Commitments & Closing Cash Balances by Month

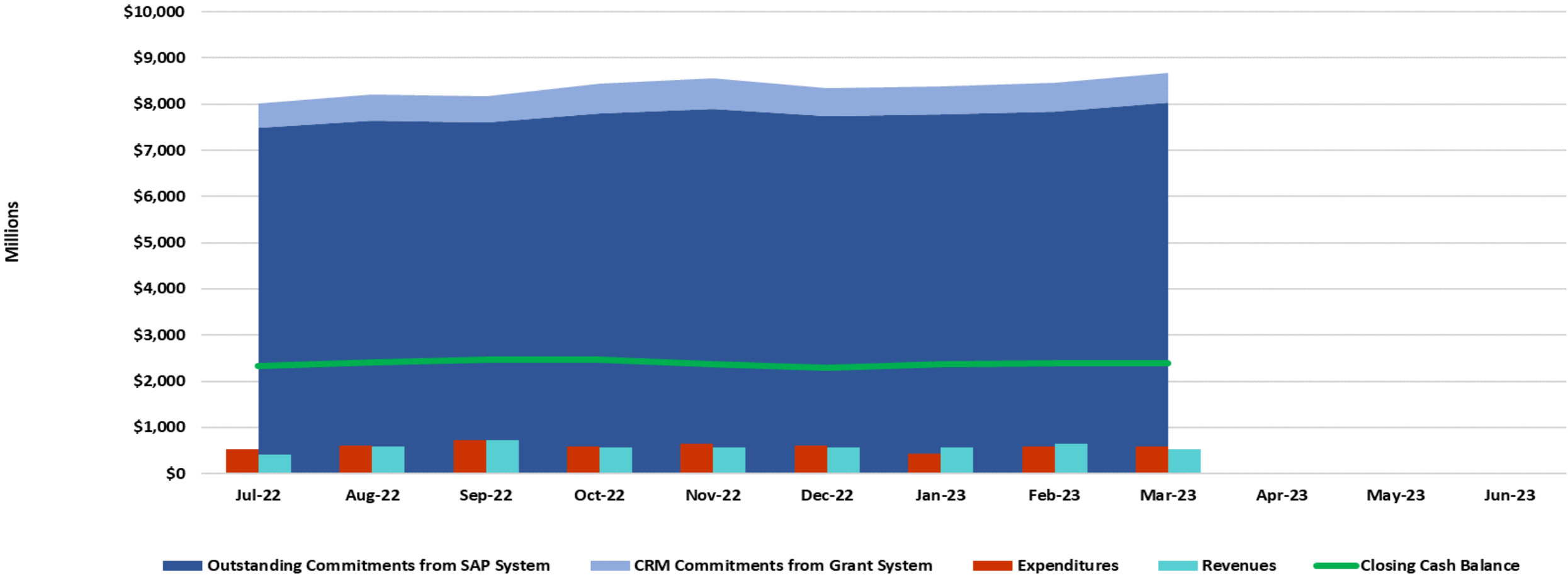

Cash Reporting

Joint Legislative Transportation Oversight Committee

March 2023 – Reporting Required

- N.C.G.S 143C-6-11(m) requires DOT to report each month when the department's combined average daily cash balance for the month is outside of the statutory target range.
- For March 2023, the **combined average daily cash balance** of the Highway Fund and the Highway Trust Fund was \$2.36 billion.
- The cash target amounts representing 15% and 20% of the total appropriations for the current fiscal year are \$716 million and \$955 million, respectively.
- The closing cash balance for March was \$2.40 billion which is above the target range and above the minimum cash balance requirement of \$358 million under N.C.G.S. 143C-6-11.

NCDOT Expenditures SFY2023 as of March 31, 2023

NCDOT Expenditures (\$M)

NCDOT External Payments (%)

- External Payments
- DOT Labor
- Vendor Payments
- Debt Service
- Transfers to Other Agencies
- Miscellaneous Service Contracts
- Equipment Purchases
- Not Assigned G/L Account (s)

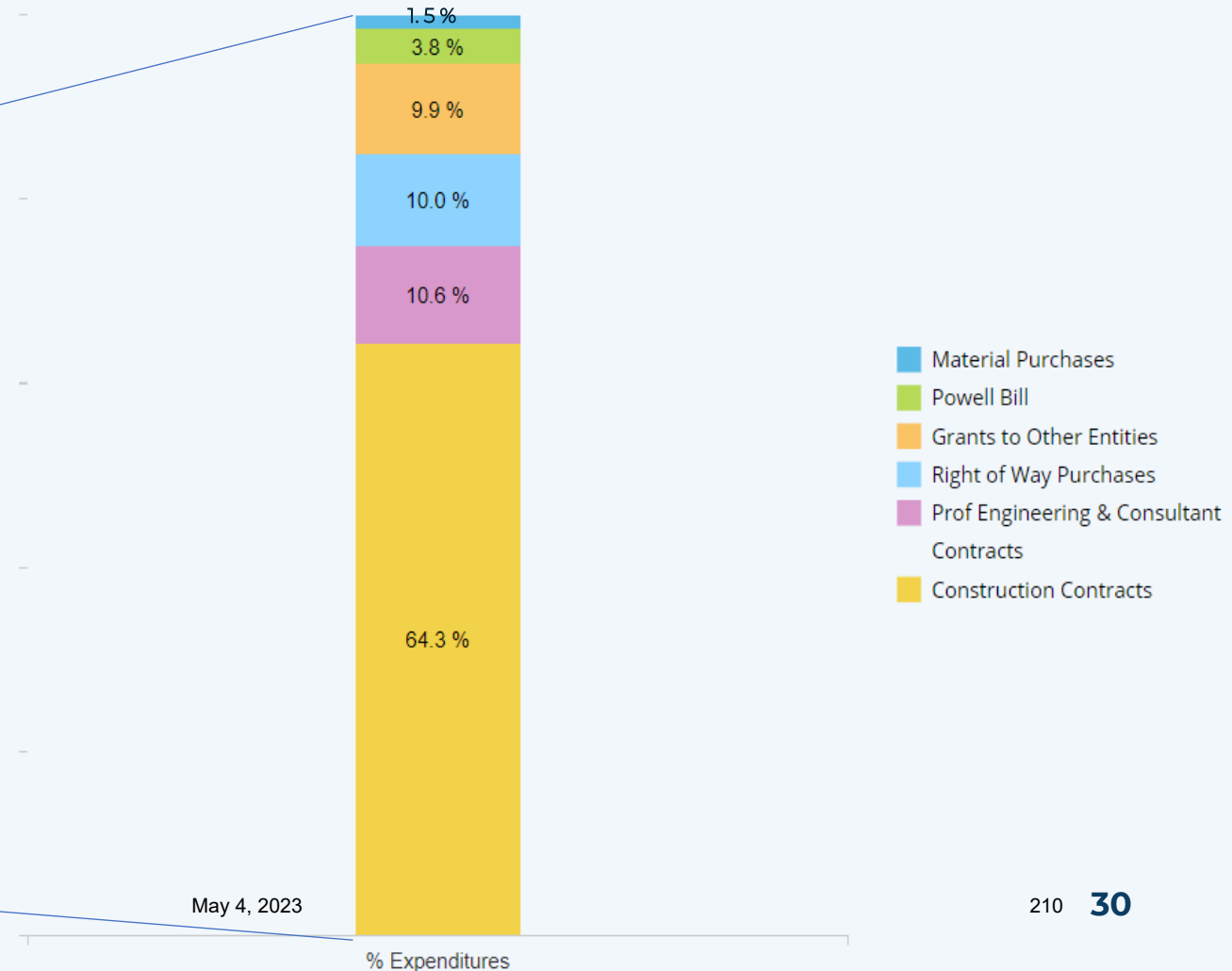
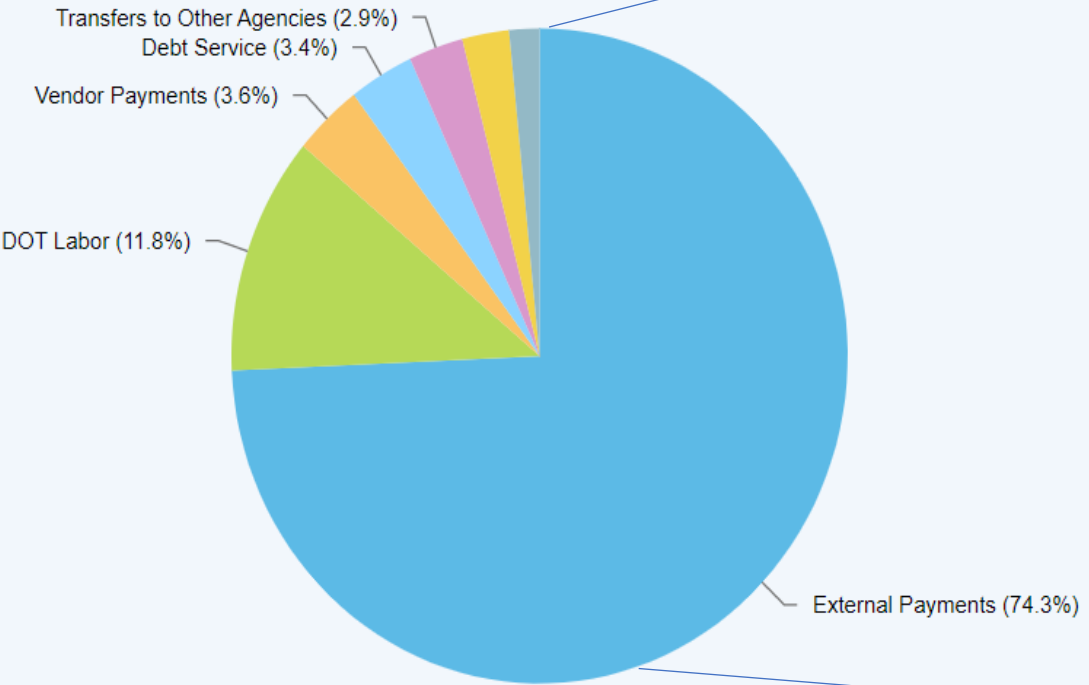

Budget versus Spend Plan through March

Highway Fund Programs
2022-23

	Carry Forward Authority										APPROVED 10/5/22			State & Other Total Spent thru 3/31/23	Federal Total Spent thru 3/31/23	Total Spent thru 3/31/23	Difference \$	Diff. %			
	SL 2022-74 Budget	SL 2021-180 Section 3.2	Credit Balance Legislation	FY22 Overdrafts Accounted By FY23 Approp Authority	Unexpended Allotments		Unallotted Appropriations		Carry Forward Authority	FY23 Cashflow Payback	FY24 Cashflow	Net FY23 Appropriations	Federal Carry Forward						State Spend Plan	Federal Spend Plan	Total Spend Plan
DOT-General Administration	\$ 117,732,373										117,732,373		\$ 116,982,373		\$ 116,982,373	74,860,288.58		74,860,288.58	\$ (42,122,084)	-36%	
Highway Division Administration	37,278,745										37,278,745		38,028,745		38,028,745	23,732,960.22		23,732,960.22	(14,295,785)	-38%	
Total Admin	\$ 155,011,118	\$ -									\$ 155,011,118	\$ -	\$ 155,011,118	\$ -	\$ 155,011,118	98,593,248.80		98,593,248.80	\$ -	(56,417,869)	-36%
Construction Program																					
Primary Construction-Cost Escalations	135,000,000										135,000,000		135,000,000		135,000,000	12,092,243.88		12,092,243.88	(122,907,756)	-91%	
State Secondary System	12,000,000		(22,610)	(152,521)	53,913,107	712,441	3,336,346		57,961,893		69,786,762		20,434,169		20,434,169	10,907,207.90	(a)	10,907,207.90	(9,526,961)	-47%	
Spot Safety Improvements	12,100,000			(1,580,063)	35,169,141				35,169,141		45,689,078		13,532,557		13,532,557	11,060,452.60		11,060,452.60	(2,472,104)	-18%	
Contingency Funds	12,000,000		(39,907)	(516,837)	39,519,245	1,054,060	67,960,250		108,533,555		119,976,811		10,015,306		10,015,306	10,653,023.23		10,653,023.23	637,717	6%	
Mobility Modernization	41,443,078		(485,348)	(52,529,947)	34,552,279	121,543,398	485,349		156,581,026		145,008,808		447,185,755		447,185,755	334,021,459.82	(j)	334,021,459.82	(113,184,295)	-25%	
Total Construction Program	\$ 212,543,078	\$ -	(547,865)	(54,779,368)	163,153,772	123,309,899	71,781,945		358,245,615		515,461,400		\$ 626,167,787	\$ -	\$ 626,167,787	378,734,387.43		378,734,387.43	\$ (247,433,400)	-40%	
Maintenance Program																					
General Maintenance Reserve	615,657,817			(3,199,190)	145,826,451	29,248,306	22,765,975	11,714,119	209,554,851	(181,989,911)	121,326,607		755,879,059		755,879,059	440,690,909.17		440,690,909.17	(315,188,150)	-42%	
Contract Resurfacing	570,599,527		(12,278)	(5,900,551)	683,615,639	1,332,482	4,237,890		689,186,011	(399,593,670)	376,588,816		604,036,876		604,036,876	414,159,348.68		414,159,348.68	(189,877,527)	-31%	
Bridge Program	275,167,830		(598,997)	(1,176,744)	493,650,859	2,889,883	16,553,607		513,094,350	(27,396,483)			330,490,315		330,490,315	204,273,420.20		204,273,420.20	(126,216,895)	-38%	
Bridge Preservation	69,899,551				36,278,884	(3,406)	4,951,433		41,226,910				98,365,000		98,365,000	66,155,430.29		66,155,430.29	(32,209,570)	-33%	
Roadside Environmental	117,177,694			(1,571,236)	11,267,312		945,186		12,212,497	(13,813,029)			112,337,219		112,337,219	94,935,115.40		94,935,115.40	(17,402,104)	-15%	
Pavement Preservation	85,358,348			(8,341,276)	113,760,197		10,390,554		124,150,751	(47,764,540)	44,405,272		107,007,265		107,007,265	73,904,711.51		73,904,711.51	(33,102,553)	-31%	
Total Maintenance Program	\$ 1,733,860,767	\$ -	(611,275)	(20,188,997)	1,484,399,343	33,467,264	59,844,645	11,714,119	1,589,425,371	(670,557,633)	542,320,695		\$ 2,008,115,734	\$ -	\$ 2,008,115,734	1,294,118,935.25		1,294,118,935.25	\$ (713,996,799)	-36%	

Budget versus Spend Plan through March

Highway Fund Programs

2022-23

	Carry Forward Authority											APPROVED 10/5/22			State & Other Total Spent thru 3/31/23	Federal Total Spent thru 3/31/23	Total Spent thru 3/31/23	Difference \$	Diff. %				
	SL 2022-74 Budget	SL 2021-180 Section 3.2	Credit Balance Legislation	FY22 Overdrafts Accounted By FY23 Approp Authority	Unexpended Allotments		Unallotted Appropriations		=+F+G+H+I	Carry Forward Authority	FY23 Cashflow Payback	FY24 Cashflow	Net FY23 Appropriations	Federal Carry Forward						State Spend Plan	Federal Spend Plan	Total Spend Plan	
Ferry Operations	57,897,653	-	-	-	(70,554)	72,997	-	175,244	177,687	-	-	58,075,340	248,241	58,453,727	-	58,453,727	44,602,093.70	3,446.26	44,605,539.96	(b) (l)	(13,848,187)	-24%	
Ferry Capital Fund	-	-	-	-	7,406,269	-	-	-	7,406,269	-	-	7,406,269	-	8,632,877	-	8,632,877	4,914,956.81	-	4,914,956.81	-	(3,717,920)	-43%	
State Aid to Municipalities	154,875,000	-	-	-	486,210	-	-	-	486,210	-	-	155,361,210	-	154,875,000	-	154,875,000	154,849,268.84	-	154,849,268.84	-	(25,731)	0%	
State Aid to Railroads	52,140,338	-	-	(693,462)	77,170,593	53,684,062	2,258,789	-	133,113,444	-	-	184,560,321	50,968,394	56,787,477	64,800,474	121,587,951	29,541,537.13	115,115.99	29,656,653.12	(c)	(91,931,298)	-76%	
Integrated Mobility Division	71,394,735	-	-	(1,481)	54,067,388	129,885,980	-	12,582,280	196,535,648	-	-	267,928,902	136,894,617	61,033,826	63,966,174	125,000,000	60,996,205.72	50,237,118.22	111,233,323.94	-	(13,766,676)	-11%	
Airports	209,774,816	-	(1)	-	129,308,813	27,922,949	1	22,136,950	179,368,713	-	-	389,143,530	50,129,899	197,439,019	20,847,930	218,286,949	163,537,889.82	24,169,665.13	187,707,554.95	(k)	(30,579,394)	-14%	
OSHA Program	358,030	-	-	(399)	491,078	-	22,720	-	513,798	-	-	871,429	-	358,030	-	358,030	297,184.88	-	297,184.88	-	(60,845)	-17%	
Governor's Highway Safety Program	305,546	-	-	-	5,601	14,483,495	153,237	29,569,691	44,212,023	-	-	44,517,569	44,052,837	305,546	13,500,000	13,805,546	336,224.27	10,990,841.96	11,327,066.23	-	(2,478,480)	-18%	
Division of Motor Vehicles	152,428,637	-	-	-	-	-	-	-	-	-	-	152,428,637	-	152,428,637	70,000	152,498,637	106,434,365.14	-	106,434,365.14	-	(46,064,272)	-30%	
Performance Energy Debt	-	-	-	-	-	-	-	-	-	-	-	-	-	-	-	-	273,250.00	-	273,250.00	-	273,250	0%	
Non-System Streets	-	-	-	-	-	15,207,725	-	-	15,207,725	-	-	15,207,725	-	-	-	-	4,858,792.65	-	4,858,792.65	-	4,858,793	-	
MCSAP/DMV Grants	2,196,571	-	-	-	677,274	10,440,024	2,788,172	10,943,471	24,848,941	-	-	27,045,512	21,383,495	2,196,571	-	2,196,571	305,650.61	717,417.44	1,023,068.05	-	(1,173,503)	-53%	
N.C.G.S 147-88.15 Cash Management	-	-	-	-	-	-	-	-	-	-	-	-	-	-	-	(205,000,000)	(205,000,000)	-	(205,000,000)	-	(300,000)	0%	
Total Misc	701,371,328	-	(1)	(695,342)	269,542,672	251,697,233	5,222,919	75,407,635	601,870,459	-	-	1,302,546,444	303,677,483	487,510,710	163,184,578	650,695,288	365,647,419.57	86,233,605.00	451,881,024.57	-	(121,863,290)	-19%	
Transfers to Other State Agencies	-	-	-	-	-	-	-	-	-	-	-	-	-	-	-	-	-	-	-	-	-	-	-
Emergency Reserve per SL2019-251	-	-	-	-	-	-	-	-	-	-	-	-	-	-	-	-	-	-	-	-	-	-	-
Agriculture	5,977,526	-	-	-	-	-	-	-	-	-	-	5,977,526	-	5,977,526	-	5,977,526	4,901,782.00	-	4,901,782.00	-	(1,075,744)	-18%	
Revenue	6,091,861	-	-	-	-	-	-	-	-	-	-	6,091,861	-	6,091,861	-	6,091,861	3,373,044.60	-	3,373,044.60	-	(2,718,816)	-45%	
OSC-BEST	557,395	-	-	-	-	-	-	-	-	-	-	557,395	-	557,395	-	557,395	453,384.25	-	453,384.25	-	(104,011)	-19%	
State Ethics Commission	56,816	-	-	-	-	-	-	-	-	-	-	56,816	-	56,816	-	56,816	59,688.99	-	59,688.99	-	2,873	5%	
OSBM-Oversight Manager	163,384	-	-	-	-	-	-	-	-	-	-	163,384	-	163,384	-	163,384	99,935.25	-	99,935.25	-	(63,449)	-39%	
Commerce - Econ Dev Liaison	(160,000)	-	-	-	-	-	-	-	-	-	-	(160,000)	-	(160,000)	-	(160,000)	(160,000.00)	-	(160,000.00)	-	(160,000)	-	
DHHS - Chemical Test	674,363	-	-	-	-	-	-	-	-	-	-	674,363	-	674,363	-	674,363	519,416.00	-	519,416.00	-	(154,947)	-23%	
Total Transfers to Other State Agencies	\$ 13,361,345	\$ -	\$ -	\$ -	\$ -	\$ -	\$ -	\$ -	\$ -	\$ -	\$ -	\$ 13,361,345	\$ -	\$ 13,521,345	\$ -	\$ 13,521,345	\$ 9,247,251.09	\$ -	\$ 9,247,251.09	\$ -	\$ (4,274,094)	\$ -32%	

Budget versus Spend Plan through March

Highway Fund Programs

2022-23

	G.S. 136-44.2 (f) (1-4)		G.S. 136-16.10		Unexpended Allotments		Unallotted Appropriations		Carry Forward Authority		=+F+G+H+I		APPROVED 10/5/22			State & Other Total Spent thru 3/31/23	Federal Total Spent thru 3/31/23	Total Spent thru 3/31/23	Difference \$	Diff. %	
	SL 2022-74 Budget	SL 2021-180 Section 3.2	Credit Balance Legislation	FY22 Overdrafts Accounted By FY23 Approp Authority	State	Other	State	Other	Carry Forward Authority	FY23 Cashflow Payback	FY24 Cashflow	Net FY23 Appropriations	Federal Carry Forward	State Spend Plan	Federal Spend Plan						Total Spend Plan
Reserves																					
Minority Contractor Development	150,000				296,535				296,535		446,535			150,000		150,000				(150,000)	-100%
State Fire Protection Grant	158,000										158,000			158,000		158,000	158,000.00		158,000.00		0%
Stormwater Discharge Permit	500,000				2,706,769				2,706,769		3,206,769			500,000		500,000				(500,000)	-100%
Global Transpark	8,862,833										8,862,833			8,862,833		8,862,833	6,647,124.00		6,647,124.00	(2,215,709)	-25%
Admin Reduction	(581,441)										(581,441)			(581,441)		(581,441)				581,441	-100%
Salary Adjustment Fund	6,896,387										6,896,387			6,896,387		6,896,387				(6,896,387)	-100%
Reserve for Call Center Consolidations	556,074										556,074			556,074		556,074				(556,074)	-100%
Reserve for Legislative Increase	26,710,425										26,710,425			26,710,425		26,710,425				(26,710,425)	-100%
Reserve for State Health Plan	6,062,824										6,062,824			6,062,824		6,062,824				(6,062,824)	-100%
Short Term Disability	-										-			-		-				-	-
Employer's Contribution to Retirement	8,800,548										8,800,548			8,800,548		8,800,548				(8,800,548)	-100%
Total Reserves	\$ 58,115,650	\$ -			3,003,304				3,003,304		61,118,954			\$ 58,115,650	\$ -	\$ 58,115,650	6,805,124.00		6,805,124.00	\$ (51,310,526)	-88%
Total Current Operations	2,874,263,286		(1,159,141)	(75,663,707)	1,920,099,090	408,474,396	136,849,509	87,121,755	2,552,544,750	(670,557,633)	542,320,695	5,221,748,249	303,677,483	3,348,442,344	163,184,578	3,511,626,922	2,153,146,366.14	86,233,605.00	2,239,379,971.14	(1,195,295,978)	
Capital Improvements	10,409,756			(31,558)	46,342,543		344,809		46,687,351		57,065,550			3,543,972		3,543,972	2,216,947.02		2,216,947.02 (d)	(1,327,025)	-37%
STIP/Right of Way Acquisition Transfer	109,834,972										109,834,972			109,834,972		109,834,972				(109,834,972)	-100%
Total Highway Fund Appropriation	\$ 2,994,508,014	\$ -	(1,159,141)	(75,695,265)	\$ 1,966,441,633	\$ 408,474,396	\$ 137,194,317	\$ 87,121,755	\$ 2,599,232,101	\$ (670,557,633)	\$ 542,320,695	\$ 5,388,648,771	\$ 303,677,483	\$ 3,461,821,288	\$ 163,184,578	\$ 3,625,005,866	2,155,363,313.16	86,233,605.00	2,241,596,918.16	\$ (1,306,457,975)	

Budget versus Spend Plan through March

Trust Fund Programs 2022-23	G.S. 136-186 (f)		Unexpended Allotments		Unallotted Appropriations		Carry Forward Authority	FY23 Cashflow Payback	FY24 Cashflow	Net FY23 Appropriations	Federal Carry Forward	State Spend Plan	Federal Spend Plan	Total Spend Plan	State & Other Total Spent thru 3/31/23	Federal Total Spent thru 3/31/23	Total Spent thru 3/31/23	Difference \$	Difference %	
	SL 2022-74 Budget	Credit Balance Legislation	FY22 Overdrafts Accounted By FY23 Approp Authority	State	Other	State														Other
Program Administration	\$ 39,433,938		-				-			39,433,938		\$ 37,900,919		37,900,919	25,499,736.59		25,499,736.59	\$ (12,401,182)	-33%	
Bond Redemption	52,290,000		-				-			52,290,000		67,824,474		67,824,474	-		-	(67,824,474)	-100%	
Bond Interest	40,757,650		-				-			40,757,650		53,618,178		53,618,178	26,809,088.75		26,809,088.75	(26,809,089)	-50%	
Tumpline Authority	49,000,000		-				-			49,000,000		49,000,000		49,000,000	36,750,000.00		36,750,000.00	(12,250,000)	-25%	
State Ports Authority	45,000,000		-				-			45,000,000		45,000,000		45,000,000	33,750,000.00		33,750,000.00	(11,250,000)	-25%	
FHWA State Match	5,104,440			34,152,049		13,154,890		47,306,939		52,411,379		5,104,440		5,104,440	9,920,070.04		9,920,070.04	4,815,630	94%	
Transfer to Visitor Center	640,000		-				-			640,000		640,000		640,000	-		-	(640,000)	-100%	
Strategic Prioritization & Other Capital Programs	1,603,273,972	(250,000)	(70,728,890)	4,285,313,578	3,529,038,253	187,914,327	4,508,782,817	12,511,048,975	(1,104,511,093)	1,883,287,263	14,822,120,228	7,946,801,184	1,603,273,972	2,199,600,546	3,802,874,518	1,696,873,725.47	1,045,116,936.44	2,741,990,661.91	(1,060,883,856)	-28%
N.C.G.S 147-86.15 Cash Management												205,000,000		205,000,000	205,300,000.00		205,300,000.00	300,000	0%	
STIP/Right of Way Acquisition Transfer												(109,834,972)		(109,834,972)	-		-	109,834,972	-100%	
NCTA Loan												100,000,000		100,000,000	10,537.83		10,537.83	(99,989,462)	-100%	
Total Trust Fund Appropriation	\$ 1,835,500,000	\$ (250,000)	\$ (70,728,890)	\$ 4,319,465,627	\$ 3,529,038,253	\$ 201,069,217	\$ 4,508,782,817	\$ 12,558,355,914	\$ (1,104,511,093)	\$ 1,883,287,263	\$ 15,101,653,195	\$ 7,946,801,184	\$ 2,057,527,011	\$ 2,199,600,546	\$ 4,257,127,557	2,034,913,158.68	1,045,116,936.44	3,080,030,095.12	\$ (1,177,097,461)	
	\$ 4,830,008,014	\$ (1,409,141)	\$ (146,424,154)	\$ 6,285,907,260	\$ 3,837,512,649	\$ 338,263,535	\$ 4,595,904,571	\$ 15,157,588,015	\$ (1,775,068,726)	\$ 2,425,607,958	\$ 20,490,301,966	\$ 8,250,478,667	\$ 5,519,348,299	\$ 2,362,785,124	\$ 7,882,133,422	4,190,276,471.84	1,131,350,541.44	5,321,627,013.28	\$ (2,483,555,436)	

- (a) Actuals for Secondary Construction from the Trust Fund are included
- (b) Ferry Capital Fund carry forward authority includes funds transferred from Ferry Operations as required by G.S. 136-82 (h).
- (c) Actuals for Railroad Program from the Highway Trust Fund are included
- (d) Actuals for Capital Improvement from the Highway Trust Fund are included, will also include expenditures from the State Capital Infrastructure Fund
- (e) Capital Program includes both the Highway Trust Fund and FHWA Funds in the Highway Fund
- (f) Carry Forward Authority includes state funding, federal grants and local participation funding.
- (g) Other Funds includes local participation and federal grants.
- (h) GMR carry forward authority includes funding from programs such as LOGO and TODS.
- (i) FHWA State Match expenditures include HPR/SPR state match and STI state match.
- (j) Mobility Modernization expenditures and Spend Plan includes \$59,500,000 in Dept. of Commerce funds.
- (k) Aviation expenditures and Spend Plan include \$11,500,000 in General Fund Capital and Infrastructure Fund for Directed Grants to Airports
- (l) Ferry expenditures and spend plan include \$556,074 in call center consolidation reserve funds.

Contingency Carry Forward includes unexpended Cash Flow requested by Legislature for the Glen Laurel Road Project, currently in the second year of an anticipated 3 year project.

SFY 23 Approved Spend Plan Versus Adjusted Spend Plan

	Jul-22	Aug-22	Sep-22	Oct-22	Nov-22	Dec-22	Jan-23	Feb-23	Mar-23	Apr-23	May-23	Jun-23	Jul-23	Aug-23	Sep-23	Oct-23	Nov-23	Dec-23	18 Month Adjusted Workplan July 22 - Dec. 23	Approved 10/5/22	Work Plan July 22 - Dec. 23	Delta
	1	2	3	4	5	6	7	8	9	10	11	12	13	14	15	16	17	18				
OPENING CASH BALANCE	\$ 2,377	\$ 2,325	\$ 2,406	\$ 2,459	\$ 2,473	\$ 2,380	\$ 2,294	\$ 2,377	\$ 2,394	\$ 2,399	\$ 2,373	\$ 2,168	\$ 2,046	\$ 1,929	\$ 1,803	\$ 1,642	\$ 1,633	\$ 1,497				
REVENUES																						
State revenues	358	385	398	373	360	377	381	371	390	390	387	408	391	408	393	380	371	352	6,873	\$ 6,907	(34)	
Federal aid	39	145	234	71	99	118	86	244	75	159	161	157	58	133	143	89	107	81	2,200	2,200	0	
Federal aid - USDOT Discretionary Grant	1	2	1	1	1	2	1	4	3	5	4	3	0	5	5	0	6	6	52	30	22	
Turnpike Federal Aid	(0)	(0)	(0)	-	-	0	-	0	24	-	-	-	-	-	-	-	-	-	24	(0)	24	
Sales Tax	-	-	-	-	54	-	52	-	-	51	-	51	-	-	-	102	-	-	309	293	16	
Other	3	9	16	61	18	21	16	(10)	(2)	67	14	13	11	13	18	11	12	10	300	520	(219)	
	401	540	649	506	531	518	536	609	488	672	566	632	460	560	559	583	496	449	9,759	9,950	(192)	
BOND PROCEEDS/GARVEE	-	13	20	21	9	21	13	9	11	5	10	11	5	5	4	5	5	4	171	\$ 170	2	
BUILDNC REIMBURSEMENT FROM TRUSTEE	9	27	51	37	18	24	15	19	22	34	20	18	19	15	12	4	3	-	347	346	1	
TOTAL REVENUES & OTHER RECEIPTS	\$ 410	\$ 581	\$ 719	\$ 563	\$ 558	\$ 563	\$ 565	\$ 637	\$ 521	\$ 712	\$ 596	\$ 662	\$ 485	\$ 580	\$ 576	\$ 592	\$ 503	\$ 453	\$ 10,277	\$ 10,466	(189)	
CONSTRUCTION EXPENDITURES																						
Garvee Expenditures	0	(54)	(20)	(28)	(22)	11	(15)	(23)	(15)	(38)	(43)	(45)	(44)	(38)	(39)	(33)	(38)	(35)	(519)	\$ (818)	299	
Garvee Debt Service	-	(25)	0	-	(0)	0	-	(129)	-	-	-	-	-	(22)	-	-	-	-	(177)	(177)	0	
Division of Mitigation Services (Formerly EEP)	(0)	(0)	(0)	(0)	(0)	(0)	(0)	(0)	(0)	(7)	-	-	(6)	-	-	(4)	-	-	(17)	(33)	16	
BUILDNC Expenditures	(48)	(51)	(50)	(53)	(65)	(72)	(32)	(51)	(64)	(44)	(39)	(43)	(41)	(43)	(40)	(38)	(33)	(28)	(835)	(831)	(5)	
BUILDNC Debt Service	-	-	-	-	(27)	-	-	-	-	-	(95)	-	-	-	-	-	(26)	-	(147)	(147)	0	
STIP Construction - SAS	(103)	(170)	(132)	(154)	(140)	(99)	(121)	(99)	(121)	(89)	(97)	(107)	(113)	(129)	(137)	(132)	(125)	(111)	(2,175)	(1,957)	(217)	
NC Mobility Fund	0	(0)	(0)	(0)	(0)	(0)	(0)	(0)	(0)	-	-	-	-	-	-	-	-	-	(0)	0	(0)	
STIP Preconstruction & Holdouts	(85)	(3)	(116)	(28)	(47)	(91)	(54)	(43)	(96)	(185)	(145)	(154)	(139)	(146)	(137)	(135)	(135)	(126)	(1,890)	(1,890)	26	
TIP - USDOT Discretionary Grant	(28)	(17)	(28)	(17)	(18)	(28)	(12)	(9)	(24)	(15)	(17)	(9)	(11)	(10)	(10)	(10)	(10)	(11)	(285)	(305)	20	
Turnpike Authority	(0)	(1)	(1)	(0)	(1)	(10)	(0)	(15)	(19)	(0)	(0)	(0)	(0)	(0)	(0)	(0)	(0)	(0)	(47)	(3)	(44)	
Internal Orders	(6)	13	(6)	(2)	6	4	(14)	1	(6)	(1)	(1)	(1)	(1)	(1)	(1)	(1)	(1)	(1)	(20)	(9)	(11)	
Congestion Mitigation & Air Quality (CMAQ)	(4)	(2)	(3)	(2)	(2)	(5)	(1)	(1)	(1)	(3)	(3)	(3)	(3)	(3)	(3)	(3)	(3)	(3)	(43)	(46)	2	
Total Construction	\$ (274)	\$ (309)	\$ (356)	\$ (284)	\$ (315)	\$ (289)	\$ (250)	\$ (369)	\$ (345)	\$ (381)	\$ (439)	\$ (362)	\$ (358)	\$ (392)	\$ (367)	\$ (355)	\$ (370)	\$ (314)	\$ (6,130)	(6,216)	86	
MAINTENANCE EXPENDITURES																						
Other Construction - Secondary Roads	(1)	(1)	(2)	(2)	(1)	(2)	(1)	(1)	(1)	(4)	(3)	(3)	(1)	(1)	(1)	(1)	(1)	(1)	(27)	(27)	0	
Other Construction - Spot Safety Improvements	(1)	(1)	(1)	(1)	(2)	(1)	(1)	(2)	(2)	(1)	(1)	(1)	(1)	(1)	(1)	(1)	(1)	(1)	(20)	(20)	0	
Other Construction - Contingency	(2)	(2)	(0)	(3)	(2)	1	(1)	(1)	(1)	(0)	(0)	(1)	(1)	(1)	(1)	(1)	(1)	(1)	(18)	(16)	(2)	
Other Construction - Mobility/Modernization	(64)	(36)	(39)	(47)	(33)	(30)	(24)	(31)	(30)	(37)	(41)	(36)	(4)	(4)	(3)	(4)	(4)	(3)	(469)	(469)	0	
General Maintenance Reserve	(35)	(44)	(43)	(46)	(39)	(38)	(42)	(47)	(53)	(60)	(64)	(86)	(38)	(45)	(36)	(38)	(30)	(28)	(810)	(810)	0	
Contract Resurfacing	(75)	(69)	(71)	(46)	(61)	(37)	(17)	(13)	(25)	(69)	(65)	(57)	(83)	(86)	(69)	(56)	(30)	(12)	(939)	(939)	0	
Roadside Environmental	(8)	(15)	(15)	(13)	(13)	(9)	(8)	(7)	(7)	(4)	(5)	(9)	(8)	(9)	(9)	(10)	(11)	(8)	(167)	(167)	0	

SFY 23 Approved Spend Plan Versus Adjusted Spend Plan

Pavement Preservation	(4)	(15)	(15)	(15)	(16)	(2)	(1)	(2)	(4)	(10)	(13)	(10)	(17)	(13)	(13)	(13)	(5)	(2)	(169)	(169)	0
Bridge Program	(22)	(24)	(22)	(23)	(26)	(21)	(20)	(22)	(25)	(45)	(40)	(41)	(33)	(44)	(44)	(46)	(45)	(33)	(575)	(575)	0
Bridge Preservation	(6)	(10)	(8)	(7)	(6)	(7)	(6)	(7)	(8)	(9)	(11)	(12)	(9)	(10)	(7)	(9)	(8)	(5)	(147)	(147)	0
Emergency GMR	0	(1)	(3)	(3)	(4)	(9)	(9)	(9)	(4)	(21)	(13)	(18)	(0)	(1)	(1)	(3)	(4)	(13)	(116)	(116)	0
Disaster Funding - FEMA	(2)	(1)	(2)	(2)	(1)	0	(1)	(1)	(2)	(15)	(17)	(22)	(5)	(6)	(5)	(6)	(5)	(5)	(100)	(100)	0
Total Maintenance	\$ (220)	\$ (218)	\$ (222)	\$ (207)	\$ (204)	\$ (154)	\$ (131)	\$ (143)	\$ (162)	\$ (274)	\$ (273)	\$ (293)	\$ (199)	\$ (222)	\$ (192)	\$ (187)	\$ (145)	\$ (111)	\$ (3,557)	(3,555)	(2)
OTHER MODES																					
Integrated Mobility Division	(4)	(8)	(6)	(54)	(6)	(11)	(10)	(5)	(7)	(6)	(5)	(4)	(7)	(12)	(5)	(6)	(55)	(3)	\$ (213)	\$ (213)	0
Ferry Capital*	(2)	(1)	0	1	(1)	(0)	(1)	(1)	(1)	-	-	-	-	-	-	-	-	-	(5)	(9)	4
Ferry Division	(3)	(6)	(6)	(5)	(4)	(4)	(5)	(4)	(7)	(4)	(4)	(5)	(4)	(6)	(4)	(4)	(4)	(4)	(85)	(85)	0
Rail Division	(2)	(3)	(3)	(5)	(2)	(3)	(3)	(5)	(4)	(26)	(28)	(38)	(7)	(7)	(6)	(6)	(6)	(8)	(161)	(161)	0
Aviation Division	(4)	(13)	(7)	(11)	(76)	(34)	(12)	(13)	(19)	(4)	(4)	(23)	(8)	(8)	(33)	(8)	(6)	(28)	(308)	(308)	0
Total Other Modes	(15)	(30)	(21)	(75)	(89)	(52)	(30)	(28)	(37)	(40)	(41)	(69)	(26)	(32)	(48)	(24)	(72)	(44)	\$ (773)	(777)	4
OTHER EXPENDITURES																					
Administration	(19)	(26)	(27)	(24)	(29)	(24)	(24)	(26)	(32)	(41)	(33)	(39)	(16)	(46)	(31)	(33)	(38)	(19)	\$ (525)	\$ (560)	35
Transfers to Other State Agencies	(0)	(4)	(12)	(5)	(0)	(12)	(5)	(0)	(12)	-	-	(17)	-	-	(17)	-	-	(17)	(101)	(102)	1
Transfers to General Fund/NCTA/ER Fund	-	(12)	-	-	(12)	-	-	(12)	-	-	(12)	-	-	(12)	-	-	(12)	-	(74)	(74)	0
State aid to municipalities	-	-	(77)	-	-	(77)	-	-	-	-	-	-	-	-	(79)	-	-	(79)	(313)	(314)	0
Debt Service	-	-	-	-	-	-	-	-	-	-	-	-	-	-	-	-	-	-	-	-	0
Other Programs	(1)	(3)	(3)	(1)	(4)	(3)	(1)	(1)	(2)	(2)	(2)	(4)	(3)	(3)	(2)	(3)	(2)	(3)	(43)	(33)	(9)
Total Other Expenditures	\$ (20)	\$ (45)	\$ (119)	\$ (30)	\$ (46)	\$ (116)	\$ (29)	\$ (40)	\$ (46)	\$ (43)	\$ (48)	\$ (60)	\$ (19)	\$ (61)	\$ (129)	\$ (35)	\$ (52)	\$ (118)	\$ (1,056)	(1,082)	26
TOTAL EXPENDITURES	\$ (530)	\$ (603)	\$ (717)	\$ (597)	\$ (654)	\$ (611)	\$ (441)	\$ (580)	\$ (590)	\$ (739)	\$ (800)	\$ (784)	\$ (601)	\$ (706)	\$ (737)	\$ (602)	\$ (639)	\$ (587)	\$ (11,516)	\$ (11,630)	114
OTHER CHANGES IN CASH																					
N.C.G.S 147-86.15 Cash Management; Other Transfers																					
Highway Fund**	(40)	(50)	(30)	(30)	(25)	(30)	-	-	-	-	-	(109)	-	-	-	-	-	-	(314)		
Highway Trust Fund**	40	50	30	30	25	30	-	-	-	-	-	109	-	-	-	-	-	-	314		
Total Cash Management Transfers	-	-	-	-	-	-	-	-	-	-	-	-	-	-	-	-	-	-	-	-	-
Working capital changes	\$ 67	\$ 104	\$ 51	\$ 47	\$ 2	\$ (38)	\$ (41)	\$ (41)	\$ 75	\$ -	\$ -	\$ -	\$ -	\$ -	\$ -	\$ -	\$ -	\$ -			
	\$ 67	\$ 104	\$ 51	\$ 47	\$ 2	\$ (38)	\$ (41)	\$ (41)	\$ 75	\$ -	\$ -	\$ -	\$ -	\$ -	\$ -	\$ -	\$ -	\$ -			
NET CHANGE IN CASH	\$ (52)	\$ 82	\$ 53	\$ 13	\$ (93)	\$ (85)	\$ 83	\$ 17	\$ 5	\$ (27)	\$ (204)	\$ (123)	\$ (117)	\$ (126)	\$ (161)	\$ (9)	\$ (136)	\$ (134)			
CLOSING CASH BALANCE*	\$ 2,325	\$ 2,406	\$ 2,459	\$ 2,473	\$ 2,380	\$ 2,294	\$ 2,377	\$ 2,394	\$ 2,399	\$ 2,373	\$ 2,168	\$ 2,046	\$ 1,929	\$ 1,803	\$ 1,642	\$ 1,633	\$ 1,497	\$ 1,364			
CLOSING CASH BALANCE (HF & TF)	\$ 2,304																				

* Ferry Capital Expenditures related to encumbrance fund center - July \$1.5M
 **\$100M transfer from TF to Turnpike in October, Repayment in April 24
 **\$109M transfer from HF to TF for ROW in June 2023

Advance Construction

Funding Source	Unreimbursed Expenditures as of April 18, 2023	Apportionment in FY 2023**	Within Prescribed Limit?
National Highway Performance Program (NHPP)	\$126,986,681	\$772,579,357	YES
Surface Transportation Block Grant (STBG)*	\$67,283,057	\$375,849,417	YES
Highway Safety Improvement Program (HSIP)	\$48,056,395	\$80,520,985	YES

* Includes bridge replacement balance

** Allowable AC amount is annual FY 2023 Apportionment less Projected GARVEE Obligations

Advance Construction Balance as of March 2023

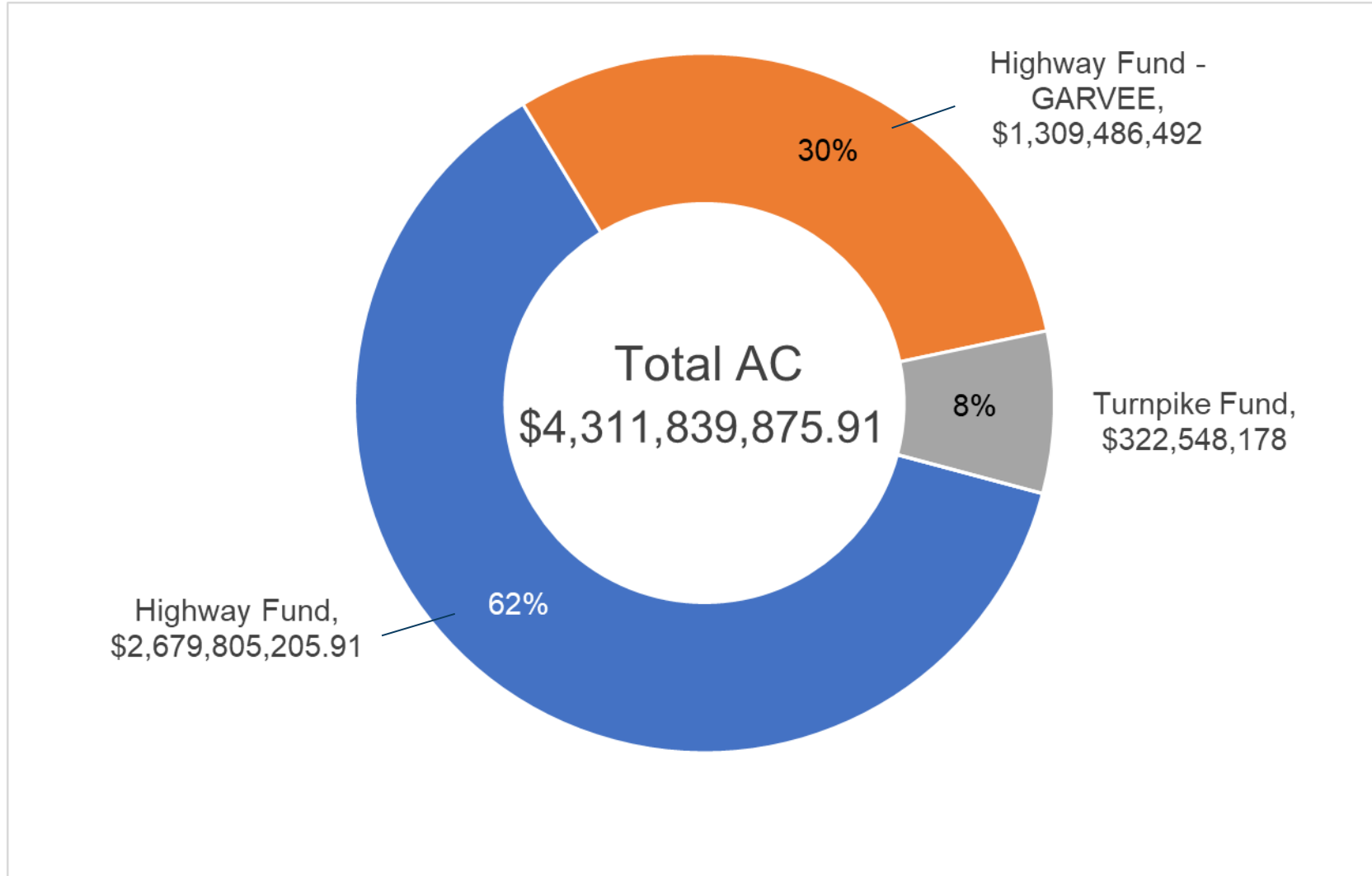

Advance Construction

Funding Source	AC Amount - April 18, 2023	Allowable AC amount FY 2023**	Within Prescribed Limit?
National Highway Performance Program (NHPP)	\$2,050,032,078	\$2,617,638,024	YES
Surface Transportation Block Grant (STBG)*	\$584,371,538	\$1,493,699,032	YES
Highway Safety Improvement Program (HSIP)	\$185,788,898	\$322,083,940	YES

* Includes bridge replacement balance

** Allowable AC amount is 4 times FY 2023 Apportionment less Projected GARVEE Obligations

Contact Us

Stephanie King

sjking@ncdot.gov



 @NCDOT

 NCDOT

 NCDOTcommunications

 @NCDOT

 ncdotcom

 ncdot_comm

Thank you!

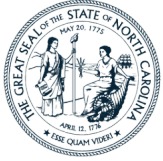

NORTH CAROLINA
Department of Transportation

SFY 2024-2025 Spend Plan

Michelle Ellis

Director of Forecasting and Spend Plan Management

Finance Committee Meeting

May 2023

Connecting people, products and places safely and efficiently with customer focus, accountability and environmental sensitivity to enhance the economy and vitality of North Carolina

Executive Summary

Financial Highlights

Proposed Spend Plan for SFY 2024

As part of the proposed Spend Plan, NCDOT is seeking to spend \$7,539 million in total expenditures for SFY 2024.

Proposed Spend Plan (\$ in millions)

	<u>Proposed Spend Plan</u>	
Revenues	7,169	
Garvee Reimbursement	41	
BuildNC	55	
Total Revenue	7,265	①
Construction	(4,349)	②
Maintenance Expenditures	(2,061)	③
Other Modes	(474)	④
Other Expenditures	(655)	⑤
Total Expenditures	(7,539)	
Working Capital Changes	100	
Net Change in Cash	(174)	
Ending Cash	1,782	

Proposed Spend Plan Line Detail

- ①** State Revenues as of 2/2023 by OSBM and NCDOT
Federal Aid as of 2/2023 by NCDOT
No Garvee or Build NC Issuance in 2024
- ②** Construction expenditures include preliminary engineering expenditures of \$295 million, right of way expenditures & utilities of \$665 million with the remainder for construction
- ③** Maintenance expenditures include contract resurfacing of \$572 million, General Maintenance Reserve of \$474 million, Bridge Program of \$275 million, \$158 million for disasters, other construction of \$306 million, pavement preservation of \$86 million, roadside environmental of \$119 million and bridge preservation of \$71 million.
- ④** Modes include IMD, Aviation, Ferry, and Rail of \$474 million
- ⑤** Other Expenditures of \$655 million including administration

Financial Highlights

Proposed Spend Plan for SFY 2025

As part of the proposed Spend Plan, NCDOT is seeking to spend \$7,918 million in total expenditures for SFY 2025.

Proposed Spend Plan (\$ in millions)	
	<u>Proposed Spend Plan</u>
Revenues	7,371
Garvee Reimbursement	9
BuildNC	227
Total Revenue	7,606 ①
Construction	(4,931) ②
Maintenance Expenditures	(1,848) ③
Other Modes	(446) ④
Other Expenditures	(692) ⑤
Total Expenditures	(7,918)
Working Capital Changes	-
Net Change in Cash	(312)
Ending Cash	1,471

Proposed Spend Plan Line Detail	
①	State Revenues as of 2/2023 by OSBM and NCDOT Federal Aid as of 2/2023 by NCDOT \$300m Garvee Issuance in 2025; \$300m Build NC Issuance
②	Construction expenditures include preliminary engineering expenditures of \$290 million, right of way expenditures & utilities of \$900 with the remainder for construction
③	Maintenance expenditures include contract resurfacing of \$572 million, General Maintenance Reserve of \$471 million, Bridge Program of \$275 million, \$161 million for disasters, other construction of \$93 million, pavement preservation of \$86 million, roadside environmental of \$119 million and bridge preservation of \$71 million.
④	Modes include IMD, Aviation, Ferry, and Rail of \$446 million
⑤	Other Expenditures of \$692 million including administration

Financial Highlights

The ending cash balance for SFY24 is estimated to be \$1,782 million and for SFY25 \$1,471 million.

Forecasted Ending Cash Balanced
(\$ in millions)

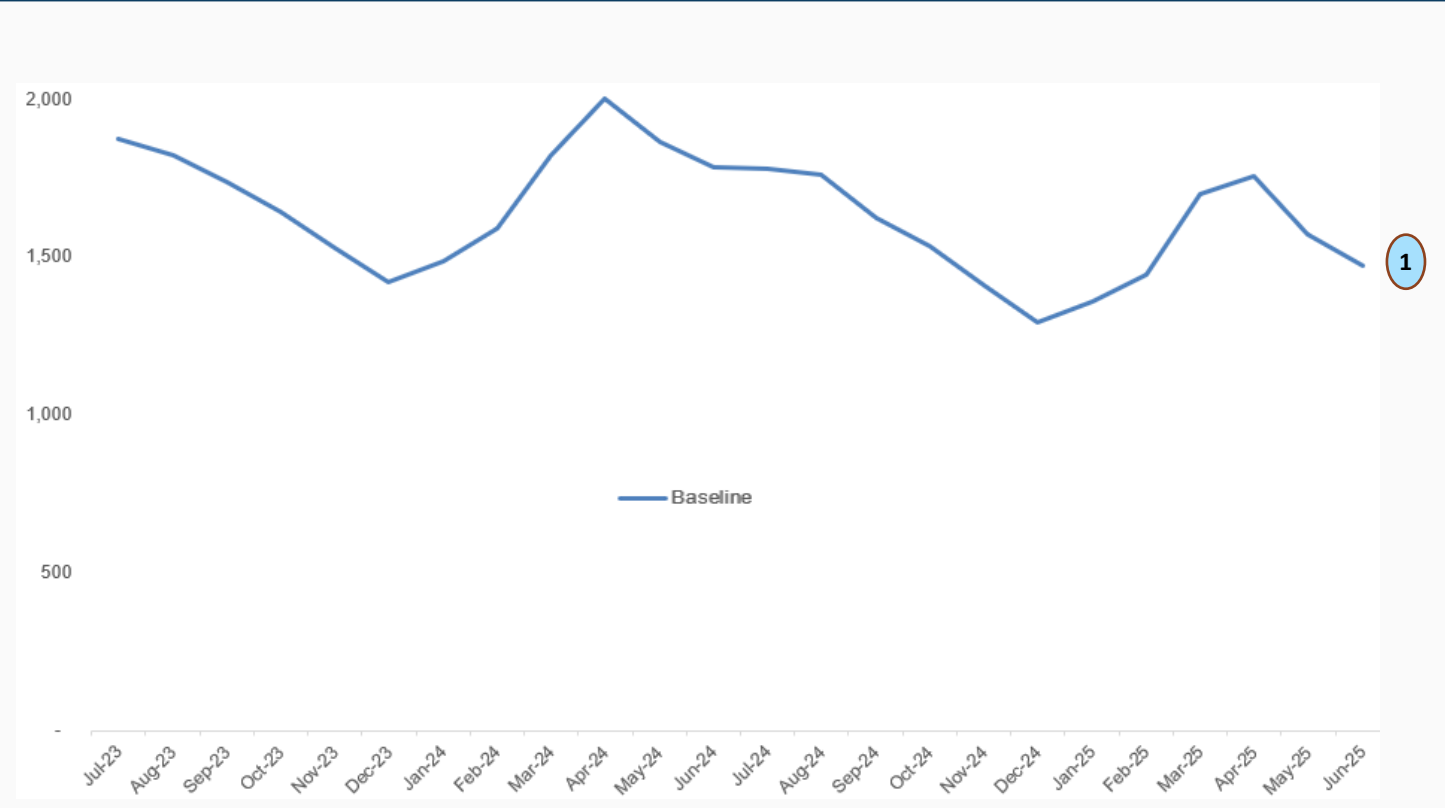

Proposed Spend Plan Line Detail

- 1 The proposed spend plan had a SFY24 ending cash balance of \$1,782 million and a SFY25 ending cash balance of \$1,471 million

2024 Detailed Line Items

Financial Highlights

Proposed Spend Plan for SFY 2024

Under NCDOT's proposed spend plan, totals revenues are estimated to be \$7,265 million.

Proposed Spend Plan on Forecasted Revenue

(\$ in millions)

Revenues	Proposed Spend Plan	
State revenues	4,740	①
Federal aid	1,548	②
Federal aid - US Discretionary Grant	50	③
Turnpike Federal Aid	-	
Sales Tax	420	④
Other	412	⑤
Total Revenue	7,169	
Trustee Reimbursements		
GARVEE Reimbursement	41	⑥
BuildNC Reimbursement	55	⑦
Total Trustee Reimbursements	96	
Total Revenue & Other Receipts	7,265	

Proposed Spend Plan Line Detail

- ① State Revenues as of 2/2023 by OSBM and NCDOT
- ② Federal Aid as of 2/2023 by NCDOT
- ③ Federal Aid US Discretionary Grants
- ④ General Fund Transfer of 4% of sales and use taxes
- ⑤ Other revenue includes Economic Development, Ferry Capital, Aviation State Capital, Rail, IMD, Damage Claims, GHSP, miscellaneous, and local & property owner income
- ⑥ No new issuance of GARVEE in SFY 2024
- ⑦ No new issuance of Build NC in SFY 2024

SFY 2024 Proposed Construction Expenditures

Construction expenditures were forecasted using SAS for the bulk of the program with \$4,082 million

Proposed Spend Plan on Forecasted Construction Expenditures

(\$ in millions)

Construction Expenditures	Proposed Spend Plan
Garvee Expenditures	(445) ①
Garvee Debt Service	(118)
BUILDNC Expenditures	(352) ②
BUILDNC Debt Service	(121)
STIP Preconstruction	(916) ③
STIP Construction & Holdouts	(2,268) ④
TIP - USDOT Discretionary Grant	(127)
Turnpike Authority	(2)
Total Construction Expenditures	(4,349)

Proposed Spend Plan Line Detail

- ① GARVEE expenditures of \$445 million with no new issuance planned in SFY 2024. These projects are using SAS forecasting.
- ② BUILD NC expenditures of \$352 million with no new issuance planned for SFY 2024. These projects are using SAS forecasting.
- ③ STIP Preconstruction expenditures of \$916 million include preliminary engineering of \$295 million and right of way & utilities of \$665 million less \$44 million for GARVEE & Build NC ROW projects.
- ④ STIP Construction & Holdout expenditures of \$2,268 million consist of \$1,689 million of construction expenditures. These projects are using SAS forecasting. The remaining \$579 million are construction holdouts not accounted for by project as they are most times not yet known.

SFY 2024 Proposed Maintenance Expenditure

Total proposed maintenance expenditures are \$2,061 million for the Proposed Spend Plan for SFY 2024

Proposed Spend Plan on Forecasted Maintenance Expenditures (\$ in millions)

Maintenance Expenditures	Proposed Spend Plan	
Other Construction - Secondary Roads	(12)	①
Other Construction - Spot Safety Improvement	(12)	
Other Construction - Contingency	(12)	
Other Construction - Mobility/Modernization	(41)	
Other Construction - Economic Development	(229)	
General Maintenance Reserve	(474)	②
Contract Resurfacing	(572)	③
Roadside Environmental	(119)	
Pavement Preservation	(86)	
Bridge Program	(275)	④
Bridge Preservation	(71)	
Emergency GMR	(91)	⑤
Disaster Funding - FEMA	(67)	
Total Maintenance Expenditures	(2,061)	

Proposed Spend Plan Line Detail

- ① Other construction of \$306 million includes Secondary Roads, Spot Safety, Contingency, Mobility/Modernization, and Economic Development
- ② General Maintenance Reserve expenditures are \$474 million
- ③ Contract Resurfacing is \$572 million
- ④ Bridge Program is \$275 million
- ⑤ Disaster Funding of \$158 million includes FEMA & Emergency GMR

SFY 2024 Proposed Other Modes Expenditure

Other Modes plans to spend \$474 million in SFY 2024

Proposed Spend Plan on Forecasted Other Modes Expenditures (\$ in millions)

Other Modes Expenditures	Proposed Spend Plan	
Integrated Mobility Division (Includes Federal)	(130)	①
Ferry Capital	-	②
Ferry Operations	(59)	③
Railroad program (Includes Federal)	(95)	④
Airports (Includes Federal)	(190)	⑤
Total Other Modes Expenditures	(474)	

Proposed Spend Plan Line Detail

- ① Integrated Mobility Division including Federal plans to spend \$130 million in SFY 2024
- ② Ferry Capital does not plan to spend in 2024
- ③ Ferry Operation plans to spend \$59 million.
- ④ Railroad programs plans to spend \$95 million
- ⑤ Aviation plans to spend \$190 million

SFY 2024 Proposed Other Expenditure

Other Expenditures of \$655 million are proposed to be spent in SFY 2024

Proposed Spend Plan on Forecasted Other Expenditures (\$ in millions)

Other Expenditures	Proposed Spend Plan
Administration	(363) ①
Transfers to Other State Agencies	(60)
Transfers to General & Emergency Fund/NCTA	(49)
State aid to municipalities	(155)
Debt Service	-
Other Programs	(27)
Total Other Expenditures	(655)

Proposed Spend Plan Line Detail

- ① Administration expenditures of \$363 million are expected to be spent

2025 Detailed Line Items

SFY 2025 Proposed Revenue

Revenue is projected to be \$7,606 million for SFY 2025.

Proposed Spend Plan on Forecasted Revenue (\$ in millions)	
Revenues	Proposed Spend Plan
State revenues	4,998 ①
Federal aid	1,521 ②
Federal aid - US Discretionary Grant	15 ③
Turnpike Federal Aid	-
Sales Tax	643 ④
Other	194 ⑤
Total Revenue	7,371
Trustee Reimbursements	
GARVEE Reimbursement	9 ⑥
BuildNC Reimbursement	227 ⑦
Total Trustee Reimbursements	236
Total Revenue & Other Receipts	7,606

Proposed Spend Plan Line Detail	
①	State Revenues as of 2/2023 by OSBM and NCDOT
②	Federal Aid as of 2/2023 by NCDOT
③	Federal Aid Discretionary Grants
④	General Fund Transfer of 6% of sales and use taxes
⑤	Other revenue includes Economic Development, Ferry Capital, Aviation State Capital, Rail, IMD, Damage Claims, GHSP, miscellaneous, and local & property owner income
⑥	\$300 million GARVEE issuance in SFY 2025
⑦	\$300 million Build NC issuance in SFY 2025

SFY 2025 Proposed Construction Expenditure Changes

Proposed Construction expenditures of \$4,931 million for SFY 2025

Proposed Spend Plan on Forecasted Construction Expenditures (\$ in millions)

Construction Expenditures	Proposed Spend Plan
Garvee Expenditures	(657) ①
Garvee Debt Service	(146)
BUILDNC Expenditures	(269) ②
BUILDNC Debt Service	(147)
STIP Preconstruction	(1,105) ③
STIP Construction & Holdouts	(2,495) ④
TIP - USDOT Discretionary Grant	(110)
Turnpike Authority	(2)
Total Construction Expenditures	(4,931)

Proposed Spend Plan Line Detail

- ① GARVEE expenditures of \$657 million with \$300 million issuance planned in SFY 2025. These projects are using SAS forecasting.
- ② BUILD NC expenditures of \$269 million with a new issuance planned for SFY 2025. These projects are using SAS forecasting.
- ③ STIP Preconstruction expenditures of \$1,105 million include preliminary engineering of \$290 million and right of way & utilities of \$900 million less \$85 million for GARVEE & Build NC ROW projects.
- ④ STIP Construction & Holdout expenditures of \$2,495 million consist of \$1,859 million of construction expenditures. These projects are using SAS forecasting. The remaining \$636 million are construction holdouts not accounted for by project as they are most times not yet known.

SFY 2025 Proposed Maintenance Expenditures

Maintenance Expenditures are projected to be \$1,848 million for SFY 2025

Proposed Spend Plan on Forecasted Maintenance Expenditures (\$ in millions)

Maintenance Expenditures	Proposed Spend Plan
Other Construction - Secondary Roads	(12) ①
Other Construction - Spot Safety Improvement	(12)
Other Construction - Contingency	(12)
Other Construction - Mobility/Modernization	(41)
Other Construction - Economic Development	(15)
General Maintenance Reserve	(471) ②
Contract Resurfacing	(572) ③
Roadside Environmental	(119)
Pavement Preservation	(86)
Bridge Program	(275) ④
Bridge Preservation	(71)
Emergency GMR	(94) ⑤
Disaster Funding - FEMA	(67)
Total Maintenance Expenditures	(1,848)

Proposed Spend Plan Line Detail

- ① Other construction of \$93 million includes Secondary Roads, Spot Safety, Contingency, Mobility/Modernization, and Economic Development
- ② General Maintenance Reserve expenditures are \$471 million
- ③ Contract Resurfacing is \$572 million
- ④ Bridge Program is \$275 million
- ⑤ Disaster Funding of \$161 million includes FEMA & Emergency GMR

SFY 2025 Proposed Other Modes Expenditure

Other Modes plans to spend \$446 million in SFY 2025

Proposed Spend Plan on Forecasted Other Modes Expenditures (\$ in millions)

Other Modes Expenditures	Proposed Spend Plan	
Integrated Mobility Division (Includes Federal)	(110)	①
Ferry Capital	-	②
Ferry Operations	(59)	③
Railroad program (Includes Federal)	(87)	④
Airports (Includes Federal)	(190)	⑤
Total Other Modes Expenditures	(446)	

Proposed Spend Plan Line Detail

- ① Integrated Mobility Division including Federal plans to spend \$110 million in SFY 2025
- ② Ferry Capital does not plan to spend any money in SFY 2025
- ③ Ferry Operation plans to spend \$59 million.
- ④ Railroad programs plans to spend \$87 million
- ⑤ Aviation plans to spend \$190 million

SFY 2025 Proposed Other Expenditure

Other Expenditures of \$692 million are proposed to be spent in SFY 2025

Proposed Spend Plan on Forecasted Other Expenditures (\$ in millions)

Other Expenditures	Proposed Spend Plan
Administration	(385) ①
Transfers to Other State Agencies	(64)
Transfers to General & Emergency Fund/NCTA	(49)
State aid to municipalities	(165)
Debt Service	-
Other Programs	(29)
Total Other Expenditures	(692)

Proposed Spend Plan Line Detail

① Administration expenditures of \$385 million are expected to be spent



NORTH CAROLINA
Department of Transportation

Revenue Reporting

NCDOT Financial Management

Michelle Ellis, Director of Forecasting and Spend Plan Management

May 3, 2023

Connecting people, products and places safely and efficiently with customer focus, accountability and environmental sensitivity to enhance the economy and vitality of North Carolina

Overall Revenue Performance Snapshot – Fiscal YTD

NCDOT has achieved 4,648m in revenue YTD, 1.4% above forecast

Revenue Commentary by Source

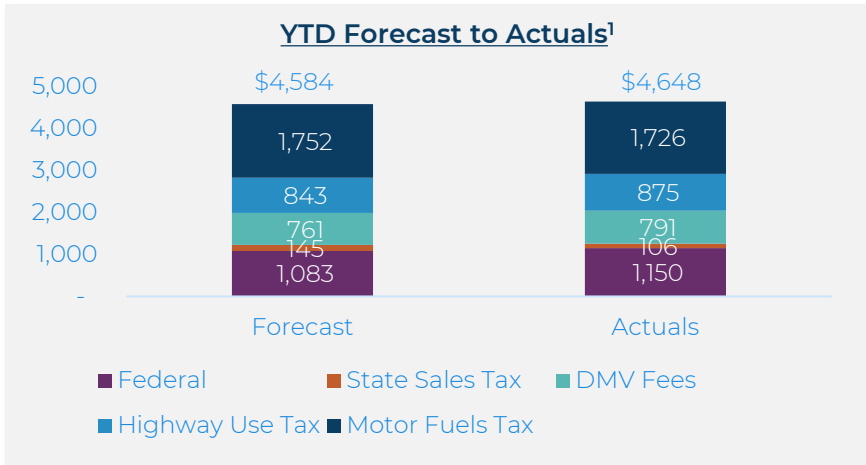



Motor Fuels Tax

- \$26m under forecast
- -0.6%



Highway Use Tax

- \$32m over forecast
- 3.8%



DMV Fees & Interest

- \$30m over forecast
- 3.9%



Sales Tax

- \$39m under forecast
- -26.7%



Federal Revenue

- \$67m over forecast
- 6.2%

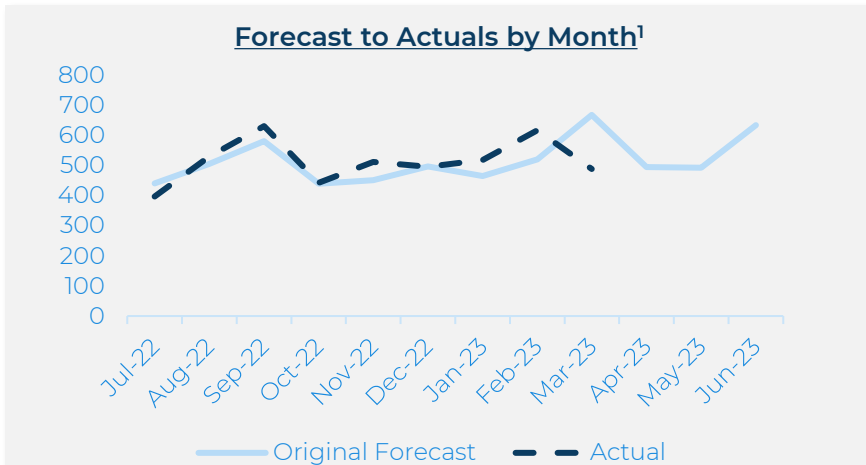

NCDOT Board of Transportation Meeting Minutes

May 4, 2023

1. \$ Millions, Excludes Trustee Reimbursements from Bonds and Other Revenues, Represents Certified Consensus State Revenue Comparisons

Highway Fund Revenue Performance Snapshot – Fiscal YTD

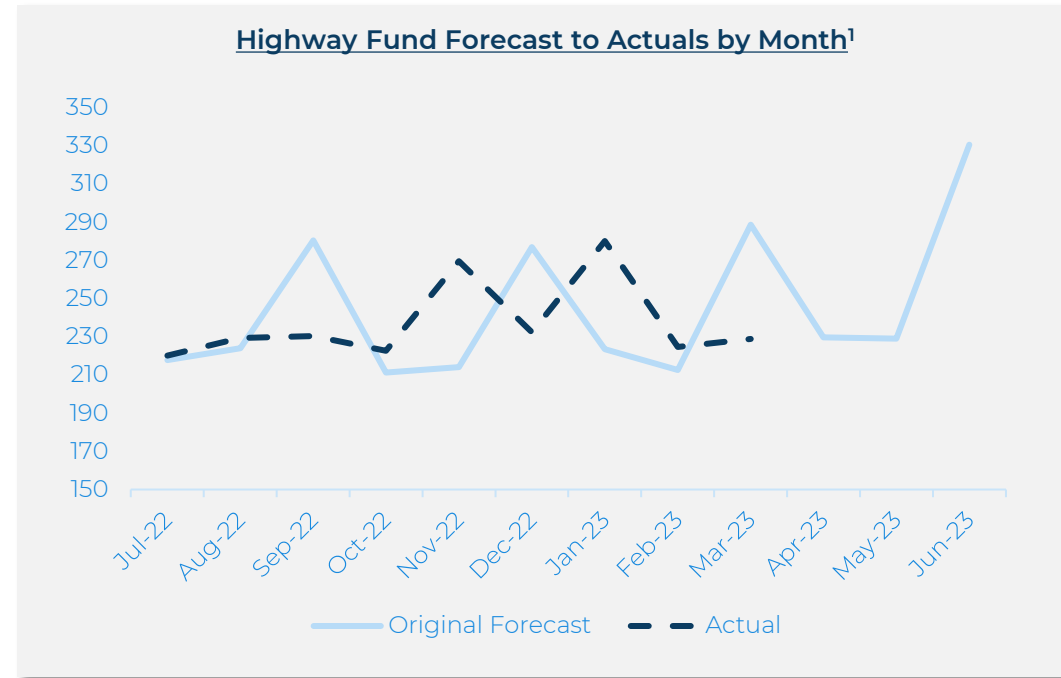
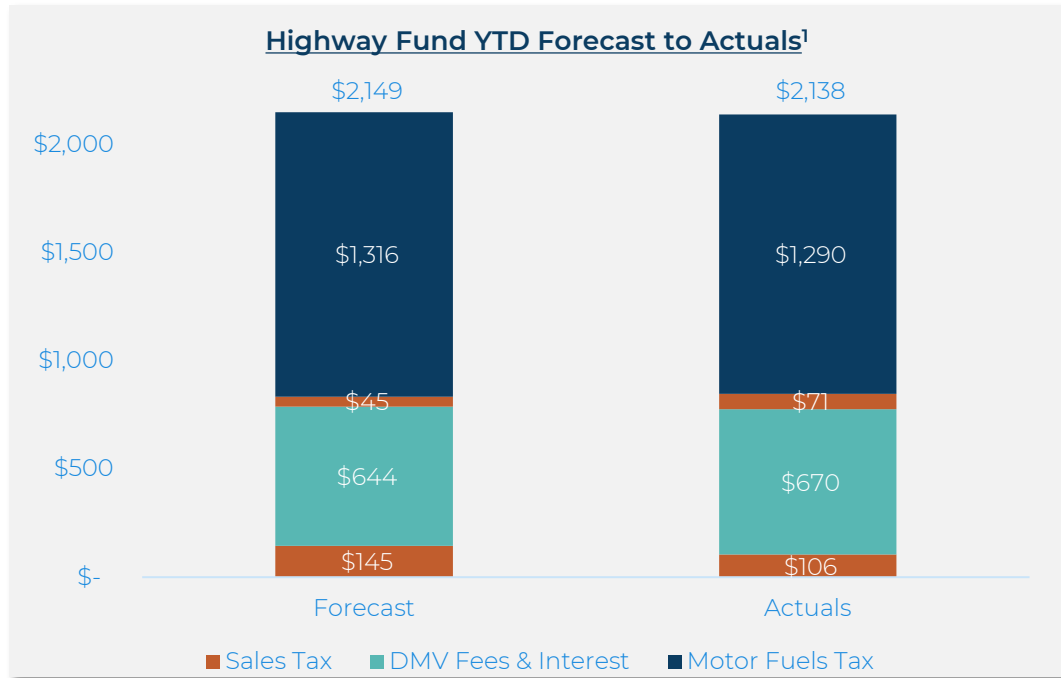

Highway Fund Revenue Commentary

- Total revenue of \$2,138m YTD which represents 46% of total NCDOT revenue and is currently 0.5% above forecast

1. \$ Millions, excludes federal revenues

Trust Fund Revenue Performance Snapshot – Fiscal YTD

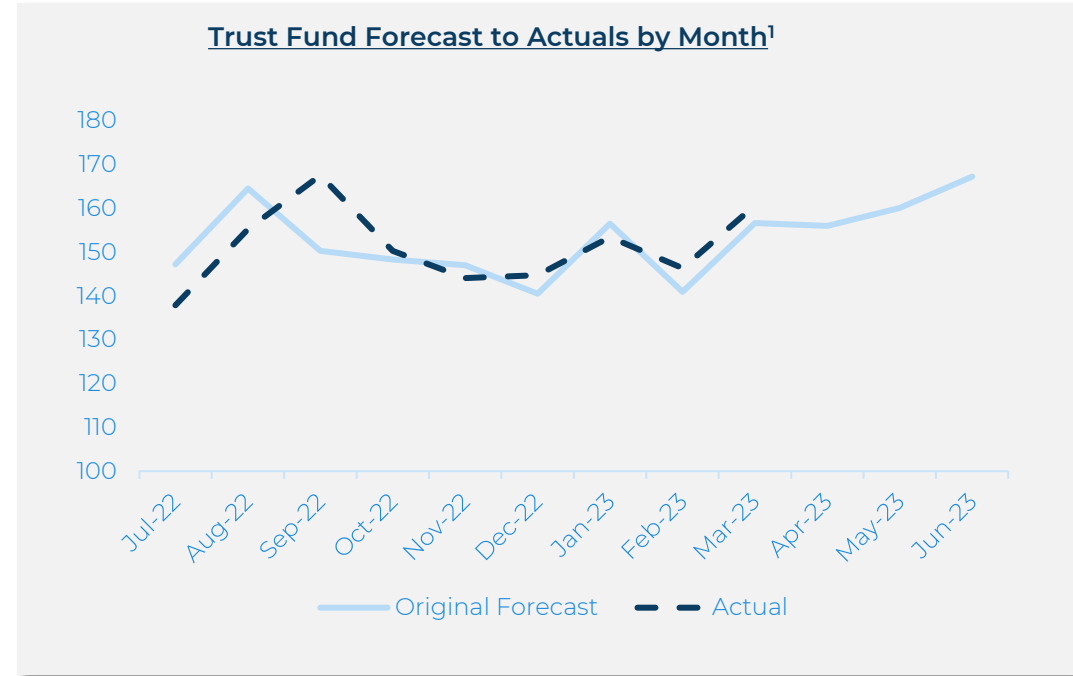
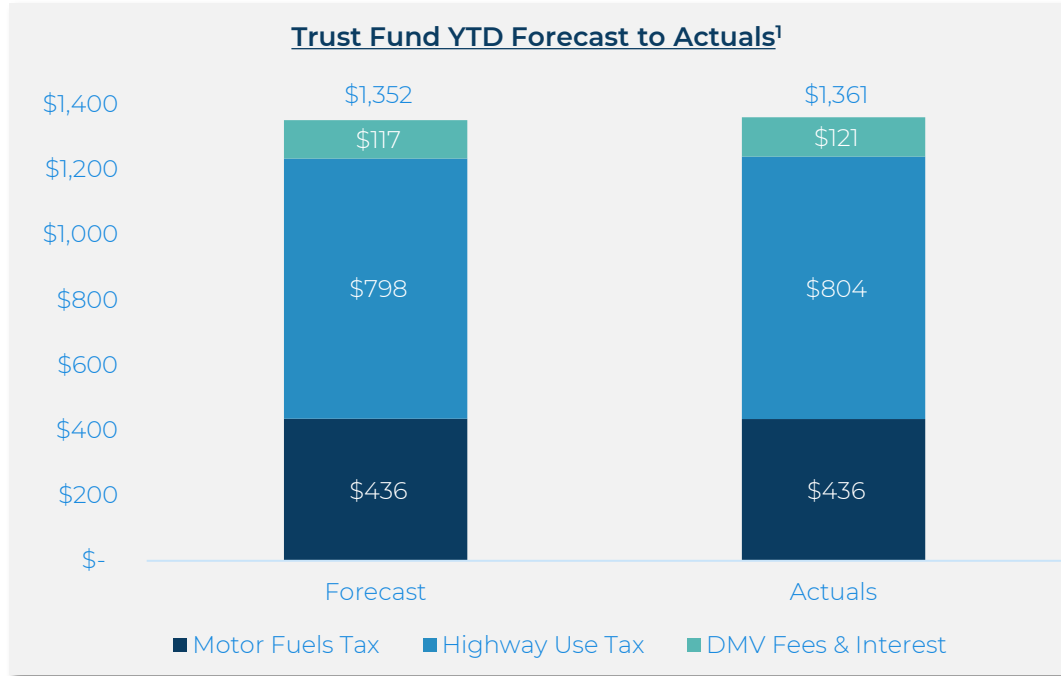

Trust Fund Revenue Commentary

- Total revenue of \$1,361m YTD which represents 30% of total NCDOT revenue and is currently 1.7% above forecast

1. \$ Millions, excludes federal revenues

Detail

Motor Fuel Tax Snapshot

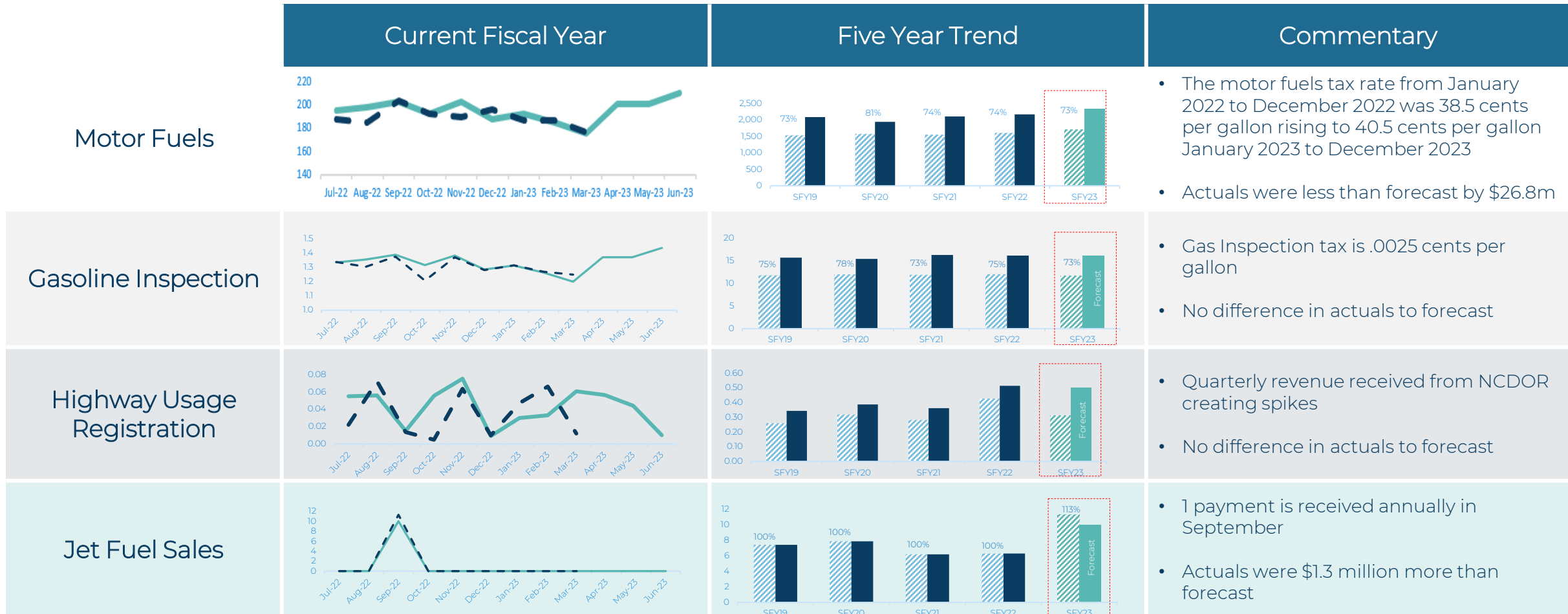

— Forecast — Actuals

▨ YTD - Actual

■ Total Annual - Actual

May 4, 2023

Highway Use Tax Snapshot

\$ millions

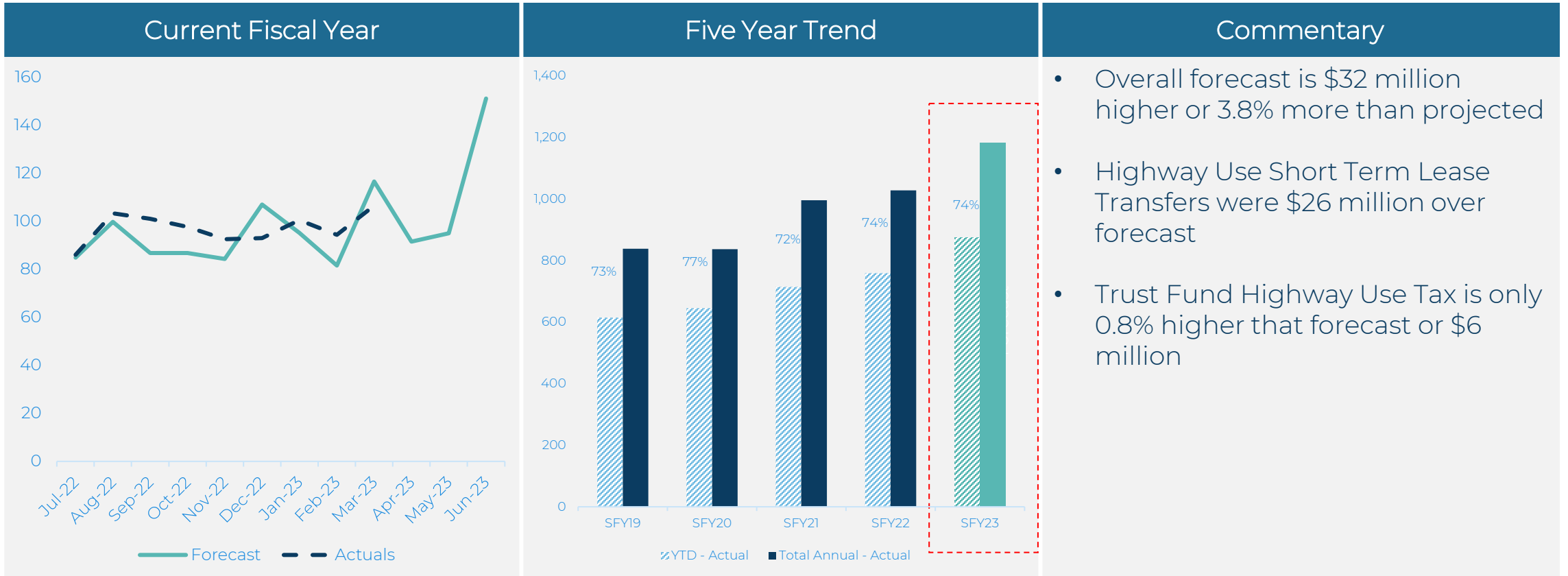

DMV Fees & Interest Snapshot

	Current Fiscal Year	Five Year Trend	Commentary
Staggered Registration			Year to date actuals received are \$9.6 million higher than forecast
Driver Licenses			Year to date actuals received are \$1.5 million higher than forecast
Truck Licenses			Year to date actuals received are \$6.5 million higher than forecast
International Registration Plan			No difference in year to date actuals received versus forecast
Other			Year to date actuals received are \$11.9 million higher than forecast

Sales Tax Snapshot

\$ millions

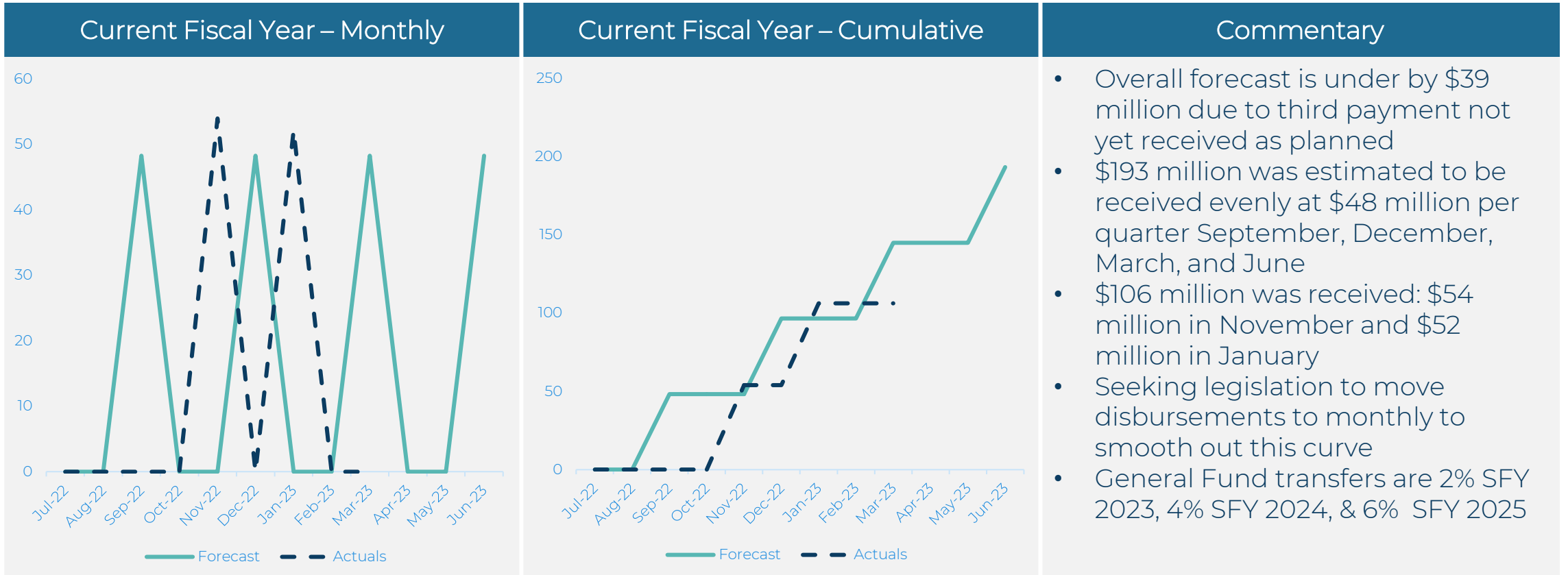

Federal Revenue Snapshot

\$ millions

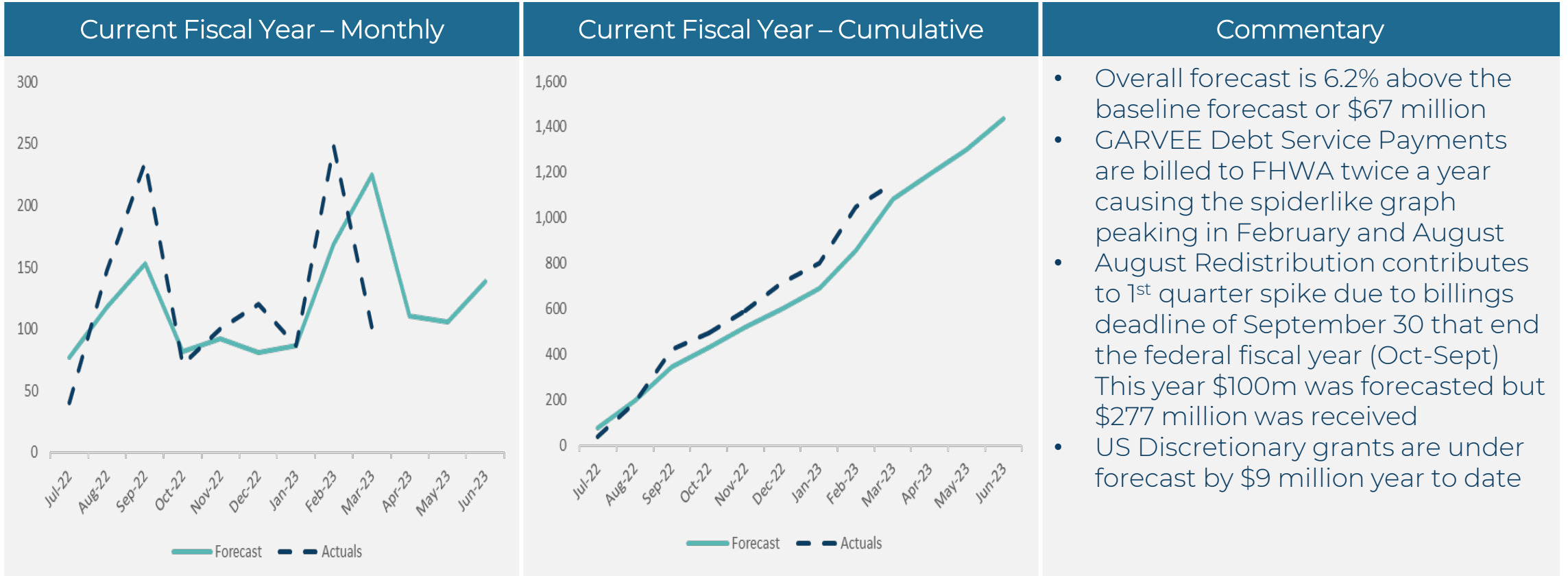

Macroeconomic Overview



Macroeconomic Overview

Quarterly Real GDP as Percent of Q4 2019¹

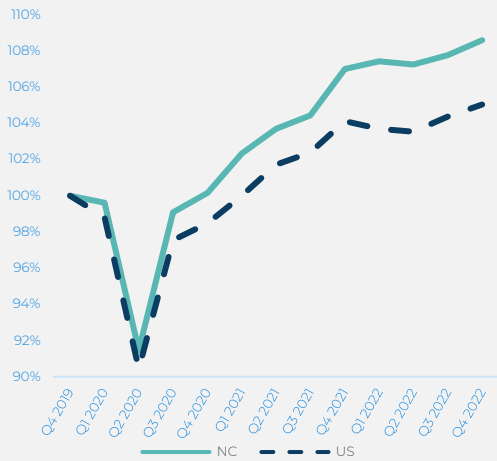

Unemployment Rate¹

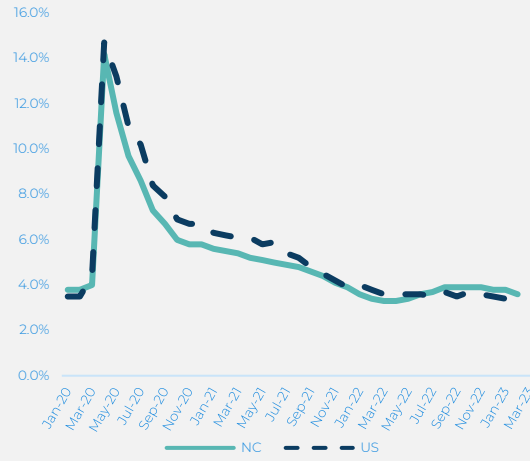

Labor Force Participation Rate¹

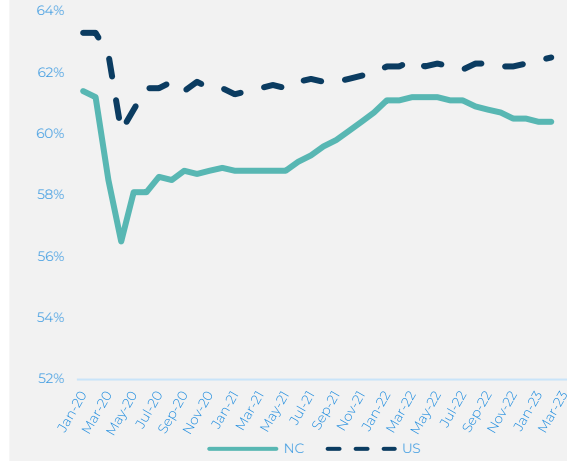

YoY Change in PPI¹ Construction Inputs and CPI²

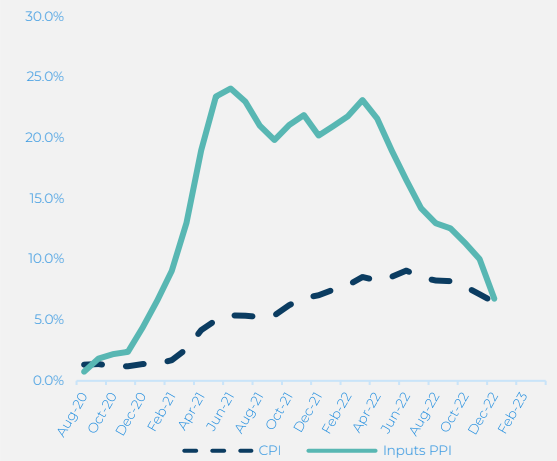

- Aggregate production of goods and services (GDP) continues to increase at an annual rate better than the national rate
- Increases are also greater than before COVID-19

- Unemployment Rate Dropped to 3.6% in February for NC compared to 3.8% prior to COVID-19
- However, Total statewide jobs are still less than pre-pandemic levels

- The % of available individuals who are of working age and either have jobs or are looking for jobs is smaller than before COVID-19
- Smaller labor force is one of the reasons behind labor shortages in transportation

- The producer price index (PPI) has exceeded the consumer price index for inflation every month since August 2020 until December 2022
- #2 Diesel fuel increased 61.5% from 10/21 to 9/22 & Asphalt increased 20.7%

1. Source: NCDOT Board of Transportation Meeting Minutes
 2. Source: www.bls.gov/cpi



NORTH CAROLINA

Department of Transportation



Disaster Funding

Emily McGraw, PE State Maintenance Engineer

May 3, 2023 – Finance Committee

Federal Agencies



U.S. Department of Transportation
**Federal Highway
Administration**

- Provides reimbursement for damages to Federal Aid routes, typically US, NC, and Interstate routes.
- ER funding is potentially available when an event causes at least \$700,000 (Federal share) in eligible damage during an event to the State's Federal Aid highway system
- \$5,000 current minimum project threshold
- Potential Eligible Work:
 - Emergency Repairs (100%)
 - Restore essential traffic
 - Minimize extent of damage
 - Protect the remaining facilities
 - Permanent Repairs
 - Interstate highways (90%)
 - All other Federal Aid routes (80%)





Federal Agencies

FEMA

- Provides potential reimbursement for damages to non-Federal Aid State maintained routes
- NC currently needs to exceed the ~\$18.5M Preliminary Damage Assessment threshold (based on “in-kind” repair or replacement) to receive a FEMA recommendation for a major disaster declaration. This Public Assistance (PA) allows for a Federal reimbursement of eligible costs at a percentage of 75 (at least) and a Local match of 25 percent
- \$3,800 current minimum project threshold
- Potential Eligible Work:
 - Cat A – Debris Removal
 - Cat B – Emergency Protective Measures
 - Cat C – Roads/Bridges
 - Cat E – Buildings/Equipment





Federally Declared Disaster Reimbursement Process

* Timelines are from when the event occurs.
 ** Timelines provided are indicative of larger storms such as Hurricanes Matthew and Florence. Influencing factors include size of the storm, type of damages accrued, and the number of ongoing events both in NC and nationally.

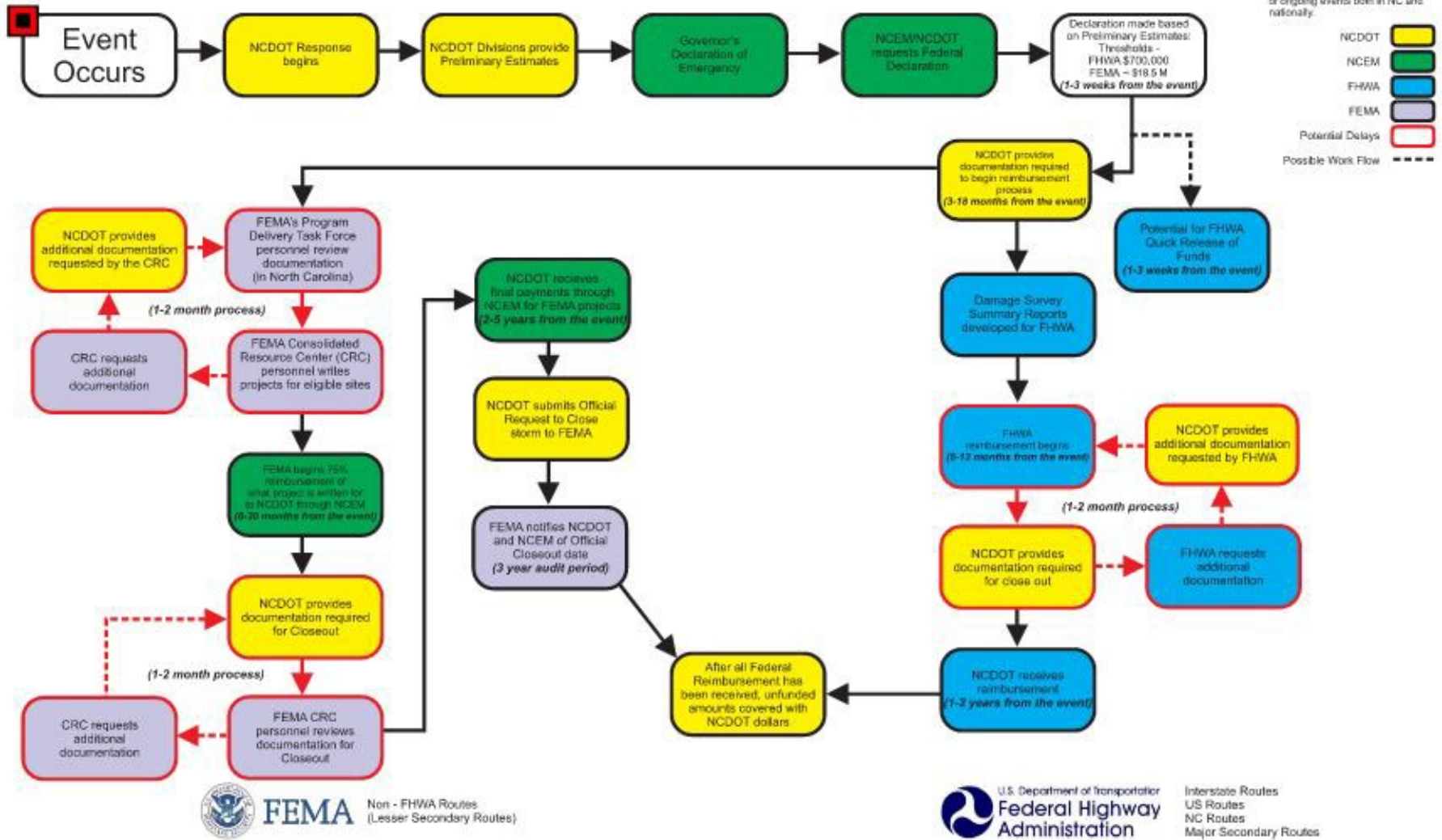

FHWA ER Reimbursement Status

Event	FHWA (Reimbursement Rate for Eligible Expenditures = 80%)						
	Total Expenditures to Date* ⁽¹⁾	Eligible Expenditures to Date ⁽²⁾	Eligible Expenditures Submitted for Reimbursement ⁽³⁾	Remaining Eligible Expenditures (Pending Processing) ⁽⁴⁾	Anticipated Reimbursement ⁽⁵⁾	Reimbursement Applied to Date*	Reimbursement Remaining to be Applied ⁽⁶⁾
2021 Nov 7 Coastal Flooding	\$ 6,098,111	\$ 5,804,759	\$ 5,804,759	\$ -	\$ 4,643,807	\$ (4,643,807)	\$ -
2021 Fred Severe Weather	\$ 7,345,560	\$ 4,750,000	\$ 3,680,096	\$ 1,069,904	\$ 3,800,000	\$ (2,944,077)	\$ 855,923
2020 TS Eta (Nov 11 Rains)	\$ 4,272,813	\$ 1,875,000	\$ 1,154,983	\$ 720,018	\$ 1,500,000	\$ (923,986)	\$ 576,014
2020 February 6 Rains	\$ 4,464,453	\$ 2,873,178	\$ 2,158,968	\$ 714,211	\$ 2,298,543	\$ (1,727,174)	\$ 571,369
2019 Hurricane Dorian	\$ 14,629,457	\$ 7,849,294	\$ 1,895,039	\$ 5,954,255	\$ 6,279,435	\$ (1,516,031)	\$ 4,763,404
2019 June Rains	\$ 2,067,656	\$ 2,221,763	\$ 1,453,343	\$ 768,420	\$ 1,777,410	\$ (1,162,674)	\$ 614,736
2019 February Rains	\$ 46,026,382	\$ 22,735,286	\$ 16,277,236	\$ 6,458,050	\$ 18,188,229	\$ (13,021,789)	\$ 5,166,440
2018 Hurricane Michael	\$ 3,791,506	\$ 2,721,509	\$ 3,423,953	\$ (702,444)	\$ 2,177,207	\$ (2,739,162)	\$ (561,955)
2018 Hurricane Florence	\$ 86,546,103	\$ 73,402,249	\$ 51,605,897	\$ 21,796,351	\$ 58,721,799	\$ (41,284,718)	\$ 17,437,081
2018 TS Alberto	\$ 10,634,474	\$ 10,055,996	\$ 10,055,996	\$ -	\$ 8,044,797	\$ (8,044,797)	\$ -
2016 Hurricane Matthew	\$ 59,847,318	\$ 59,290,809	\$ 59,290,809	\$ -	\$ 47,432,647	\$ (47,432,647)	\$ -
Total	\$ 245,723,832	\$ 193,579,842	\$ 156,801,078	\$ 36,778,765	\$ 154,863,874	\$ (125,440,862)	\$ 29,423,012

- ⁽¹⁾ NCDOT's storm related incurred costs to date; further expenditures will occur as DOT continues to repair damage
- ⁽²⁾ NCDOT's evaluation of *Total Expenditures to Date* to determine potential eligible reimbursable costs based on declarations and emergency relief guidelines
- ⁽³⁾ Total amount of eligible expenses with supporting documentation submitted to either FHWA or FEMA for authorization
- ⁽⁴⁾ Difference between *Eligible Expenditures to Date* and *Eligible Expenditures Submitted for Reimbursement*
- ⁽⁵⁾ Standard reimbursement percentage of *Eligible Expenditures to Date* from FHWA or FEMA
- ⁽⁶⁾ Difference between *Anticipated Reimbursement* and *Reimbursement Applied/Received to Date*

FEMA PA Reimbursement Status

Event	FEMA (Reimbursement Rate for Eligible Expenditures = 75%, ** = 90%)						
	Total Expenditures to Date* ⁽¹⁾	Eligible Expenditures to Date ⁽²⁾	Eligible Expenditures Submitted for Reimbursement ⁽³⁾	Remaining Eligible Expenditures (Pending Processing) ⁽⁴⁾	Anticipated Reimbursement ⁽⁵⁾	Reimbursement Received to Date*	Reimbursement Remaining to be Received ⁽⁶⁾
2022 TS Ian	\$ 10,176	\$ 10,176	\$ 10,176	\$ -	\$ 7,632	\$ -	\$ 7,632
** 2021 Fred Severe Weather	\$ 20,594,648	\$ 16,820,523	\$ 13,268,873	\$ 3,551,650	\$ 15,138,471	\$ (8,000,495)	\$ 7,137,976
** 2020 TS Eta (Nov 11 Rains)	\$ 34,484,109	\$ 28,601,759	\$ 28,601,759	\$ -	\$ 25,741,583	\$ (16,368,104)	\$ 9,373,479
** 2020 TS Isaias	\$ 4,914,328	\$ 3,085,724	\$ 3,071,008.92	\$ -	\$ 2,763,908	\$ (2,251,620)	\$ 512,288
2020 COVID-19	\$ 1,300,532	\$ 158,531	\$ 129,864.28	\$ -	\$ 129,864	\$ (129,864)	\$ -
** 2020 February 6 Rains	\$ 18,251,372	\$ 12,990,078	\$ 12,698,818.52	\$ -	\$ 11,428,937	\$ (6,085,683)	\$ 5,343,253
2019 Hurricane Dorian	\$ 15,480,515	\$ 6,073,953	\$ 5,715,244.17	\$ -	\$ 4,286,433	\$ (3,302,929)	\$ 983,504
2018 Hurricane Michael	\$ 13,680,074	\$ 8,593,918	\$ 8,111,712.99	\$ -	\$ 6,083,785	\$ (6,364,240)	\$ (280,455)
2018 Hurricane Florence	\$ 161,299,046	\$ 159,006,019	\$ 148,443,065.77	\$ -	\$ 111,332,299	\$ (107,589,932)	\$ 3,742,368
2016 Hurricane Matthew	\$ 143,372,000	\$ 138,457,794	\$ 138,117,934.85	\$ -	\$ 103,588,451	\$ (74,599,022)	\$ 28,989,429
Total	\$ 413,386,801	\$ 373,798,474	\$ 358,168,458	\$ 3,551,650	\$ 280,501,364	\$ (224,691,890)	\$ 55,809,474

- ⁽¹⁾ NCDOT's storm related incurred costs to date; further expenditures will occur as DOT continues to repair damage
- ⁽²⁾ NCDOT's evaluation of *Total Expenditures to Date* to determine potential eligible reimbursable costs based on declarations and emergency relief guidelines
- ⁽³⁾ Total amount of eligible expenses with supporting documentation submitted to either FHWA or FEMA for authorization
- ⁽⁴⁾ Difference between *Eligible Expenditures to Date* and *Eligible Expenditures Submitted for Reimbursement*
- ⁽⁵⁾ Standard reimbursement percentage of *Eligible Expenditures to Date* from FHWA or FEMA
- ⁽⁶⁾ Difference between *Anticipated Reimbursement* and *Reimbursement Applied/Received to Date*

FHWA/FEMA Reimbursement Totals

Event	FHWA and FEMA Reimbursement Totals						
	Total Expenditures to Date* ⁽¹⁾	Eligible Expenditures to Date ⁽²⁾	Eligible Expenditures Submitted for Reimbursement ⁽³⁾	Remaining Eligible Expenditures (Pending Processing) ⁽⁴⁾	Anticipated Reimbursement ⁽⁵⁾	Reimbursement Applied/Received to Date*	Reimbursement Remaining to be Applied/Received ⁽⁶⁾
2021 TS Ian	\$ 10,176	\$ 10,176	\$ 10,176	\$ -	\$ 7,632	\$ -	\$ 7,632
2021 Nov 7 Coastal Flooding	\$ 6,098,111	\$ 5,804,759	\$ 5,804,759	\$ -	\$ 4,643,807	\$ (4,643,807)	\$ -
2021 Fred Severe Weather	\$ 27,940,207	\$ 21,570,523	\$ 16,948,970	\$ 4,621,554	\$ 18,938,471	\$ (10,944,572)	\$ 7,993,899
2020 TS Eta (Nov 11 Rains)	\$ 38,756,922	\$ 30,476,759	\$ 29,756,742	\$ 720,018	\$ 27,241,583	\$ (17,292,090)	\$ 9,949,493
2020 TS Isaias	\$ 4,914,328	\$ 3,085,724	\$ 3,071,009	\$ -	\$ 2,763,908	\$ (2,251,620)	\$ 512,288
2020 COVID-19	\$ 1,300,532	\$ 158,531	\$ 129,864	\$ -	\$ 129,864	\$ (129,864)	\$ -
2020 February 6 Rains	\$ 22,715,825	\$ 15,863,256	\$ 14,857,786	\$ 714,211	\$ 13,727,479	\$ (7,812,857)	\$ 5,914,622
2019 Hurricane Dorian	\$ 30,109,972	\$ 13,923,247	\$ 7,610,283	\$ 5,954,255	\$ 10,565,868	\$ (4,818,960)	\$ 5,746,908
2019 June Rains	\$ 2,067,656	\$ 2,221,763	\$ 1,453,343	\$ 768,420	\$ 1,777,410	\$ (1,162,674)	\$ 614,736
2019 February Rains	\$ 46,026,382	\$ 22,735,286	\$ 16,277,236	\$ 6,458,050	\$ 18,188,229	\$ (13,021,789)	\$ 5,166,440
2018 Hurricane Michael	\$ 17,471,580	\$ 11,315,427	\$ 11,535,665	\$ (702,444)	\$ 8,260,992	\$ (9,103,402)	\$ (842,410)
2018 Hurricane Florence	\$ 247,845,150	\$ 232,408,268	\$ 200,048,963	\$ 21,796,351	\$ 170,054,098	\$ (148,874,650)	\$ 21,179,449
2018 TS Alberto	\$ 10,634,474	\$ 10,055,996	\$ 10,055,996	\$ -	\$ 8,044,797	\$ (8,044,797)	\$ -
2016 Hurricane Matthew	\$ 203,219,317	\$ 197,748,603	\$ 197,408,744	\$ -	\$ 151,021,098	\$ (122,031,669)	\$ 28,989,429
Total	\$ 659,110,633	\$ 567,378,317	\$ 514,969,536	\$ 40,330,414	\$ 435,365,237	\$ (350,132,752)	\$ 85,232,486

⁽¹⁾ NCDOT's storm related incurred costs to date; further expenditures will occur as DOT continues to repair damage

⁽²⁾ NCDOT's evaluation of *Total Expenditures to Date* to determine potential eligible reimbursable costs based on declarations and emergency relief guidelines

⁽³⁾ Total amount of eligible expenses with supporting documentation submitted to either FHWA or FEMA for authorization

⁽⁴⁾ Difference between *Eligible Expenditures to Date* and *Eligible Expenditures Submitted for Reimbursement*

⁽⁵⁾ Standard reimbursement percentage of *Eligible Expenditures to Date* from FHWA or FEMA

⁽⁶⁾ Difference between *Anticipated Reimbursement* and *Reimbursement Applied/Received to Date*

Questions?





PRODUCT INNOVATION – Vanguard EcoPath Coating

Vanguard EcoPath Coating by Vanguard ADA Systems is a liquid applied monomer used as pavement markings for depicting bicycle, pedestrian, and bus traffic lanes. EcoPath is available in red and green, can contain slip resistant additives, such as sand, as well as glass beads for reflectivity, and can be applied to multiple surfaces including concrete and asphalt. It is also durable and can last up to 9 times longer than paint. The finish is ready for traffic in as little as 90 minutes. EcoPath is manufactured in Snohomish, Washington and is currently under evaluation on the APL as NP23-9214. For more information, please visit: <https://vanguardonline.com/ecopath/>



Image of Vanguard EcoPath Coating being applied (Left) and a completed bicycle path marking (Right).
 Images from Vanguard’s website.

PRODUCT HIGHLIGHT – StripeMaster® 2 Touch Retroreflectometer



Image of the StripeMaster® 2 Touch Retroreflectometer from RoadVista’s product brochure.

The StripeMaster® 2 Touch Retroreflectometer is manufactured by Gamma Scientific and marketed by RoadVista out of San Diego, CA. It is Approved on the APL as NP22-9178. Retroreflectometers measure retroreflectivity of in place pavement markings. The Stripemaster® 2 Touch Retroreflectometer is a battery powered handheld model that is equipped with GPS and Bluetooth for locating and storing up to 25,000 data points. It also contains a top-mounted touch screen, removable flash drive for data export, and lockable rotating handle designed to operate away from traffic. This device can accurately measure all industry standard colors.

For more information, please visit:
<https://www.roadvista.com/products/stripemaster-2-touch-retroreflectometer>.



NORTH CAROLINA
Department of Transportation

SPOT May BOT Update

Strategic Prioritization Office of Transportation (SPOT)

May 3, 2023

Today's Topics

- Workgroup Update
- Modal Allocation
- Review of Consensus Points
- Next Steps
- Questions & Open Discussion



Workgroup Update

Workgroup Update

Recent and Upcoming Activities

Recent Activities:

- In-Person Meeting: April 11
- Virtual Meeting: April 20

Upcoming Activities:

- In-Person Meeting: May 9



Workgroup Update

Recent Consensus Points Update

#	Decision Point / Topic	Consensus Date	Description of Consensus Decision / Notes	Prioritization Process Category
15	Resiliency – Statewide Model Segment Analysis	1/24/23	Do not pursue for P7	Scoring - Highway
16	Socio-Economic Analysis – IMD Equity and Transportation	1/24/23	Incorporate TDI into SPOT Online for testing; implementation TBD	Scoring - All
17	Socio-Economic Analysis – Socio-Economic Geospatial Analysis	1/24/23	Add new data sets	Scoring - All
18	Highway Criteria – Accessibility/Connectivity	1/24/23	Coordinate with Planning	Scoring - Highway
19	Highway Criteria – Multimodal	1/24/23	Coordinate with Planning	Scoring - Highway
20	Carryover Definition	1/24/23	Continue using P6 definition	Projects to Score
21	Number of Submittals	1/24/23	Continue using P6 formula	Projects to Score
22	Number of Local Input Points	1/24/23	Continue using P6 formula	Local Input Points
23	TDI Implementation	2/14/23	Use only for testing in Highway and BikePed	Scoring - All
24	Carryover of P6 Submittals	2/14/23	Two P6 submittals to be included with Carryovers	Projects to Score
25	Ferry Scoring	2/14/23	Use P6 Methodology with updated SITs	Scoring - Ferry
26	Aviation Scoring	2/14/23	Use P6 Methodology with updated SITs	Scoring - Aviation
27	Economic Competitiveness Models	2/14/23	Continue TREDIS; explore the use of other outputs	Scoring - Highway
28	Bike/Ped Points of Interest	3/14/23	Do not pursue relative Points of Interest	Scoring - Bike/Ped
29	Bike/Ped Points of Interest	3/14/23	Continue with manual employment data entry	Scoring - Bike/Ped
30	TDI Implementation	3/14/23	Use a two-mile buffer for Highway projects	Scoring - Highway
31	Bike/Ped Scoring	3/14/23	Use P6 Methodology with POI adjustments	Scoring - Bike/Ped
32	Normalization / Modal Allocation	4/11/23	Use P6 Methodology	Funding
33	LIP Donations	4/11/23	Use P6 Methodology	Local Input Points
34	LIP Flexing	4/11/23	Use P6 Methodology	Local Input Points
35	Submittal Donations	4/11/23	Use P6 Methodology	Projects to Score
36	Area-Specific Weights	4/11/23	Use P6 Methodology	Scoring - All
37	Transit Scoring	4/11/23	Use P6 Methodology with minor Revisions	Scoring - Transit
38	Rail Modernization Scoring	4/11/23	Used methodology Developed by Rail	Scoring - Rail
39	Rail Scoring	4/11/23	Use P6 Methodology	Scoring - Rail
40	Highway Scoring	Underway	Continue discussion on 5/9	Scoring - Highway

P7 Prioritization Process

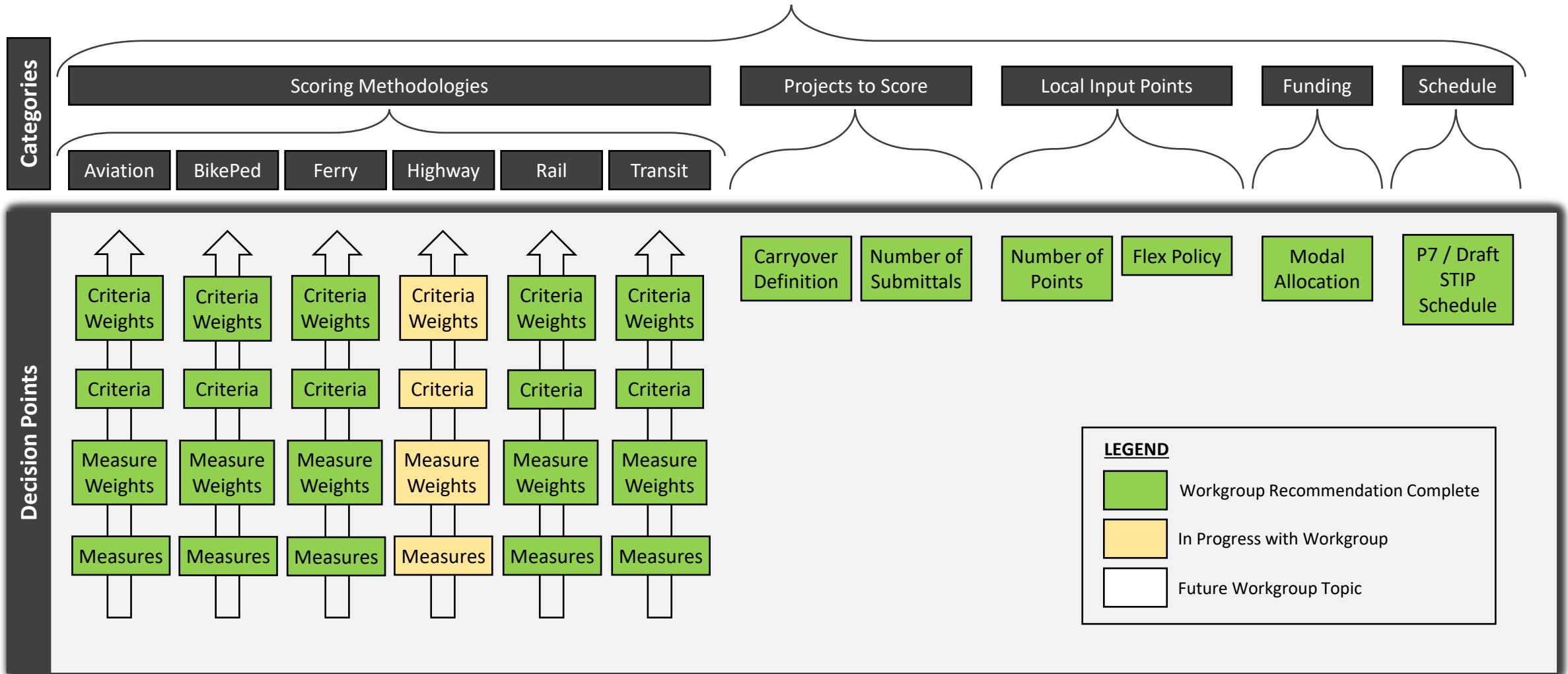

Recommendations are developed by the Prioritization Workgroup and presented to the Board of Transportation for approval.

April 17, 2023

Modal Allocation

Modal Allocation

Background and Current Process

- Challenge: Intent of STI legislation is to fund best transportation projects, regardless of mode; but different criteria and weights are used in each mode
- **Modal Allocation** = Split of funds between Highway & Non-Highway Projects

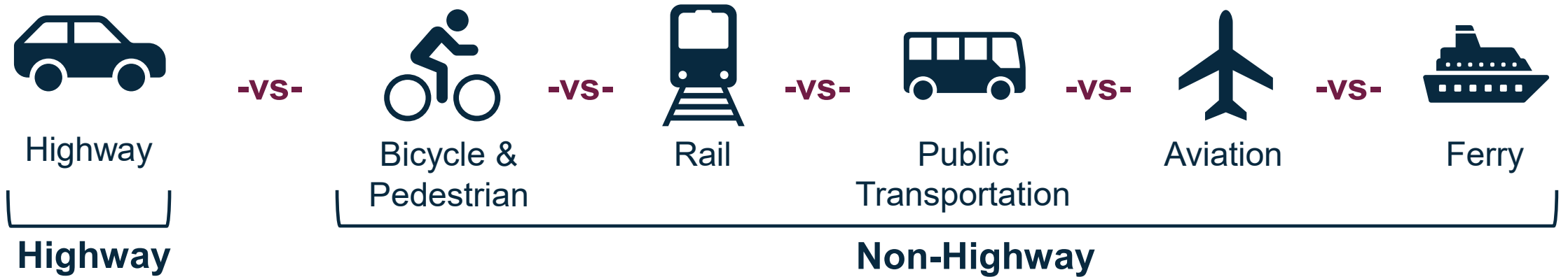

Regional Impact & Division Needs*

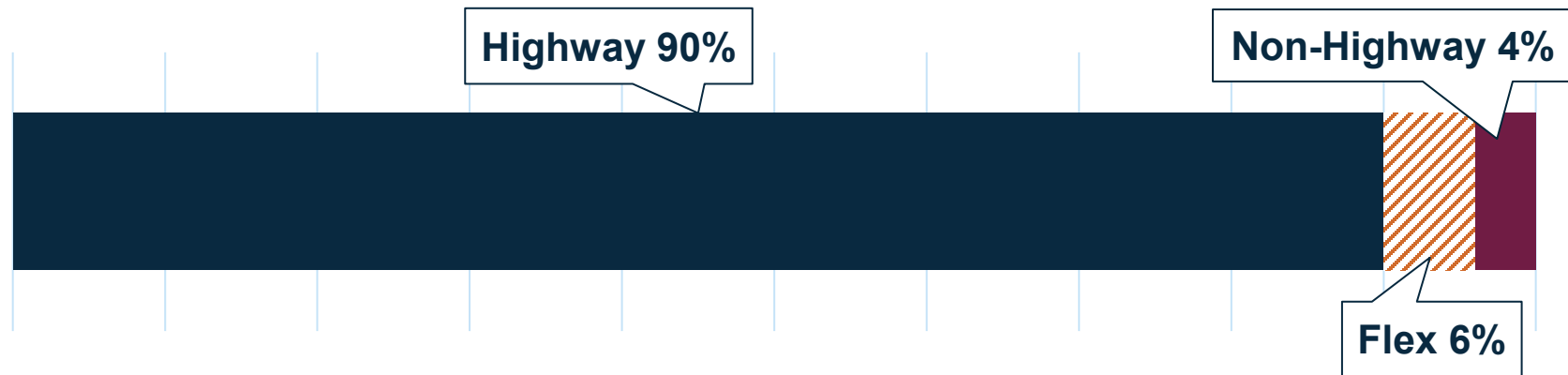

Workgroup Update

Modal Allocation

	Highway Minimum	Non-Highway Minimum	Flex
Current	90%	4%	6%*
Proposed	90%	6%	4%*

- The Workgroup is recommending:
 - Maintaining the 90% minimum for Highway
 - Adjusting the Non-Highway minimum from 4% to 6%
 - Adjusting the Flex from 6% to 4%

Workgroup Update

Modal Allocation

	Highway Minimum	Non-Highway Minimum	Flex
Current	90%	4%	Max 6%
Proposed	90%	6%	Max 4%

- The Workgroup is recommending:
 - Maintaining the 90% minimum for Highway
 - Adjusting the Non-Highway minimum from 4% to 6%
 - Adjusting the Flex from 6% to 4%

Review of Consensus Points

Recommended P7 Schedule

- Fixed Dates
- Partner Input

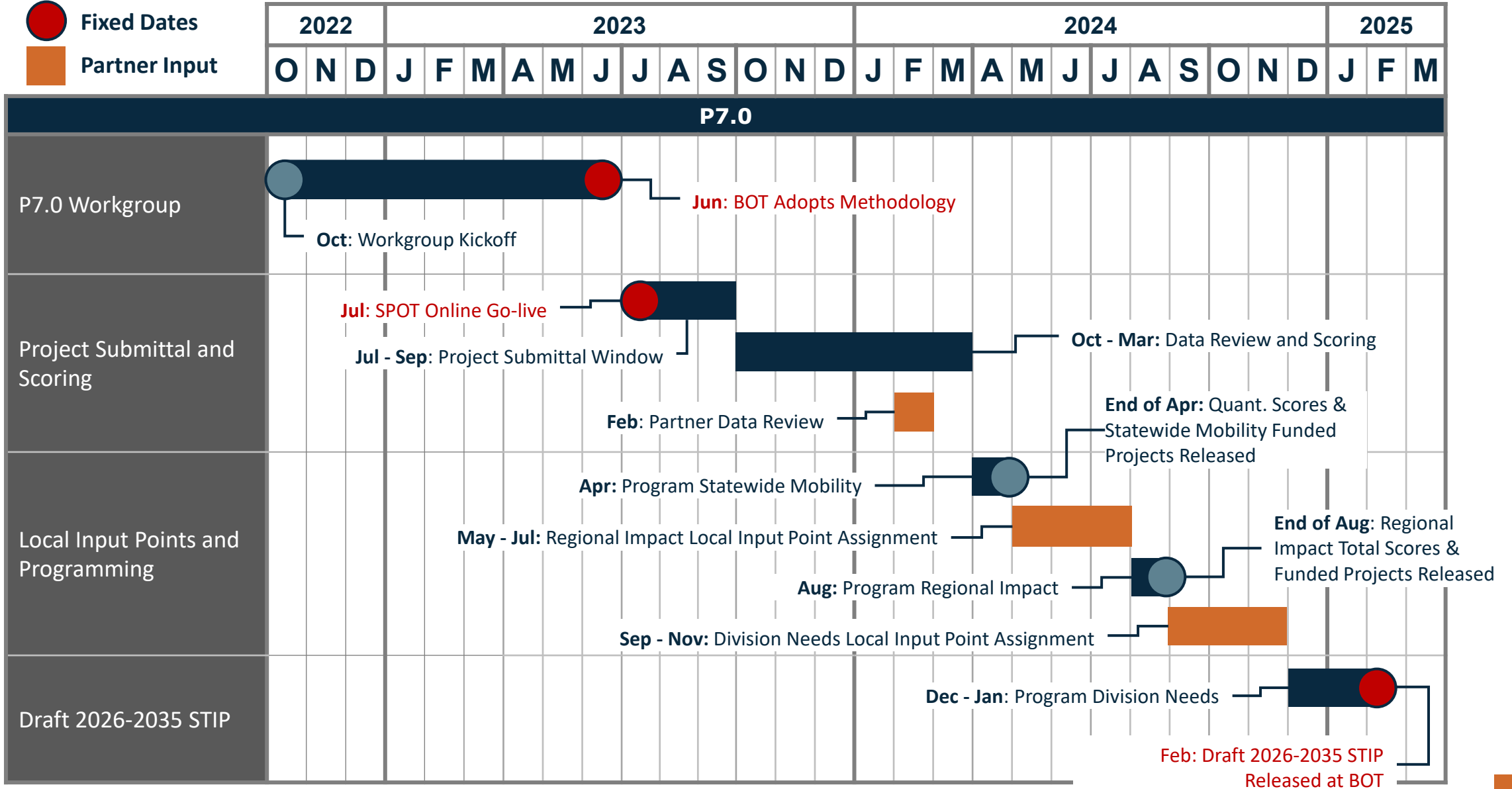

Review of Consensus Points

Carryovers, Submittals, and Local Input Points

- Carryover projects to be defined as:
 - In the adopted 2024 -2033 STIP and not scheduled for delivery
 - Have completed environmental documents
 - Sibling of programmed projects
 - Two New Projects from P6.0 (per partner discretion)
- The number of project submittals be calculated using the same formula as in P6
- The number of local input points be calculated using the same formula as in P6

Review of Consensus Points

Summary of Scoring Changes by Mode

Mode	Changes for P7
Aviation	Updates SITs to better align with projects
Bike/Ped	Use P6 scoring with approved adjustments to Points of Interest
Ferry	Updates to SITs and Ferry Routes
Public Transportation	Clarified that MicroTransit is included in Demand Response and confirmed that mobility hubs are eligible facilities
Rail	Addition of a new Rail Modernization SIT
Highway	TBD

- Changes for P7 have been relatively minor
- Many were focused on revisions to Specific Improvement Types (SITs) or clarifications of eligibility

Next Steps

Next Steps

- Highway Scoring
 - Finalizing in May 2023
- Board of Transportation Approval
 - Anticipated in June 2023
- Project Submittal Window*
 - July through September 2023
- Project Scoring*
 - October 2023 through March 2024



Questions & Open Discussion

Strategic Prioritization Office of Transportation (SPOT)

SPOT@ncdot.gov



NORTH CAROLINA
Department of Transportation

Highway Maintenance Improvement Program (HMIP)

Kristin Barnes, PE
Director of Highway Operations

Board of Transportation – May 2023

Summary of HMIP Legislation

- **Session Law 2014 -100, Section 34.11 (a,b):** the North Carolina General Assembly established the Highway Maintenance Improvement Program (HMIP)
- **Session Law 2017 -57:** to support the need for a more holistic approach to maintenance, the Highway (Pavements), Bridge and Routine Maintenance Improvement Programs were merged and are now managed under a single “Highway Maintenance Improvement Program”, effective January 1, 2020
- Program mandated in **G.S. 136-44.3A**
- 5-year schedule for highway pavement, bridge and routine maintenance activities.
- Based on the previous FY funding allocations

HMIP - Pavements

- **Method:** Pavement Condition Survey used to generate recommendations; Division staff review and update
- **Included Information:**
 - Planned fiscal year for work to be completed
 - Specific roadways/roadway sections in each county
 - Type of improvement and estimated cost

Plan Year	County	Route	Begin Description	End Description	Length	Budget Group	Treatment	Estimated Cost
FY 2024	Buncombe	SR 1374	SR 1369	NC 63	1.35	Resurfacing	1.5" S9.5A	\$ 216,000
FY 2024	Hyde	SR 1305	SR 1364	NC 94	6.16	Preservation	Seal - Double	\$ 235,000
FY 2025	Surry	SR 2049	SR 1857	EOM	1.23	Preservation	.75" S4.75A	\$65,000

HMIP - Bridges

- **Method:** Bridge inspection reports and field data used to generate recommendations; Division staff review and update
- **Included Information:**
 - Planned fiscal year for work to be completed
 - Structure location in each county
 - Estimated cost

DIV	Plan Year	County	Project ID	Improvement Type	Structure	Facility Carried	Intersected Feature	PE Estimate	Construction Estimate	Estimated Cost	Budget Group
1	2024	DARE	15BPR.46	Rehabilitation	270012	US64	ROANOKE SOUND	\$1,080,000	\$ 10,800,000	\$ 11,880,000	BPR
11	2025	CALDWELL	BP11-R001	Replacement	130029	NC268	YADKIN RIVER	\$196,500	\$1,965,000	\$ 2,161,500	HFBD
3	2024	BRUNSWICK	BP3-R004	Replacement	090181	SR1437	STURGEON CREEK	\$ 92,000	\$ 826,000	\$ 918,000	HFBD

HMIP - Routine

- **Method:** Division staff review asset inventories, recommended cycles, historic expenditures to create plans
- **Included Information:**
 - Planned fiscal year for work to be completed
 - Work Task, planned on Division level
 - Estimated cost
- **Example Tasks :** Mowing, Brush and Tree Control, Rest Areas, Litter Removal, Traffic Signal Routine Maintenance

Div	Plan Year	Plan Level	Function	Description	Budget Group	Plan Work	UOM	Estimated Cost
1	2024	RMIP	2900C	Grass Mowing	Roadside	54,252.79	SHM	\$4,068,959.10
4	2024	RMIP	2908	Brush and Tree Control /Herbicides	GMR	336.41	SHM	\$365,007.00

HMIP Timeline

Date	Action
1 st week of May 2023	Members of the Board - receive a brief overview of HMIP Members of the Board and division engineers - receive HMIP files
Month of May 2023	Members of the Board - meet with respective division engineer to review
June 8, 2023	Members of the board - vote to approve the HMIP
Upon Board approval	The final, approved HMIP available on the NCDOT website

Thank you!



NORTH CAROLINA
Department of Transportation



NC DMV Recruitment & Staffing Update

Amanda Olive

April 2023

Connecting people, products and places safely and efficiently with customer focus, accountability and environmental sensitivity to enhance the economy and vitality of North Carolina

NCDOT & NCDMV Staffing - Vacancies

NCDOT Vacancies have grown over the past 4 years. (+437)

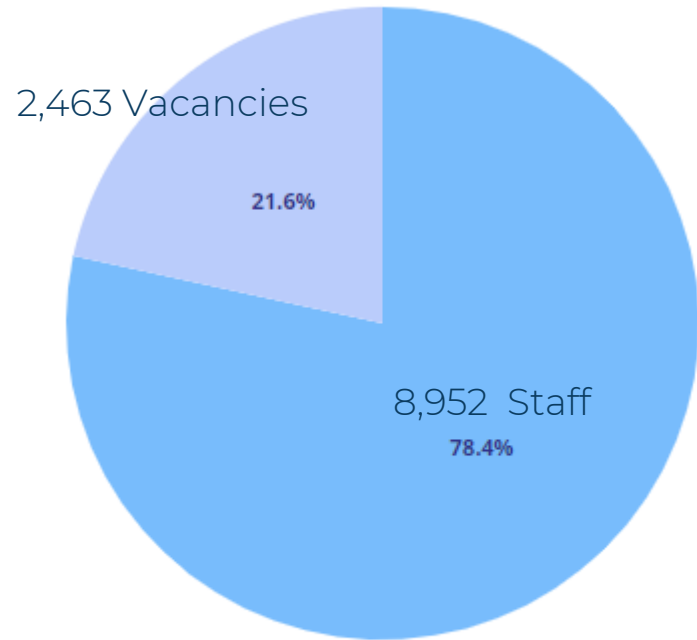

■ Filled Positions ■ Vacant Positions

Apr 2023
11,415 Positions

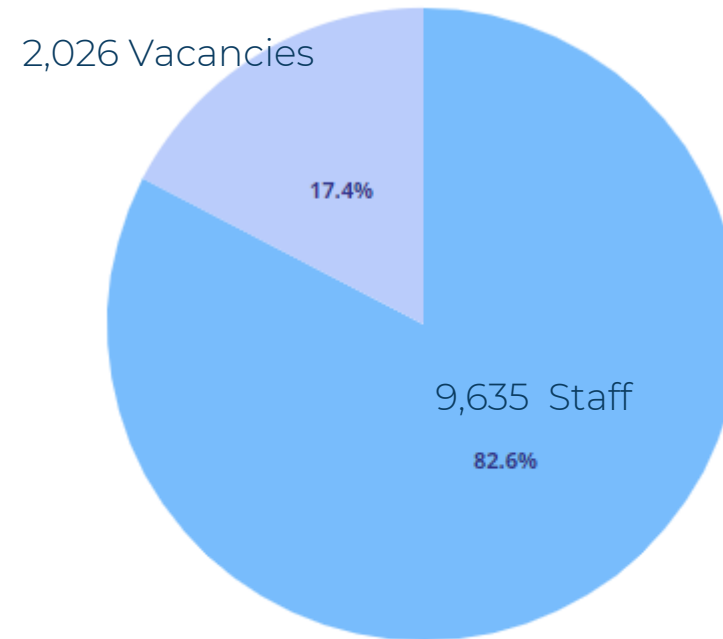

■ Filled Positions ■ Vacant Positions

Apr 2019
11,661 Positions

NCDMV Vacancies have grown over the past 4 years. (+94)

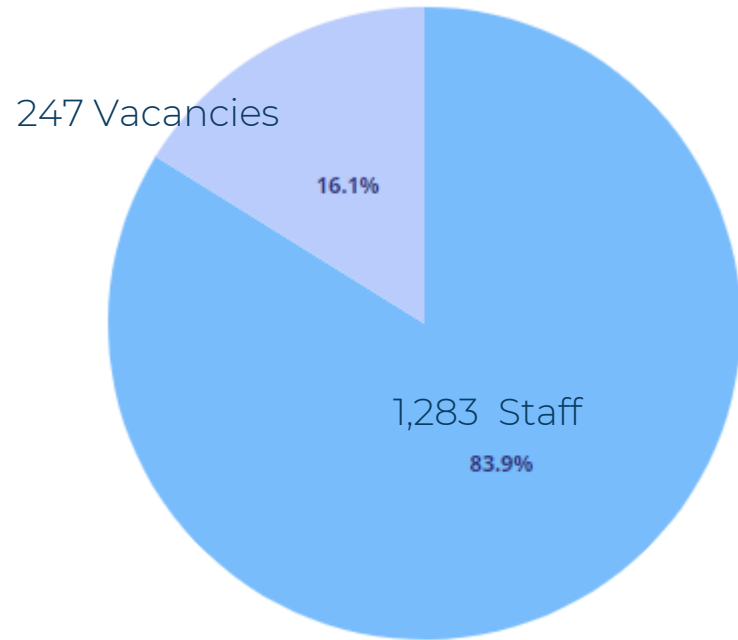

■ Filled Positions ■ Vacant Positions

Apr 2023

1,530 Positions

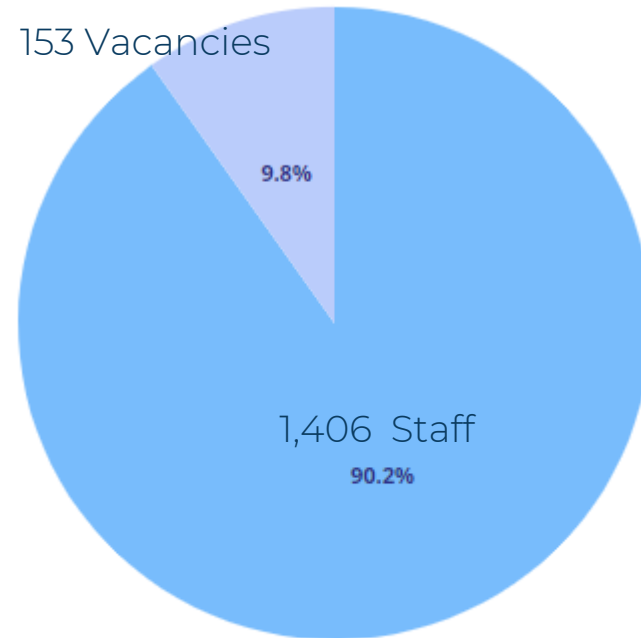

■ Filled Positions ■ Vacant Positions

Apr 2019

1,559 Positions

Program Management, Administrative Support, & Law Enforcement are NCDMV's 3 Largest Areas with Vacancies.

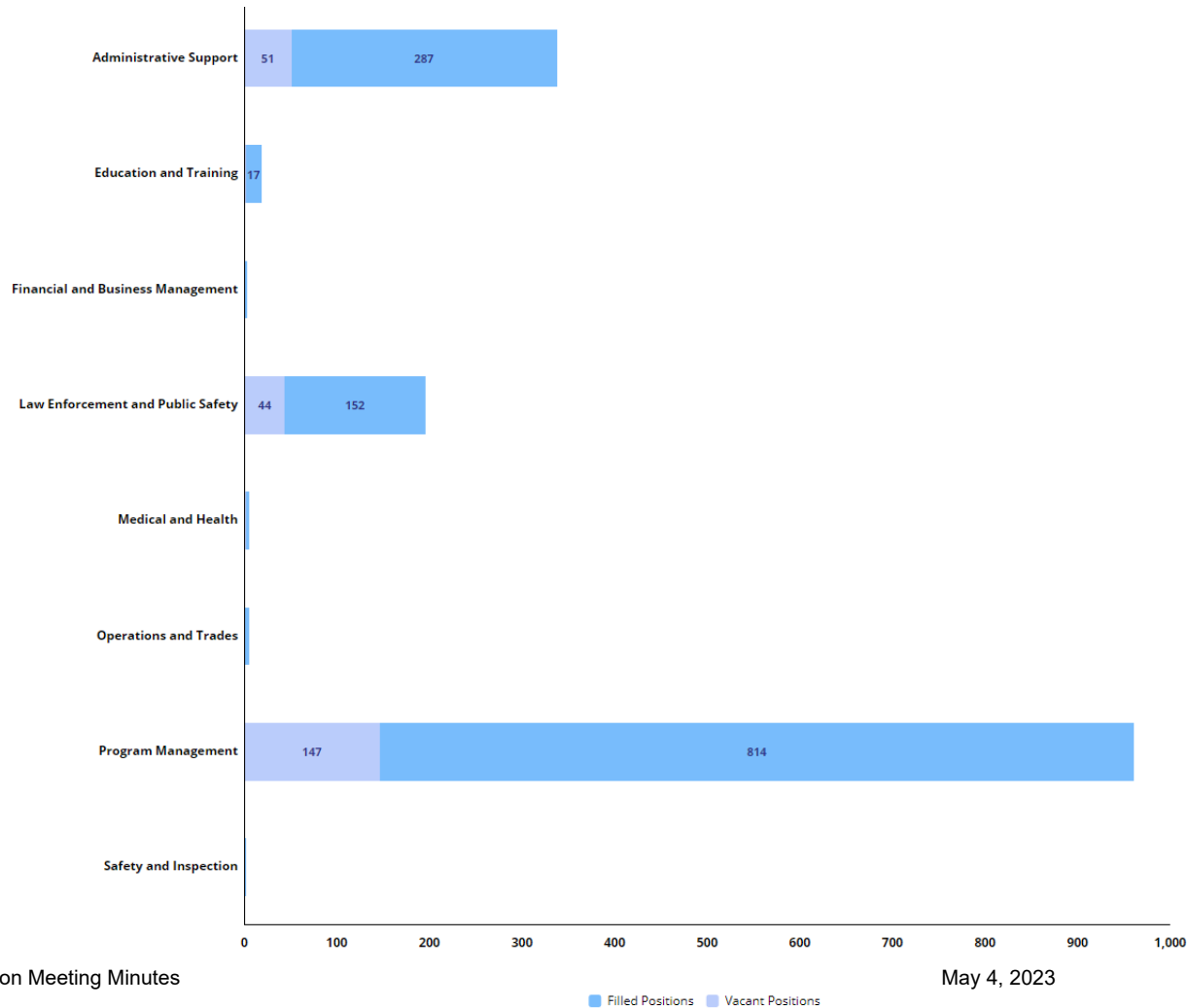

Apr 2023 NCDMV Vacancy Rate by County

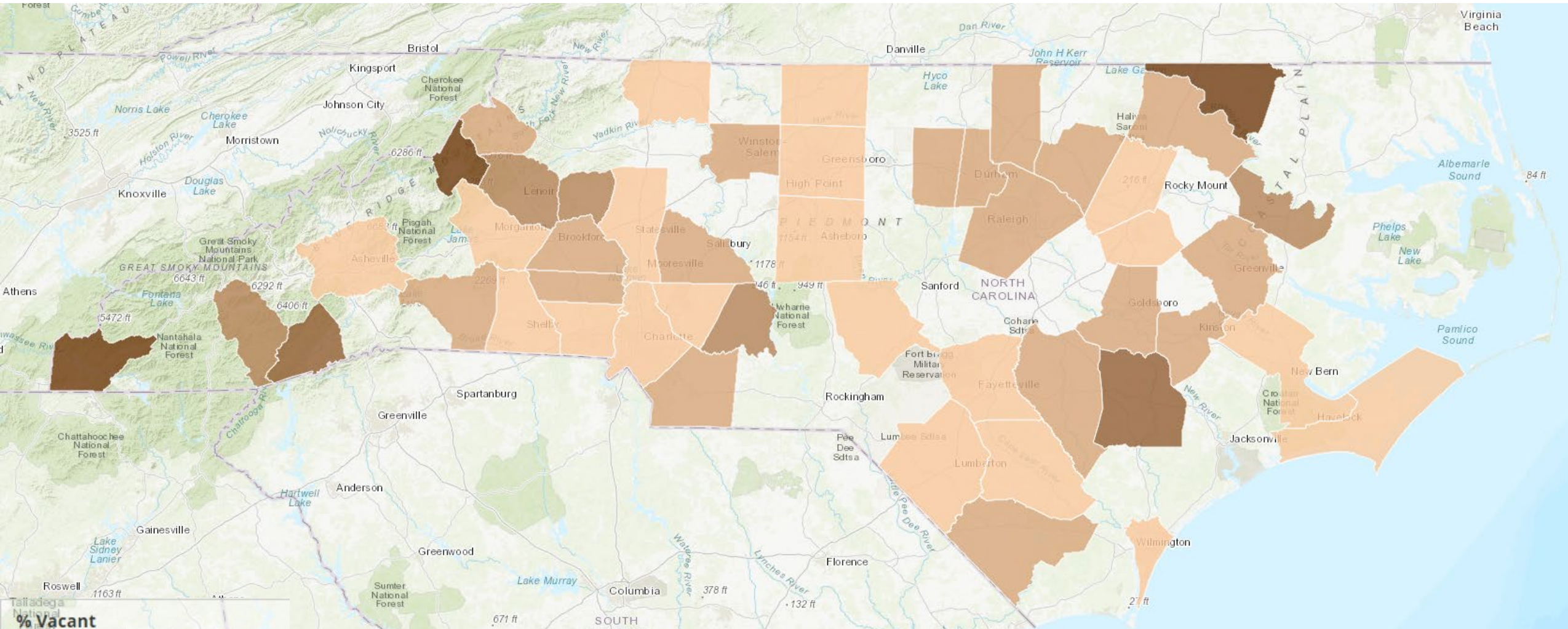

% Vacant
NCDOT Board of Transportation Meeting Minutes

May 4, 2023

Source: Beacon report B0194: Positions Vacant-Filled

NCDMV Staffing - Turnover

NCDMV Turnover by Reason 2023 versus 2019 shows separations decreased (-20) from 2019.

NCDMV Turnover 5/22 – 4/23

Voluntary Separation	109	(+9)
Retirement	30	(-26)
Internal Transfers	76	(-13)
External Transfers	20	(-1)
Involuntary Separation	19	(+11)
Total Separations	254	(-20)

NCDMV Turnover 5/18 – 4/19

Voluntary Separation	100
Retirement	56
Internal Transfers	89
External Transfers	21
Involuntary Separation	8
Total Separations	274

NCDMV Separations by Job Family 2023 Versus 2019

NCDOT Turnover 5/22 – 4/23

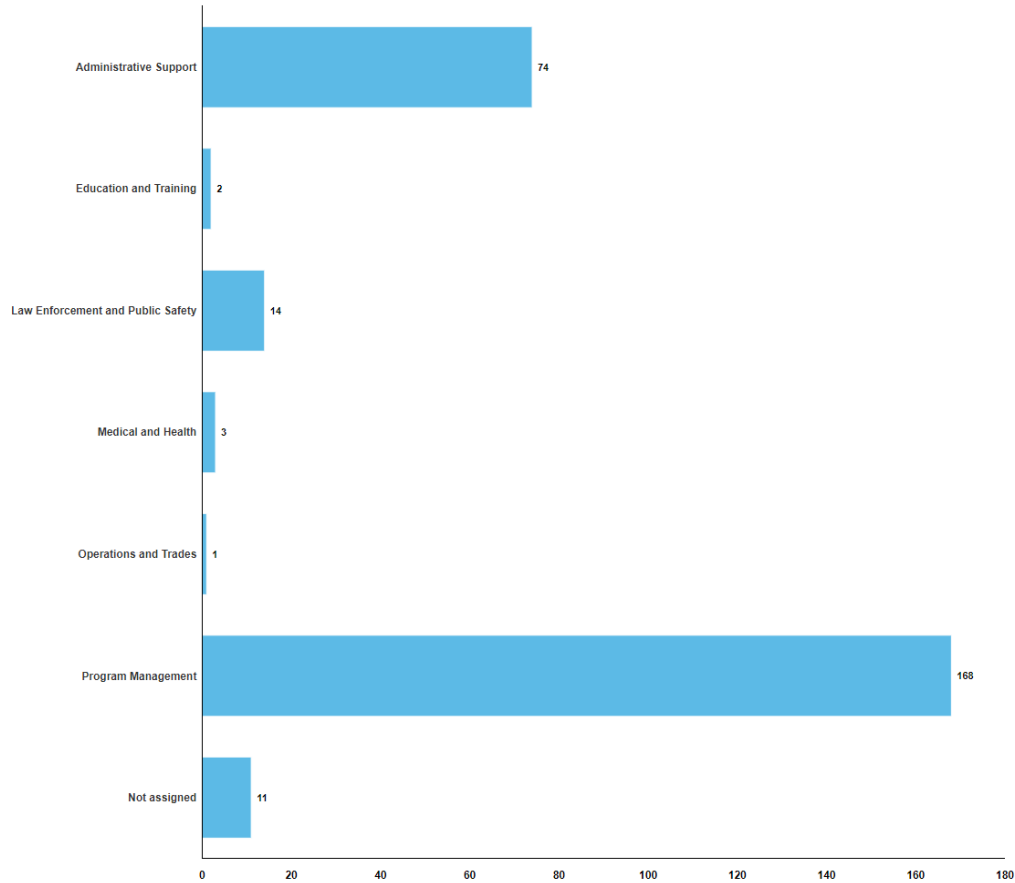

NCDOT Turnover 5/18 – 4/19

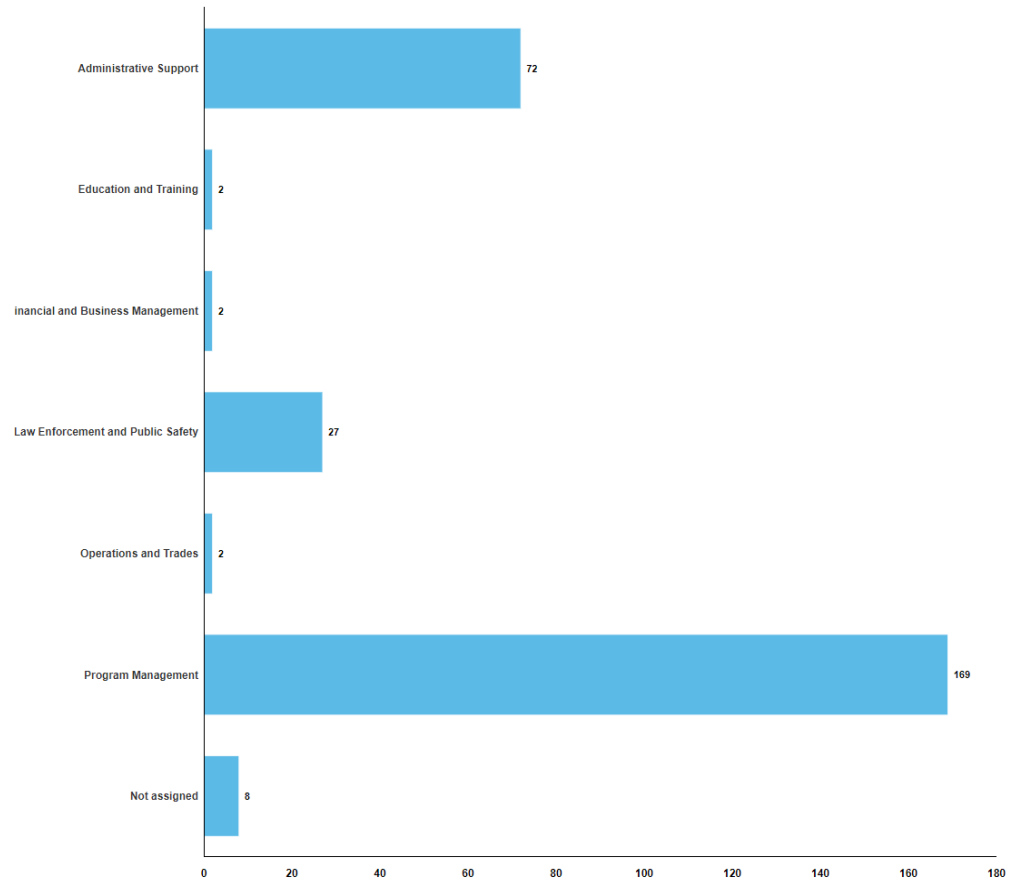

NCDMV Staffing - Retirement

NCDMV Retirements have the potential to increase more than 5X in the next 5 years.

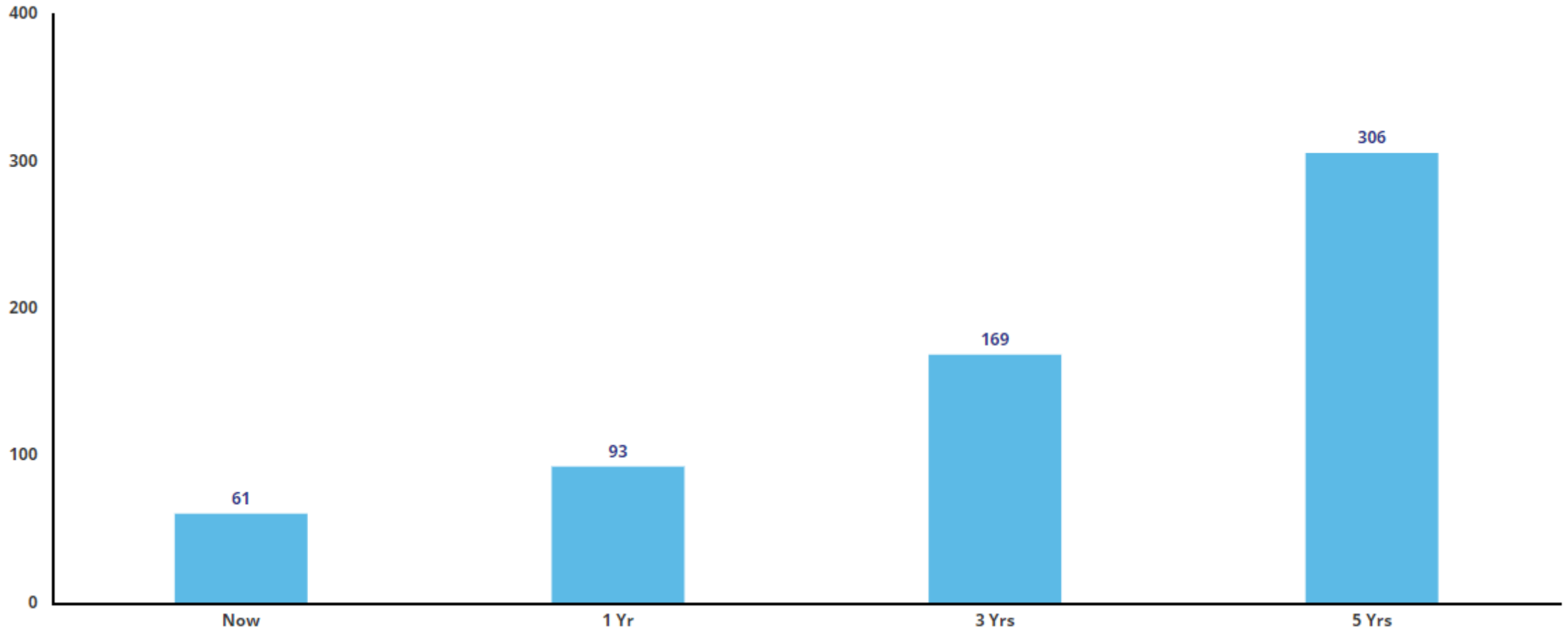

NCDMV retirements in Program Management, Law Enforcement, and Administrative Support are growing.

NCDMV Retirement Eligibility: 1 year

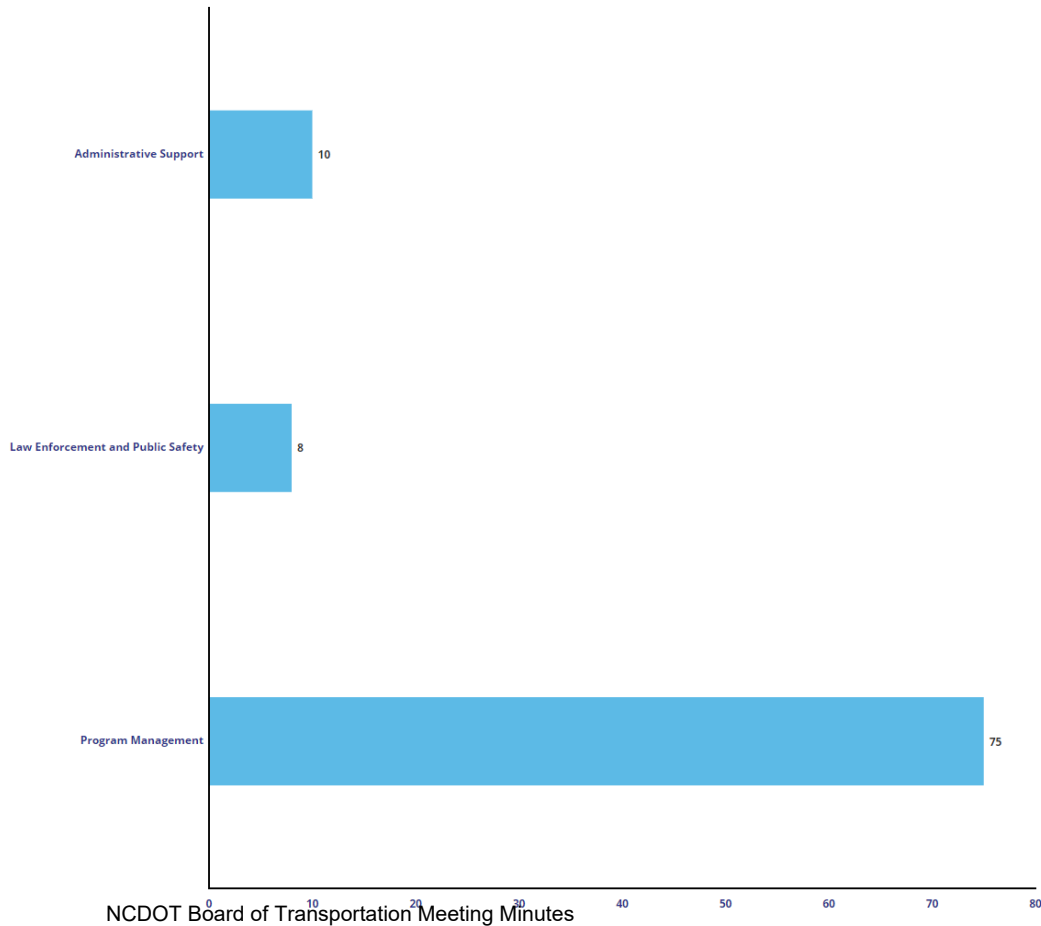

NCDMV Retirement Eligibility: 5 years

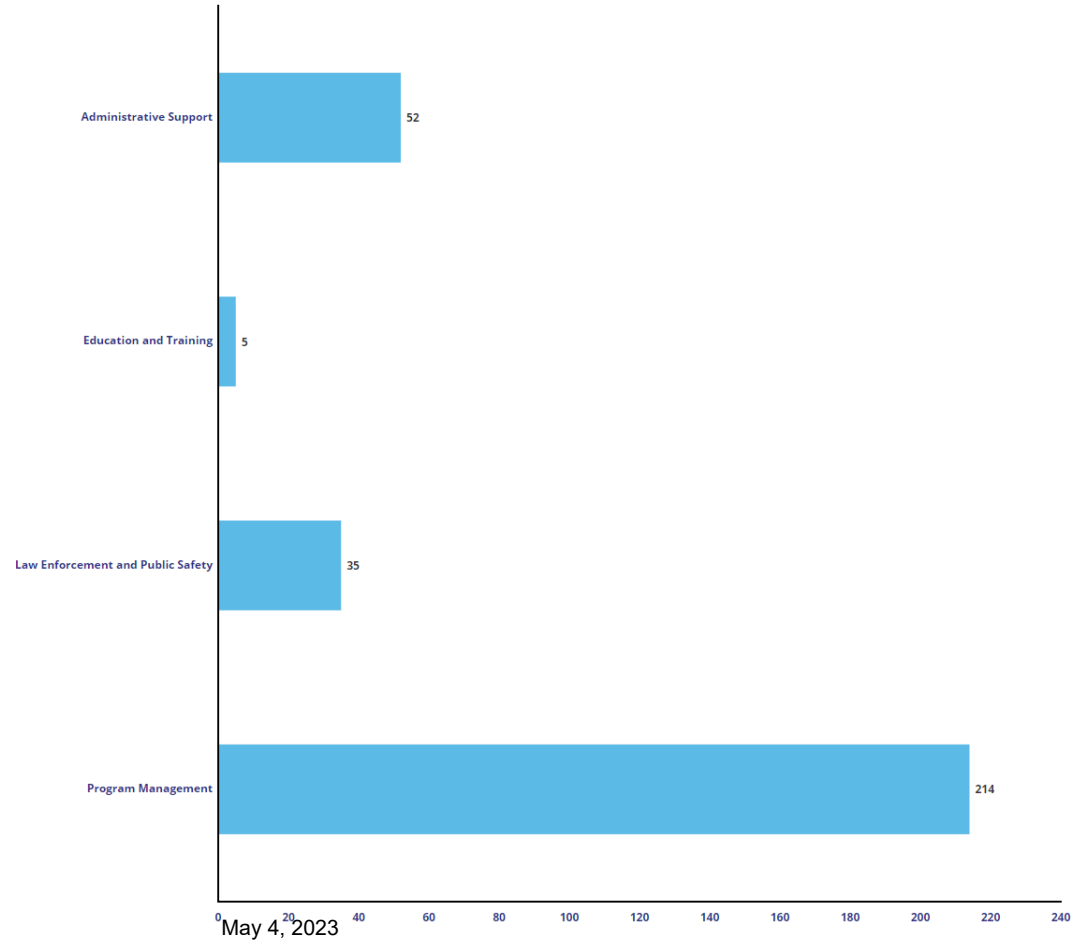

ServiceNow System Update

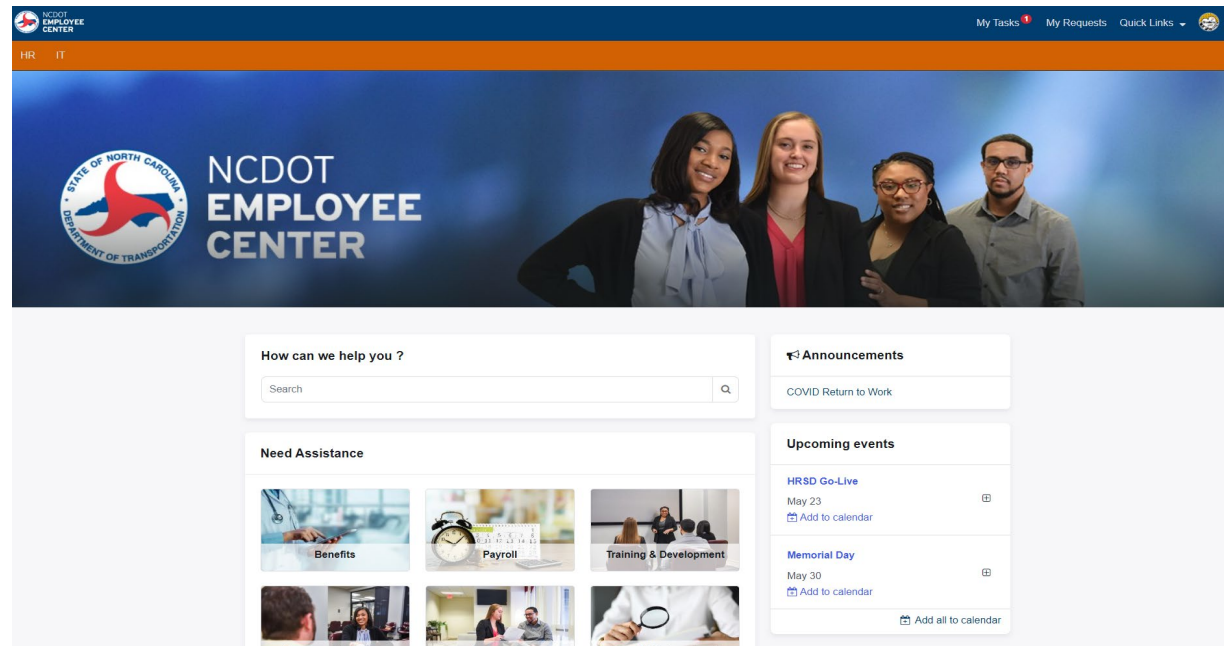

ServiceNow HR Timeline

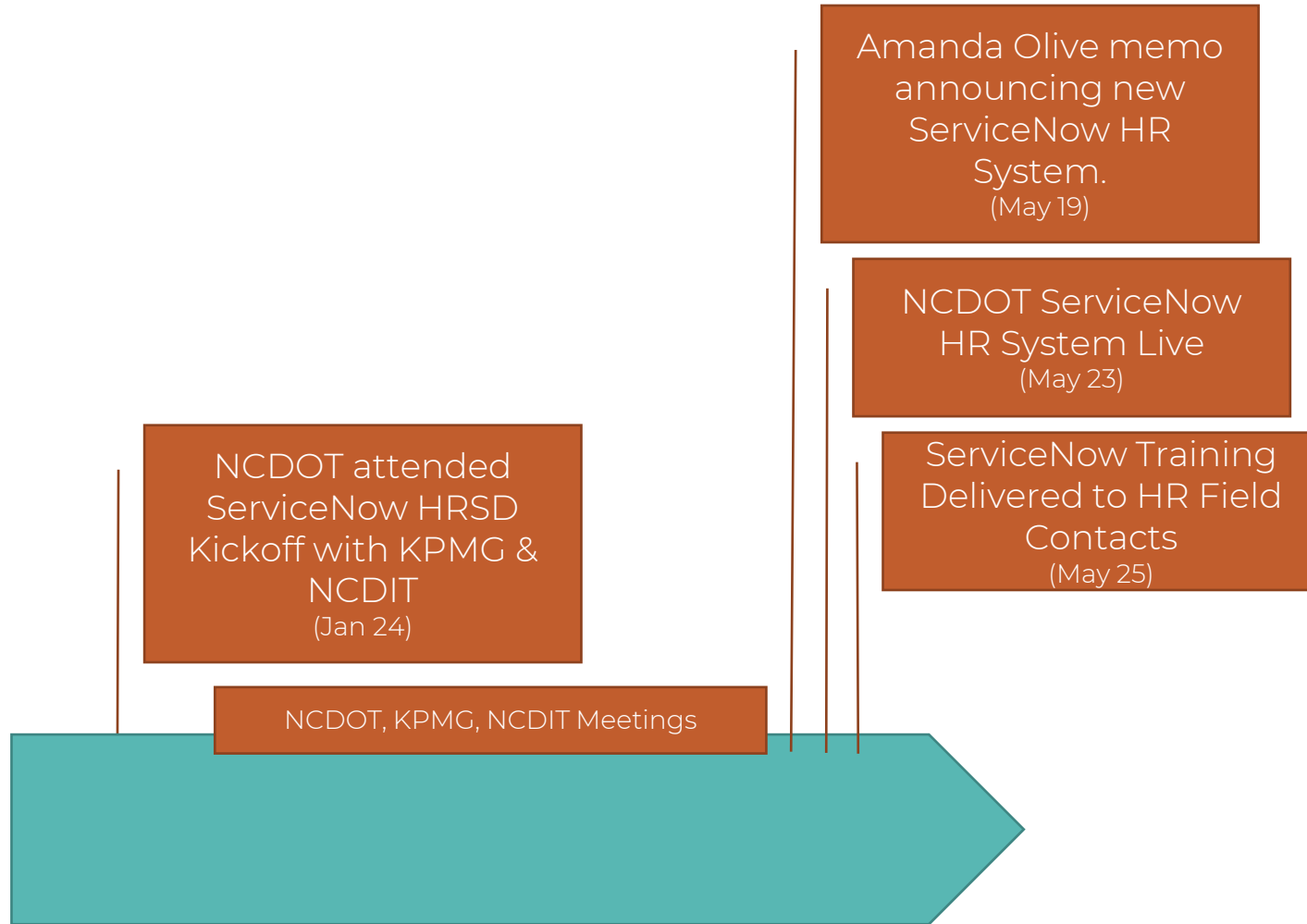

ServiceNow Status Update

- Laura Oakley, Manager, Salary Administration & Qualification Review recently conducted more extensive training regarding the hiring packages and the process in ServiceNow.
- The Employee Relations Team has entered numerous knowledge articles (policy guidance).
- The Salary Administration Team is processing the hiring packages using the ServiceNow Portal.
- Daphne Wright, Policy Manager, has been entering announcements and providing knowledge articles (policy guidance).
- Information in ServiceNow is growing, and some employees are suing the Employee Center to ask questions.
- Improvements are needed to make the tool easier to use and provide a secure way to handle HR functions.
- Looking at expanding usage for other processes such as Orientation/Onboarding.

NCDMV HQ- Bonuses

NCDMV Headquarters Move Bonuses Totaled \$97,500

Role	Bonuses	Total Bonuses Paid
• Administrative Specialist I	18	\$27,000
• Program Supervisor II	6	\$9,000
• Program Supervisor I	5	\$7,500
• Staff Development Specialist I	4	\$6,000
• Program Coordinator IV	3	\$4,500
• Program Coordinator III	3	\$4,500
• Program Coordinator I	3	\$4,500
• Administrative Specialist II	2	\$3,000
• Program Analyst II	2	\$3,000
• Administrative Associate II	2	\$3,000
• Program Analyst I	2	\$3,000
• HR Consultant II	2	\$3,000
• DMV LE Supervisor	1	\$1,500
• DMV Assistant Commissioner	1	\$1,500
• Nurse Supervisor I	1	\$1,500
• DMV Deputy District Manager	1	\$1,500
• DMV LE Manager	1	\$1,500
• Program Coordinator II	1	\$1,500
• Staff Development Coordinator	1	\$1,500
• DMV Director	1	\$1,500
• Business Officer II	1	\$1,500
• DMV LE Inspector II	1	\$1,500
• Program Director II	1	\$1,500
• HR Manager I	1	\$1,500
• HR Technician III	1	\$1,500
Total	65	\$97,500

NCDMV MVP Program

NCDMV Motor Vehicles Professional (MVP) Program



Mission

Prepare and develop future leaders with the training, skills, and experience to lead in NCDMV headquarters.

1. Engage emerging workforce in business-driven roles at NCDMV HQ.
2. Provide rotations for them to explore all that NCDMV has to offer.
3. Grow NCDMV's next-generation talent supply to be our leaders of tomorrow.



Questions?

I-42 / US 70 Corridor Commission Update

Board of Transportation Economic Development and Intergovernmental
Relations Committee

May 3, 2023



NORTH CAROLINA DEPARTMENT OF TRANSPORTATION
DIVISION OF HIGHWAYS
PROJECT DEVELOPMENT AND PROJECT MANAGEMENT UNIT

I-42/US 70 CORRIDOR
NC DOT PROJECT LOCATIONS
WAKE, JOHNSTON, WAYNE, LENOIR, JONES, CRAVEN, CARTERET COUNTIES



Date:
April 2023

Figure
1

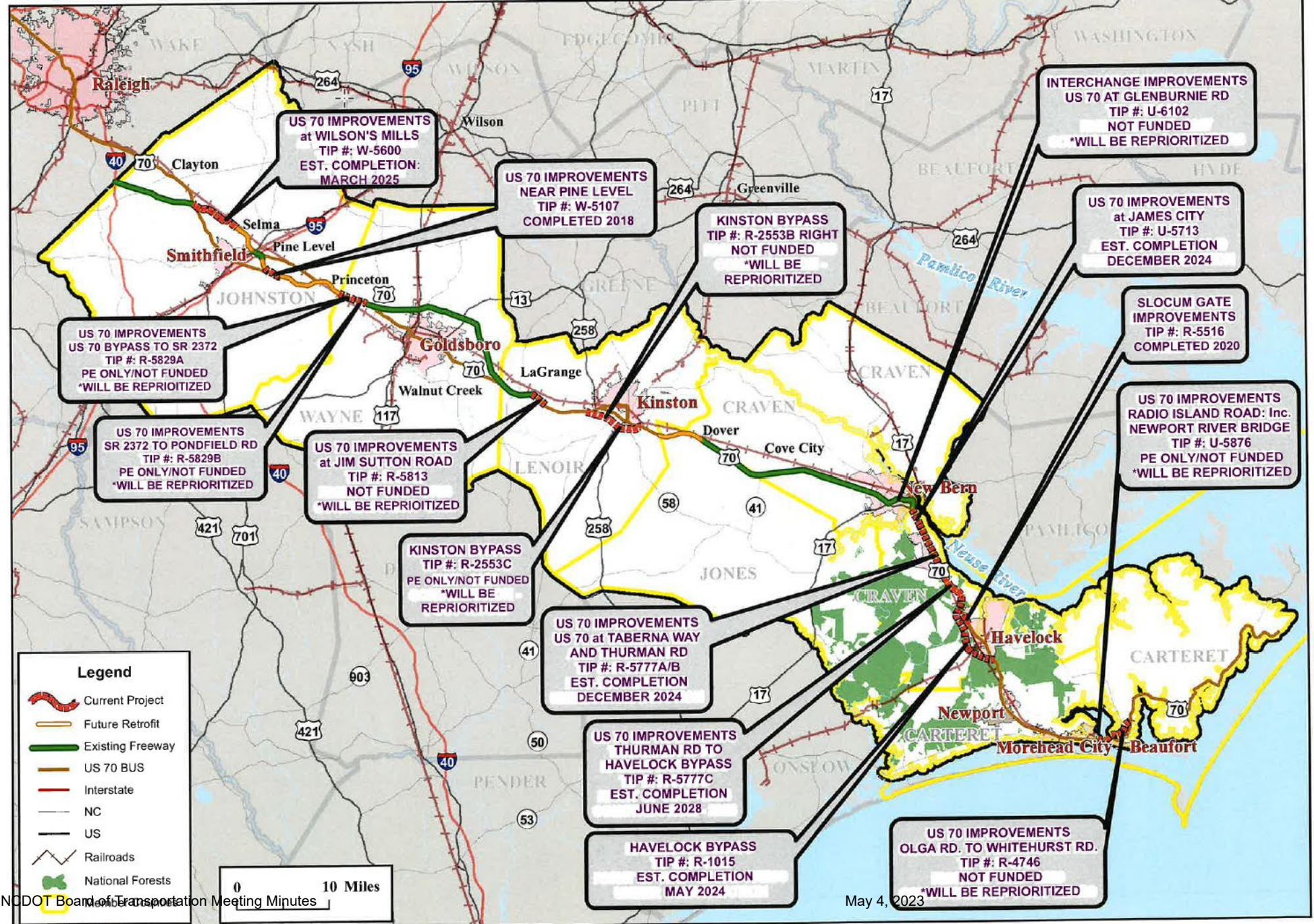



NORTH CAROLINA
Department of Transportation

Project Ranger

Project Status Update

Tim Anderson, P.E., Division Engineer, Division 13

Connecting people, products and places safely and efficiently with customer focus, accountability and environmental sensitivity to enhance the economy and vitality of North Carolina

Project Ranger HE-0001

Economic Impacts

Pratt and Whitney:

- Construct 1 Million square foot facility in Biltmore Park West
- Create **800 new jobs**
 - SUPPORTS **1,264** TOTAL DIRECT, INDIRECT, INDUCED JOBS
 - **\$74M** IN NEW PAYROLL
 - ANNUAL TAX IMPACTS: **\$2.5M** LOCAL | **\$6.1M** NC | **\$23M** US
- Invest **\$650 million** in real and business personal property
- Provide an **average wage of \$68K annually** (\$32.69 hourly).
- Aligns with Buncombe County 2025 Strategic Plan Goals for increasing average wages and total employment.

Regional Impacts

- Based on Pratt and Whitney's job creation plans, 800 out of the 800 proposed jobs qualify for the jobs incentive in the Buncombe County Economic Development Incentive Policy (greater than \$20.90 per hour, or \$43,472 per year).
- All 800 jobs exceed the 2020 "living wage" published by Just Economics (greater than \$15.50 per hour, or \$32,240 per year) for a full-time living-wage employee without health insurance.
- Community College is offering several technical courses, including CNC Machining 101, Machining Fundamentals, and a Certified Production Technician Program.
- On-site 20,000 square foot AB Tech training center dedicated to manufacturing technology.

Partnership

- Joint economic development effort between:
 - North Carolina Department of Commerce: economic development incentives (\$30M)
 - A-B Tech: customized training and training center
 - Golden Leaf Foundation: bridge infrastructure for access to NC 191
 - Biltmore Farms: land grant
 - Economic Development Coalition (EDC): project management
 - Community Betterment Foundation (CBF): grant administration
 - Buncombe County: economic development incentives
 - NCDOT
 - Appalachian Regional Commission (\$2.5 M for access Roadway)
 - US Economic Development Administration (\$2 M for access Roadway)
 - French Broad River MPO

Pratt and Whitney Construction Status

Pratt and Whitney Asheville Plant



Facility Status

Pratt and Whitney:

- The first phase is 95% completed
- The company is currently installing and qualifying machinery across the site
- Production planned to start in May

Pratt and Whitney The Product

Geared Turbofan (GTF) Engine

GTF ENGINE FAMILY
FOR LARGE COMMERCIAL AIRCRAFT
AND REGIONAL JETS

17,000 – 33,000
Pounds Thrust Class

16% Improvement in fuel efficiency

50% Reduction in regulated NOx emissions

75% Reduction in noise footprint

Pratt & Whitney geared turbofan

A geared turbofan engine has a gearbox between the front fan and the shaft to the engine core, so that the speed of the front fan can be decoupled from the speed of the core. This way, the engine can safely drive a larger fan and push a larger volume of air, while the low-pressure compressor and turbine blades spin faster, boosting fuel efficiency.

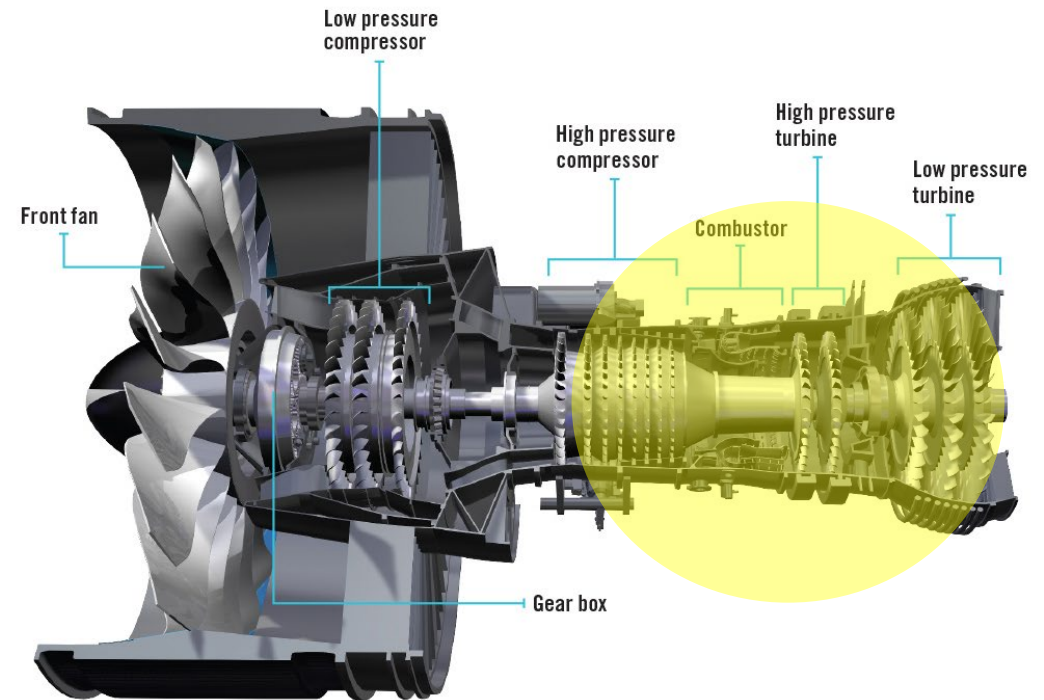

The Challenge

Getting to the Site

Site Constraints

- Bordered by I-26
 - Currently in an active construction project (I-4700) to widen I-26 to 8 lanes
 - There is a mountain between I-26 and the Site
- Bordered by the French Broad River
 - Mountain River
 - Heavy Tourism Component
 - No bridge to the site from NC 191 at the beginning of the project
- Bordered by the Historic Biltmore Estate on the East
- Bordered by the Blue Ridge Parkway
 - National Treasure
 - Significant Right of Way
 - View Shed Protection Standards
 - No Commercial Access Allowed
 - County Overlay District to control development in the vicinity of the parkway



Connecting People Places and Products

Initial Site Access

- Biltmore Farms constructed a bridge across the French Broad River and an access road to the site.
 - Golden Leaf Funds utilized for the bridge
 - Bridge constructed to accommodate a 4 lane roadway, pedestrian and bicycle infrastructure
- Bridge and roadway project began February 23, 2021
- Bridge and roadway were added to the State System during the March NCDOT Board Meeting.
- Total cost of the bridge was just under \$15M and the roadway portion was \$3.5M.





NCDOT's Project

I-26 Access for the Site

- NCDOT committed to constructing an interchange project to provide a much needed East/West connection from I-26 to NC 191 and access to the site.
- The project consists of constructing an interchange on I-26, and approximately 0.5 miles of secondary road and sidewalk to complete the connection to NC 191 and connect the Pratt Whitney site to I-26.
- Initial construction budget of \$30M.
- Timeline for delivery is Fall of 2025

I-26 Access Challenges

- I-26 is currently being widened through this area.
- Bifurcated section of I-26 has very stringent environmental commitments as part of the permit for I-4700
- The Parkway Staff has a very focused mission and were included as part of the merger process.
- The only viable location for an interchange is mountainous, and initial reviews indicate substantial rock within the grading pattern.
- Material Cost Escalation
 - We have pulled in Appalachian Resource Commission funding and we are seeking Economic Development Administration funding to help offset some of the material escalation costs.
 - Regularly researching value engineering options to defray costs and keep the project on schedule.
- Bat Moratorium

Bat Moratorium Stats



- Affected species: Northern Long-Eared Bat and Gray Bat
- Restricts tree clearing operations and night work
- Prohibited from clearing trees between March 14th and November 15th

**Fun with Friends
The Blue Ridge Parkway Staff**



Can you guess what is in the box?

View Shed Visualizations Required for the Parkway



View Shed Visualizations Required for the Parkway

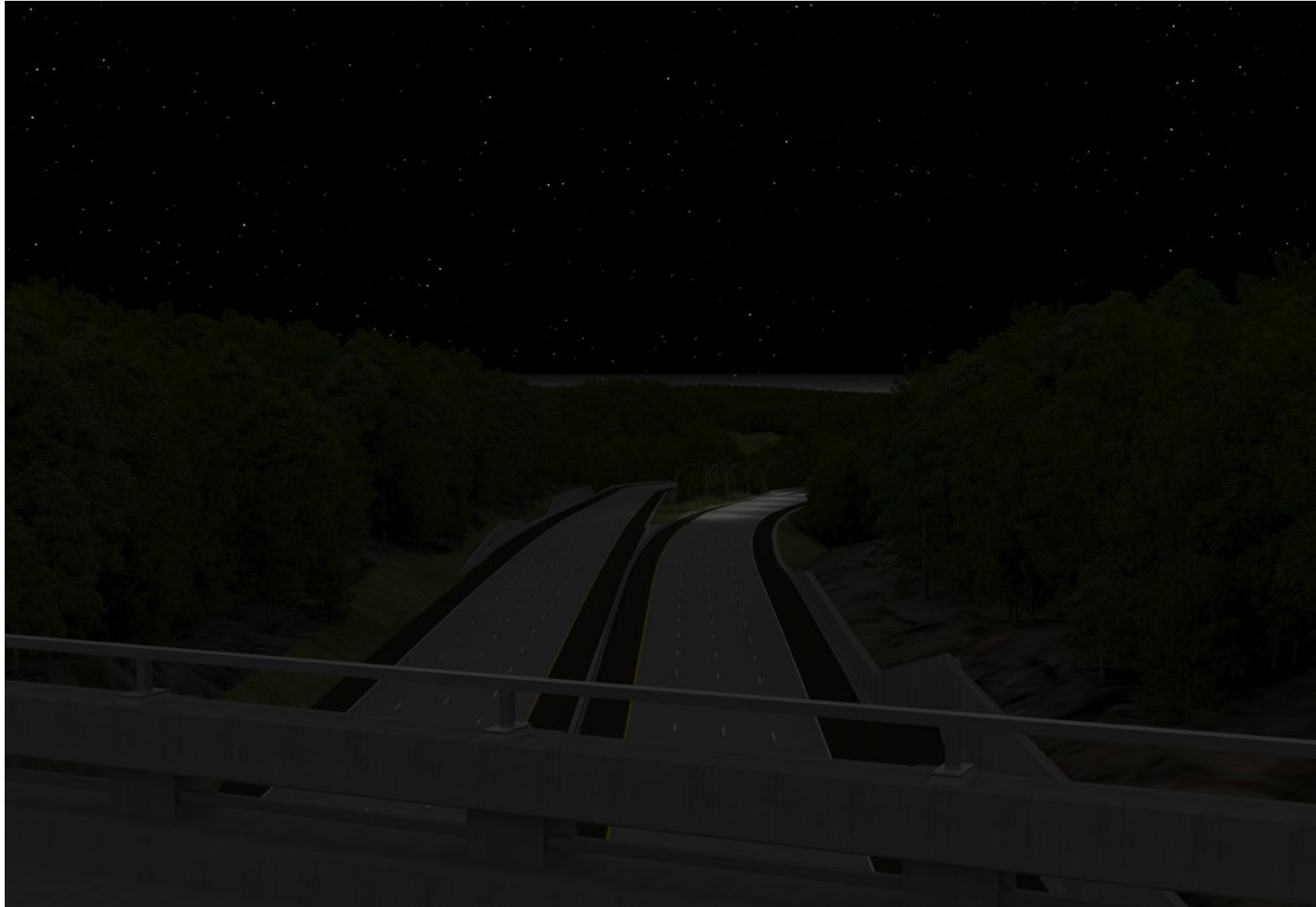

Design Options

I-26 Access for the Site

- Several options were considered for the interchange design.

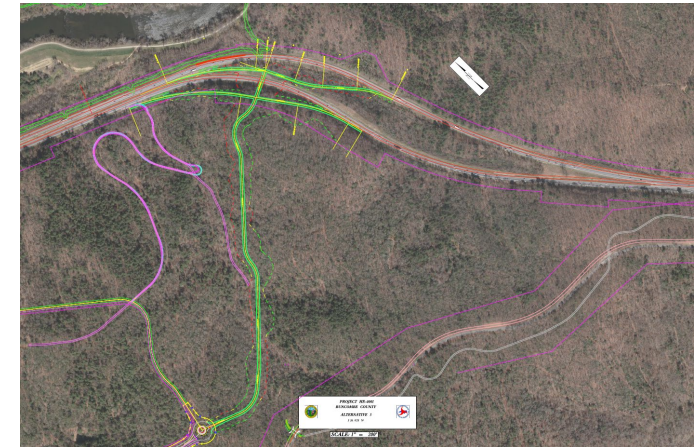
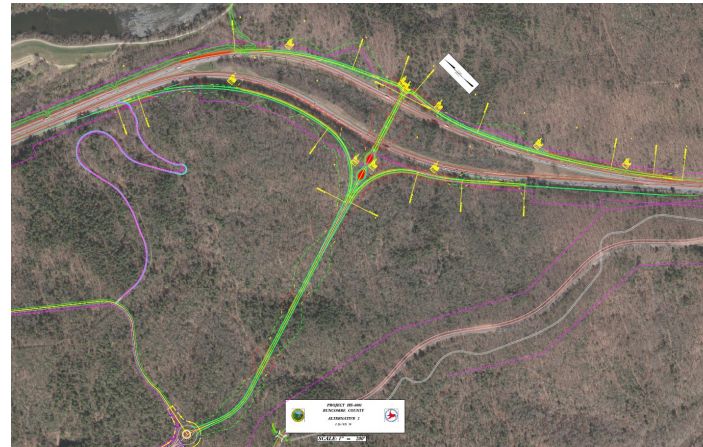
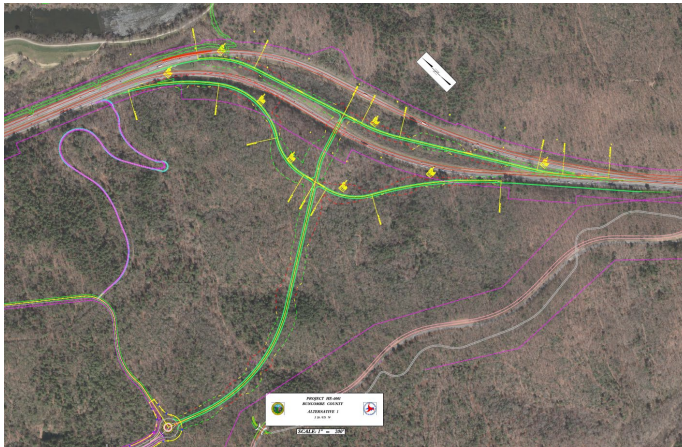

- Site constraints and recognition that the East side of the interstate will not develop (Historic Biltmore Estate) required a unique solution.



Selection Benefits

- Left lane entrance/exit on the westbound approach reduces the foot print of the project and keeps us within existing right of way beside the Biltmore Estate.
- NCDOT and FHWA collaborated on the left exits to ensure that the design met federal standards and the Interstate Access Request was approved.
- Diverging Diamond Interchange on the bridge reduces projected congestion and reduces the need for signalization to one intersection.
- Diverging Diamond design also increases the efficiency of the interchange.

Current Status

- We completed the merger process January 25, 2023.
 - The merger team was very diligent and completed merger in 18 months (typically 24 to 48 months).
 - Shout out to John Jamison, Unit Manager, Environmental Policy Unit, and his team with NCDOT and Donnie Brew, Preconstruction & Environment Engineer with FHWA.
 - Their work to keep all parties focused and at the table was instrumental in reducing merger time
- The design firm is working on 65% plans and focusing on strategic items on the project.
- An application for an individual permit for the project will be submitted by the end of the month, with anticipation of the permit by mid-summer.
- If the current plan for delivery is successful, It is anticipated the project will be completed by Fall of 2025.

Special Appreciation

- McCray Coates, P.E., Project Manager for the first part of this project.
- Brendan Merithew, P.E., Division Project Team Lead who is carrying the project to let.
- Nathan Moneyham, P.E., Division Construction Engineer for diligent work to reduce the impacts and keep the project on schedule.
- Merger Team for a fast turnaround with some very complex issues.
- Chief Chris People's office for supporting innovative approaches to delivery and strategy sessions.
- Donnie Brew – FHWA
- John Jamison and his outstanding Environmental Policy Unit team.
- Tim Love, Buncombe County Manager's office for slide info.
- Tom Sri, with Raytheon for the aerial photo of the site.

Questions?

Thank you!

Contact Us

Tim Anderson, P.E., Division Engineer

twanderson@ncdot.gov

828-250-3000



 @NCDOT

 NCDOT

 NCDOTcommunications

 @NCDOT

 ncdotcom

 ncdot_comm

A hand is shown pointing at a futuristic digital interface. The interface features several glowing icons: a car, a battery, a satellite, and a microchip. The background is a dark blue with various data visualizations, including a bar chart, a line graph, and a map. The overall aesthetic is high-tech and futuristic.

Our Roadmap to the Connected Vehicle World

James “J.J.” Eden
NCTA Executive Director

Chris Garlick
NCTA Director of Innovation and Strategy

Today's Agenda

- Mobile and Connected Vehicle “first” design
- Our Accomplishments
- Building a Platform for Connected Vehicles
- Next Steps /Open Questions

A change in our design thinking is required



A Connected World

- Nearly 300M smart phones in the United States.
- Connected Vehicles are already 1/3rd of existing fleet
- Infotainment system design will allow vehicles to be the next payment method.
- Data can be used from connected vehicles to plan, design and operate roadways today.



YEARS IN THE ROAD

North Carolina Turnpike Authority

2008

Conducted video shootout to test new video technology now widely used in tolling and law enforcement.

2011

NC Quick Pass All Electronic Tolling (AET) program launched

2014

Most Interoperable Tolling agency from Maine to Florida

2017

First Tolling agency to read all three transponder protocols being considered for national interoperability

2019

Established a vision for service -based architecture and begin transition to cloud and service offering

2021

Lead tolling to transition transponder fulfillment as a service in the marketplace.

Participate in pilot programs for mileage -based user fees

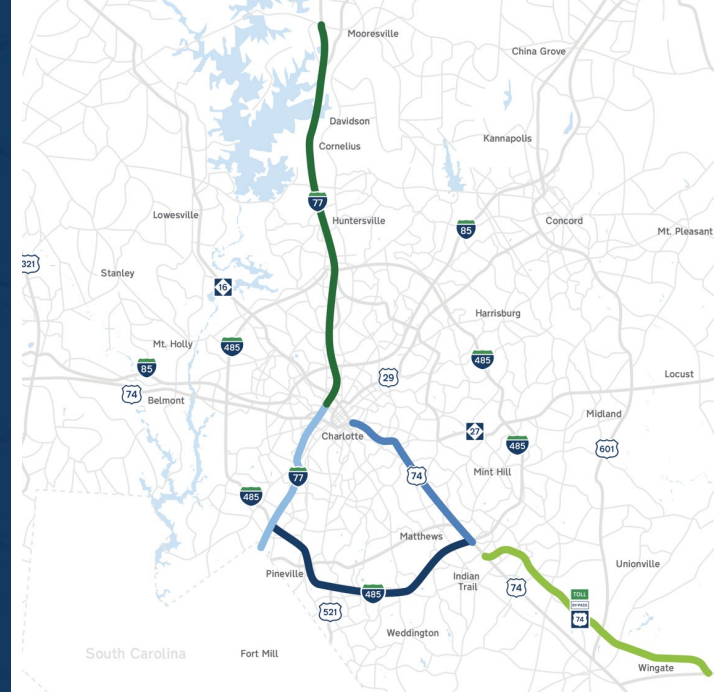

Raleigh Area

- Triangle Expressway**
Open to traffic
- Complete 540 Phase I**
Under construction
- Complete 540 Phase II**
Under development



Charlotte Area

- Monroe Expressway**
Open to traffic
- I-77 Express Lanes**
Open to traffic
- I-485 Express Lanes**
Under construction
- U.S. 74 Express Lanes**
Under development
- I-77 South Express Lanes**
Under development

Mobile App Pilot Launch



Benefits to our customers

- Ease of accessibility
- Get a real-time experience: with GPS-enabled trips
- Easily track toll expenses
- Real-time toll prices and travel conditions

Benefits to NC Quick Pass Program

- Guaranteed Toll payment
- More customers/fewer invoices
- Brings Efficiency to Toll posting
- Exemplifies Turnpike Platform Vision of service model



Source: <https://www.GoToll.com>

PaybyCar App Pilot Launch

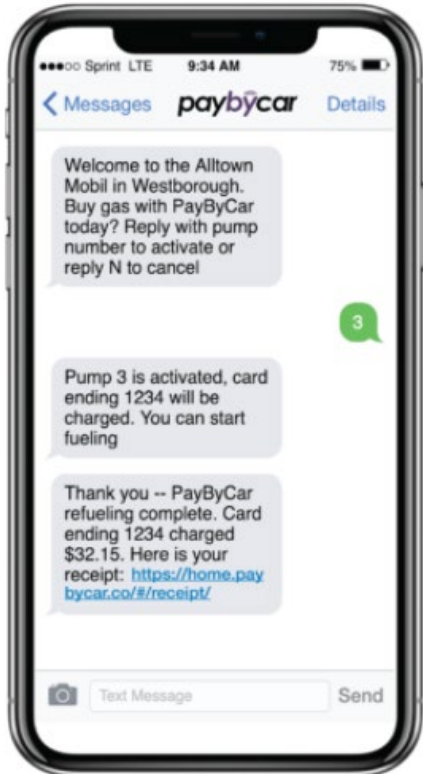

Benefits to our customers

- Simple and easy to use APP
- Get a real -time experience
- Pay for non -toll payments
- Easily track your non -toll expenses

Benefits to NC Quick Pass program

- Single RFID in car serving different uses
- Alternate mobile payment options

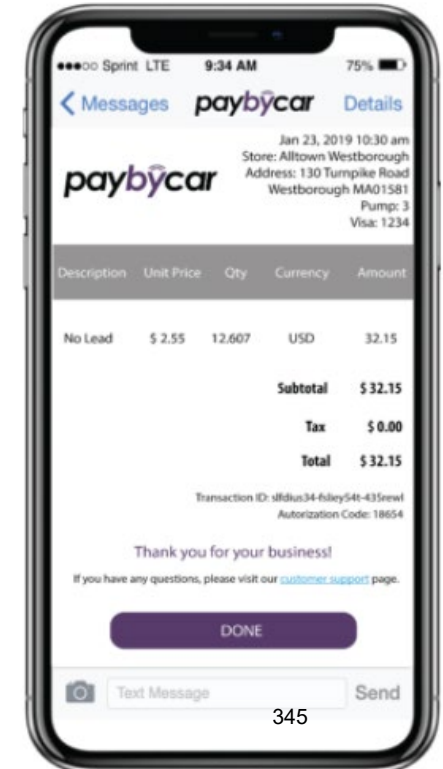

Connected Vehicle Data Marketplace

- Directly from vehicle OEM
- Available under 30 seconds or less
- Data secure and fully GDPR compliant
- Ignition on to off and every 3 seconds in -between
- Flexibility – define your volume & regularity

CV Data Planning and Operations

- Morrisville Parkway Interchange
 - 1) Prior to opening
 - 2) Opening before tolls
 - 3) After tolls operations
- Statewide Traffic by Region during COVID-19

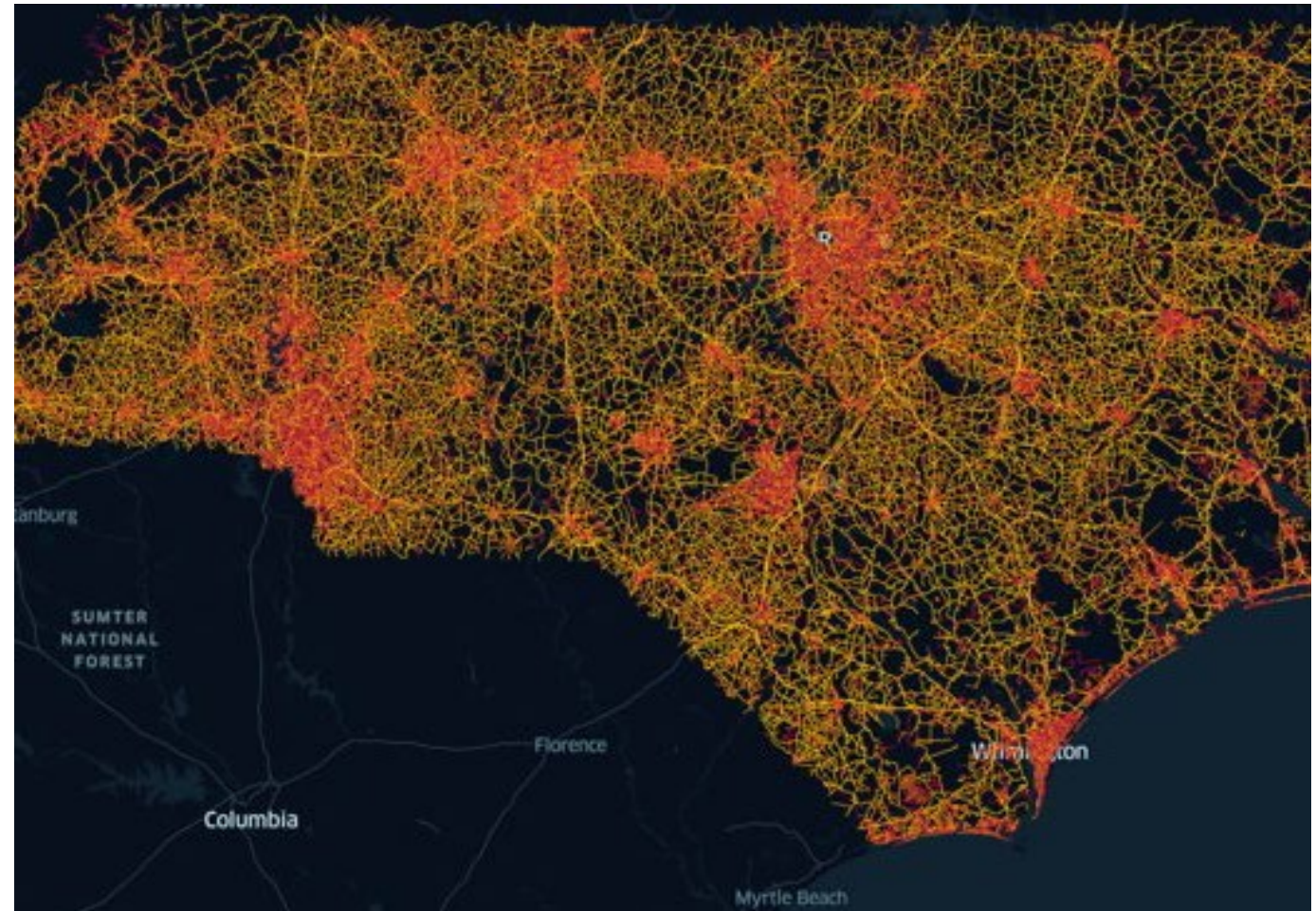

Some Questions for You

A hand is shown pointing at a futuristic digital interface. The interface features several glowing icons: a car, a battery, a satellite, and a microchip. The background is a dark blue with various data visualizations, including a bar chart and a line graph.

What will cars be like in 5 years?

How will mobile payments influence the tolling market?

What is the transportation industry doing or not doing to prepare for the future?



“

The way to
get started
is to quit
talking and
begin doing

”

– Walt Disney

Building an Open Platform Our Vision/Goals and Approach

Our Vision for a Platform

- Build a Platform not a product - “Roku” of Transportation.
- Create a platform for Connected Vehicles.
- Be product agnostic and create platform for multiple service providers.
- Design for the customer journey including non -tolled services and be more inclusive to all drivers.
- NCDOT Board of Transportation Meeting Minutes Transition is an “Evolution not a Revolution”. May 4, 2023

In-Vehicle Infotainment – Smartphone on Wheels



NCTA Customer Centric Payment Platform

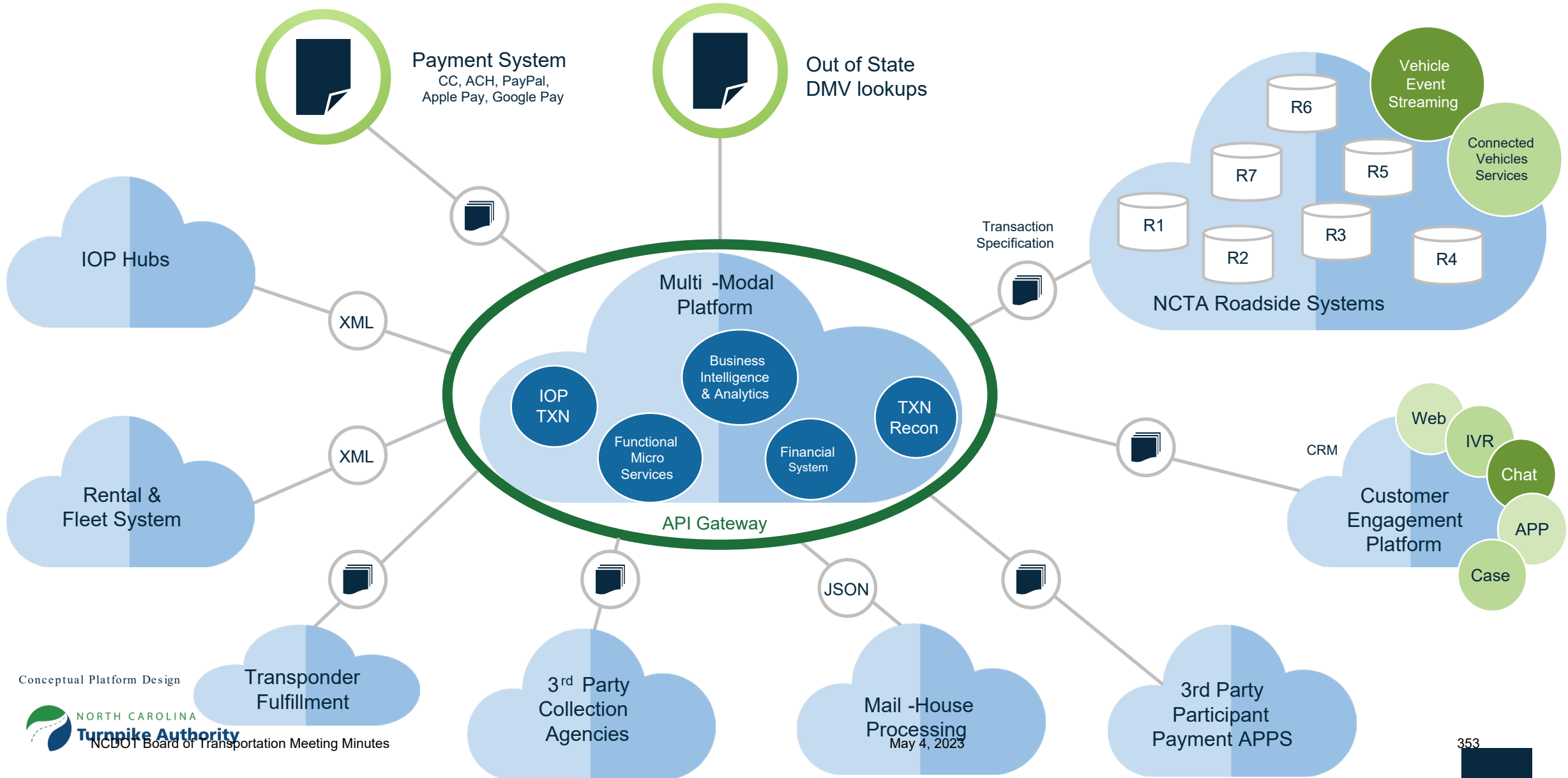

Conceptual Platform Design



NCDOT Board of Transportation Meeting Minutes

How do we transition?

- Design for the customer journey
- Unbundle custom applications
- Leverage COTS and other financial services



Unbundled Domain Example

Account Profile and Account Access	Account Maintenance	Payments	Customer Correspondence and Invoice	Case Management	Location Services (WIC,Retail)	Toll Interoperability (NIOP)	External Business Systems
<ul style="list-style-type: none"> • Add / update Name (first and last) • Add /update email • Create/Update Username • Create/Update Pin • Create / Update Password • Reset Password • Connect / remove external account • Add security Questions • Get Account information (single or bulk) 	<ul style="list-style-type: none"> • Create Account • Close Account • Add / Update / Remove demographics (Contacts, Address, Email, phone) • Add /Update/ Remove Vehicle identifier (plate/ Transponder/VIN) • Add/update/ remove discount plan • Add/Update/ remove account suspension date • Get /Send Account Balance • Update Statement Type 	<ul style="list-style-type: none"> • Add New Payment (create Token) • Update Payment Method • Remove Payment Method • Add Replenishment • Update Replenishment • ACH Authorization • Update Replenishment threshold • Connect ewallet 	<ul style="list-style-type: none"> • Send / Receive Correspondence data • Get mailed data • Get document • Get updated address information • Get exceptions (not sent) • Send(Put) correspondence data to external source • Send(Put) correspondence data to external source • Send SMS/Email 	<ul style="list-style-type: none"> • New / Update Case • Get Cases (in Account) • Update Case Status • Add Comment to Case • Add Attachment to Case • Remove Attachment from Case • Download Attachment from Case 	<ul style="list-style-type: none"> • Locator ID (Retailer / Roadway / Service Plaza) • Name • Type • Photo • Street View • Services available 	<ul style="list-style-type: none"> • Send Interoperable Transactions • Receive Interoperable Transactions • Update Interoperable Transactions (Corrections) • Send Vehicle Identification Data (LP/TP) • Receive Vehicle Identification Data (LP/TP) 	<ul style="list-style-type: none"> • Get ROV lookup • Get Image Verification Service lookup • Get Address Standardization • Send/ Receive 3rd Party Collections payments

Payment Gateway

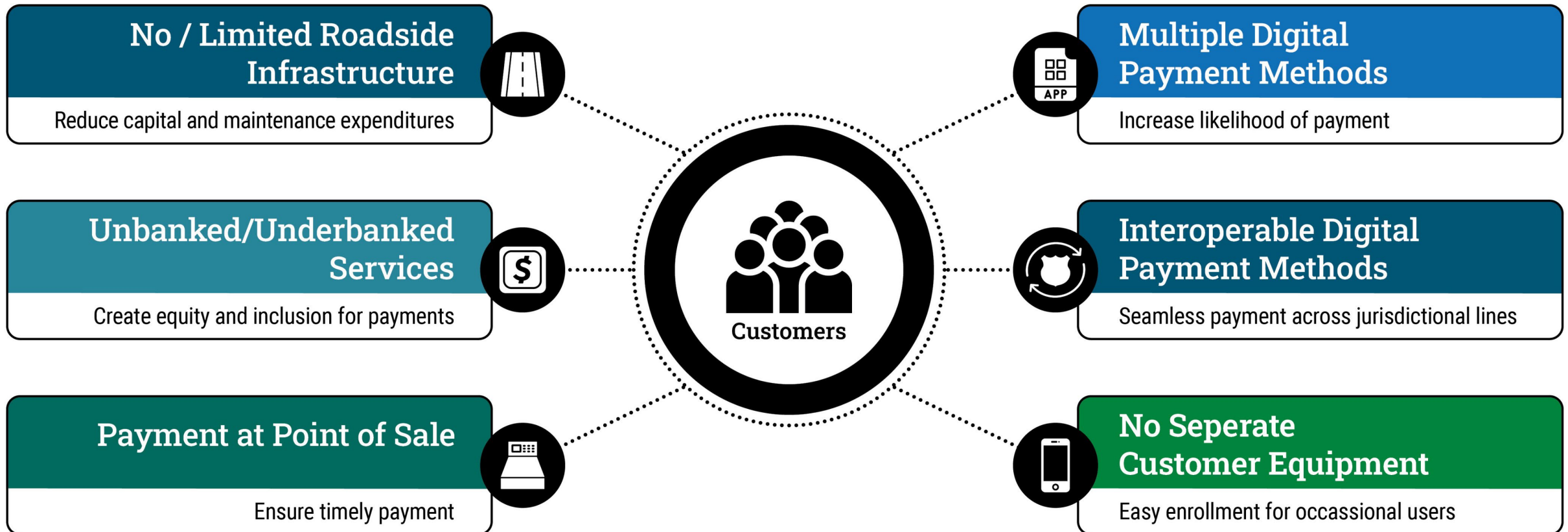

Participating Toll Agencies

- Bay Area Toll Authority/ Metropolitan Transportation Commission
- Central Texas Regional Mobility Authority
- Colorado Transportation Investment Office
- E-470 Public Highway Authority
- Florida Department of Transportation
- Halifax Harbour Bridges
- Harris County Toll Road Authority
- Illinois Tollway Authority
- Indiana Toll Road Concession Company, LLC
- Kansas Turnpike Authority
- New Jersey Turnpike Authority
- North Carolina Turnpike Authority
- North Texas Tollway Authority
- Ohio Turnpike and Infrastructure Commission
- Oklahoma Turnpike Authority
- Pennsylvania Turnpike Commission
- Port Authority of NY & NJ
- Southern Connector
- Thousand Island Bridge Authority
- Tampa Hillsborough Expressway Authority
- Washington State Department of Transportation

Digital Payment Gateway Approach

- Develop framework for solutions that support one or more payment interfaces.
- Target commercially available tools with common and defined industry standards.
- Providers and bundled solutions may be different based on each provider but with the same interfaces with agency.

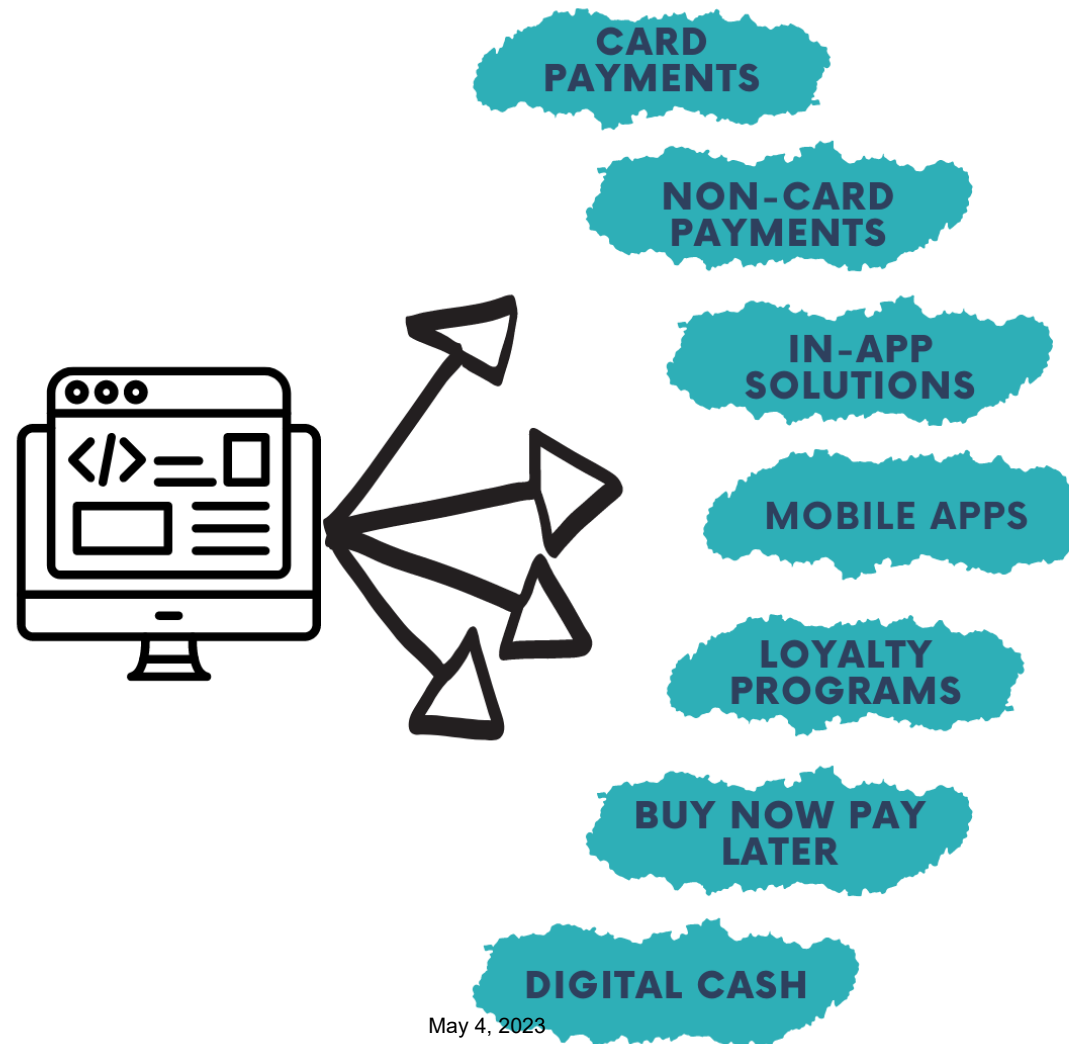

What have we learned so far?

1. Consumers expect merchants to meet them in their journey and accept their preferred payment method.
1. Their experience is everything and if they get distracted or there is a system error, we need to reach out to try again to successfully make payment.
2. Consumers expect multiple digital options, and we must facilitate them to stay in digital channels.
3. Payment systems are becoming more distributed, and consumers have a choice in open banking.
4. No one solution fits all and standards are needed to leverage multiple solutions.



Next Steps



- Short term (<1 year)
 - Complete Backoffice transformation to include open interfaces(API) on platform.
 - Develop industry standards for payment and customer experience interfaces that include Connected Vehicle.
 - Connected vehicle student engagement (Fall/Winter 2023)
- Long Term (1-2 years)
 - Support Connected Vehicle transformation.
 - Expand regional digital payment options with partners.

Rethinking our Approach

“It ’s often easier to make something 10 times better than it is to make it 10 percent better.” - Astro Teller



Contact Us



ncdot.gov

ncquickpass.com



[@NCTurnpike](https://twitter.com/NCTurnpike)

[@NC_QuickPass](https://twitter.com/NC_QuickPass)



jjeden@ncdot.gov



NORTH CAROLINA
Department of Transportation

Office of HBCU Outreach Update NCDOT Workforce Committee Meeting

N.C. Department of Transportation Deputy Secretary for Business
Administration, Ebony Pittman

May 3, 2023

Connecting people, products and places safely and efficiently with customer focus, accountability
and environmental sensitivity to enhance the economy and vitality of North Carolina



THE HBCU OUTREACH INITIATIVE STRATEGIC PLAN FRAMEWORK

MISSION: To create inclusion and opportunities for HBCUs/MSIs in the transportation industry.

VISION: Expand and diversify the transportation industry through the power of inclusion, and by strengthening the sustainable impact of North Carolina’s Historically Black Colleges and Universities.

PURPOSE

INFORM

PREPARE

CONNECT

WORK

SUSTAIN

STRATEGIC PRIORITIES

Expand Diversity in the Transportation Industry Through Employment and Contracting

Value and Promote a Culture of Diversity and Inclusion at NCDOT

Establish Strategic Alliances and Advocacy Efforts

Strengthen the Sustainability of North Carolina’s HBCUs/ MSIs

Connect HBCUs and Minorities with Emerging Trends in Transportation

OPPORTUNITY

The Office of HBCU Outreach

Strategic Plan and Core Programs

- HBCU/MSI Fellowship Program
- HBCU/MSI Internship Program
- SummerSTEM Program
- HBCU/MSI Scholarship Program
- HBCU/MSI Research Consortium
- National Summer Transportation Institute
- HBCU Alumni Employee Resource Group



INTERNSHIP PROGRAM

Open to students attending a

**NORTH CAROLINA
HBCU OR MSI**

who meet the following criteria:

- Currently enrolled or recent graduate**
- 24 credit hours completed**
- Minimum GPA 2.5**



FELLOWSHIP PROGRAM

Open to students attending a

NORTH CAROLINA HBCU OR MSI

who meet the following criteria:

- ✓ **Recent graduate with bachelor's or master's**
- ✓ **Must have graduated within the past three years**
- ✓ **Minimum GPA 2.5**



SCHOLARSHIP PROGRAM

Open to students attending a

**NORTH CAROLINA
HBCU OR MSI**

who meet the following criteria:

- ✓ **24 credit hours completed**
- ✓ **Minimum GPA 2.5**
- ✓ **Currently enrolled**





National Summer Transportation Institute

- NSTI Bridge Competition Winner

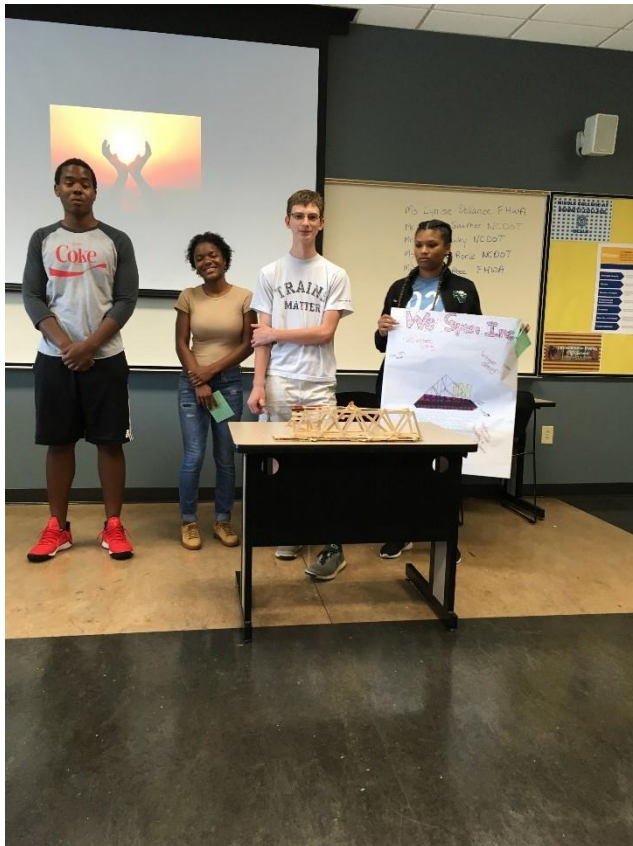

- NSTI Flying a Plane



- NSTI Construction Site Visit





NCDOT

SummerSTEM

2022

HBCU Alumni Employee Resource Group



OFFICE OF
HBCU
OUTREACH

Creating the Diverse Workforce Pipeline

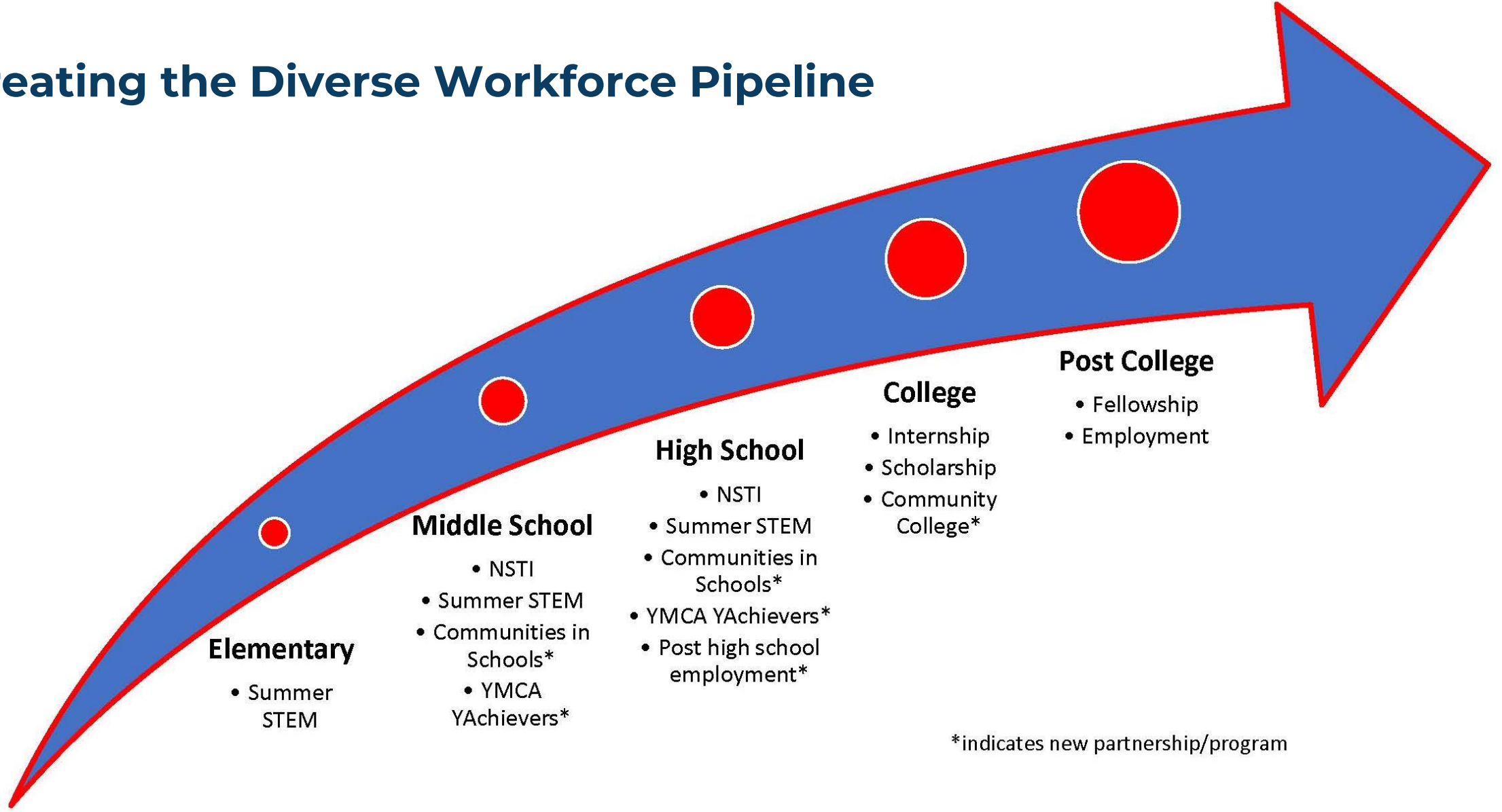

*indicates new partnership/program

Thank you!



NORTH CAROLINA
Department of Transportation

On-the-Job-Training and Equal Employment Opportunity Update

N.C. Department of Transportation Office of Civil Rights Director,
Tunya Smith

May 3, 2023

Connecting people, products and places safely and efficiently with customer focus, accountability and environmental sensitivity to enhance the economy and vitality of North Carolina

Developing a Skilled Diverse Workforce for North Carolina

On-the-Job
TRAINING

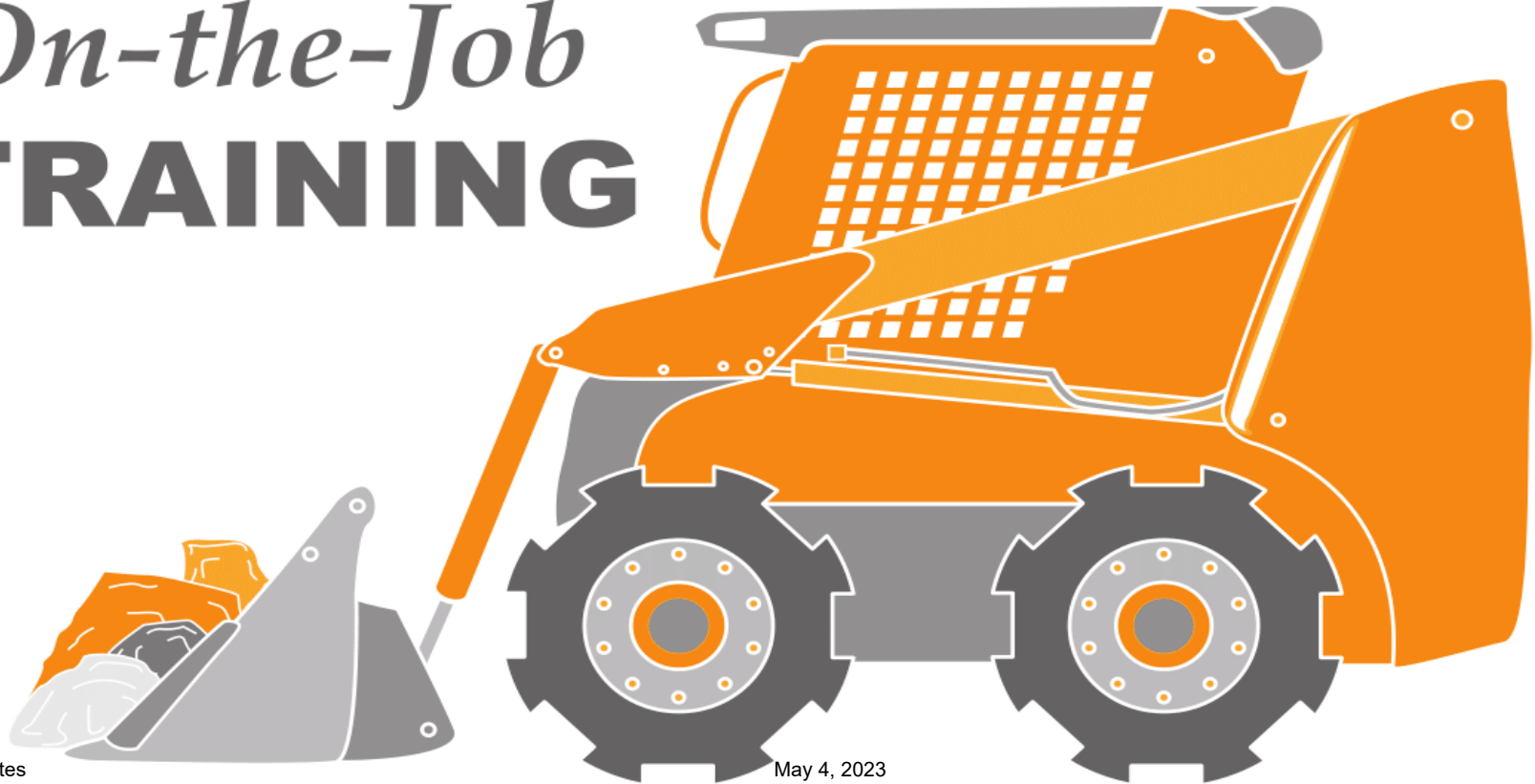

On-the-Job Training Program

Train minorities, women and disadvantaged contract workers to journey level



Highway Construction Trade Academies

Train members of the public from the targeted populations for entry-level jobs in the industry



Pop-up Academy



School Career Fairs

Wayne Education Network Annual Career Exploration Fair 2022



Hiring Events



2023 Transportation Summit

Workforce Zone



N.C. Commission of Indian Affairs Partnership



**North Carolina
Commission of
Indian Affairs**

OJT 2022-23 Accomplishments

- We had a record of 309 prime contractor employees enrolled into the OJT program as trainees in CY2022.
- This was due to a new formula and methodology that included division-let contracts resulting in a goal of 319. The goal for CY2023 is 219 due to the three-year running average calculations.
 - 34 contractors participating in the OJT compliance program for 2023.
 - 78 new enrollments as of March 30, 2023 (Total active 194 including 2022 carry-overs).
 - 23 graduates to journeyman status (individuals would have completed their upgraded skills classification training program hours).
- We'll continue to enhance the SharePoint system for OJT, create a position, and hire a full-time permanent OJT program compliance coordinator.

OJT/SS 2023 Accomplishments

- NCDOT OCR's OJT/Supportive Services unit was invited by the FHWA Office of Innovation and Workforce Solutions to present our innovative uses of 504(e) funds during a national training webinar. Our Deputy Director joined State Transportation Agency representatives from Michigan and Nebraska on the panel.
- Worked with National Governor's Association Technical Assistance project: utilizing fund flexibility of IIJA for workforce development including pre- and registered apprenticeships and high school summer accelerator concept.
- Pilot transportation summer accelerator program being developed for select public school systems across N.C. Partners include NCDPI, NCBCE, Community colleges, local education agencies and NCWorks.

OJT/SS 2022-23 Accomplishments

- Awarded a \$1.3M Digital Equity Grant from NCDIT to provide devices and related training to hundreds of OJT and Business Opportunity and Workforce Development program participants.
- OJT/Supportive Services has recently applied to have the new Transportation Summer Accelerator program (with high school students) be included as an Every Day Counts-7 initiative NCDOT's Transportation and Innovation Council and FHWA



NORTH CAROLINA
Department of Transportation



N.C. DEPARTMENT OF TRANSPORTATION
Office of Civil Rights

Equal Employment Opportunity Program Report

Connecting people, products and places safely and efficiently with customer focus, accountability and environmental sensitivity to enhance the economy and vitality of North Carolina



EEO Recent Accomplishments

- March 1 Submitted EEO State Plan to OSHR
 - “Your 2023 EEO Plan is *excellent*.” “DOT definitely has it going on!!” (OSHR staff)
- EEO and Service Now development underway
- Hired EEO investigator, interviews for one more investigator position will be happening soon
- Backlog of EEO cases has been cleared up



Workforce Best Practices

- Quarterly reports to NCDOT business units
- EEO on-site evaluations
- Disciplinary actions annual report
- Diversity, equity and inclusion, (DEI) focus at NCDOT
- Training: Equal Employment Opportunity and Diversity Fundamentals (EEODF), required for each new supervisor and Fundamentals of Management is required annually
- Review and approval of hiring packages: EEO Unit approved 3,075 hiring packages during 2022

Connecting people, products and places safely and efficiently with customer focus, accountability and environmental sensitivity to enhance the economy and vitality of North Carolina

Workforce At A Glance

Q3 Total Employees: 8,628

- Females: 2,018 (23.4%)
- Minorities: 1,987 (23%)
- Disabled Persons: 183 (2.1%)
- Veterans: 488 (5.7%)



Workforce At A Glance

Q4 Total Employees: 8,643

- Females: 2,031 (23.5%)
- Minorities: 2,005 (23.2%)
- Disabled Persons: 189 (2.2%)
- Veterans: 475 (5.5%)



Workforce Representation Trends

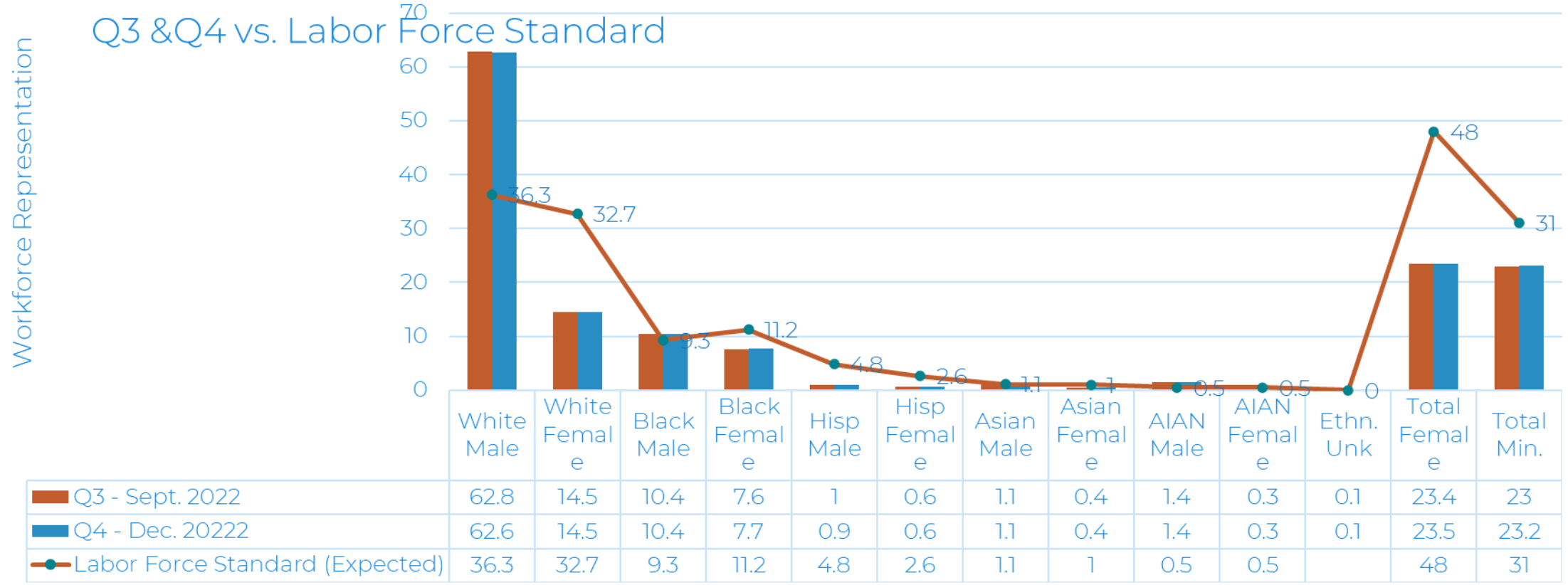

Source: IHRPS (Integrated HR Payroll System) B0178(f) Census Report; B0178 does not breakdown Two+ or Native Hawaiian/Pacific Islander race/ethnicity

Quarterly Progress Towards Goals

Q3 & Q4 vs. Labor Force Standard

EEO Category	White Male	White Fem	Black Male	Black Fem	Hisp Male	Hisp Fem	Asian Male	Asian Fem	AIAN Male	AIAN Fem	Ethn Unk	Total	Total Fem	Total Mnrt	Disab	Vets
Overall Totals of Progress Towards Goals																
Labor Force Standard Difference 12/31/2022	1,937	-1,237	16	-167	-464	-140	-1	-45	66	-12			-1,601	-707	-819	
Labor Force Standard Difference 09/30/2022	1,950	-1,241	6	-170	-458	-143	-3	-45	66	-12			-1,611	-724	-821	
Sum of 2022 Goals		252	93	156	146	95	34	42	14	14		846	559	594		
Sum of Progress Toward Goals		4	10	3	-6	3	2	0	0	0		16	10	17		

Sources: IHRPS B0178(f) Pop/Labor Force Census Compare by Federal Job Category; Job Placement Goals established using B0178(f) ; B0178 does not breakdown Two+ Races or Native Hawaiian/Pacific Islander race/ethnicity
 NCDOT Board of Transportation Meeting Minutes

The EEO Unit



- Tunya M. Smith, OCR Director
- Mark Whisenant, Interim EEO Manager
- Jacquay Bland, EEO Investigator
- Nicole Ingram, EEO Investigator
- Bentley Simms, EEO Program Specialist (HBCU Fellow)
- Elizabeth O. Wilson, EEO Program Specialist

Thank you!

RESOLUTION

NORTH CAROLINA DEPARTMENT OF TRANSPORTATION

RESOLUTION FOR NC CENTRAL UNIVERSITY 2022 HBCU FOOTBALL NATIONAL CHAMPIONS

WHEREAS, the North Carolina Central University men's football team was awarded the historically Black colleges and universities national championship on Dec. 17, 2022; and

WHEREAS, the N.C. Central Eagles beat the Jackson State University Tigers 41-34 in overtime; and

WHEREAS, N.C. Central finished the season 10-2 overall and 4-1 in the Mid-Eastern Athletic Conference; and

WHEREAS, N.C. Central's football team is the third team in the university's history to reach double-digit season victories; and

WHEREAS, this HBCU national championship marks the fourth for N.C. Central since 1954; and

WHEREAS, the N.C. Central Eagles also won the Mid-Eastern Athletic Conference in 2022; and

WHEREAS, this national championship victory meets the criteria to obtain championship road signs.

NOW, THEREFORE, BE IT RESOLVED:

That the North Carolina Board of Transportation congratulates and honors the *NC Central University 2022 HBCU Football National Champions*.

That appropriate signs will be erected at a suitable time.

Adopted this the 4th day of May 2023 by the
North Carolina Board of Transportation

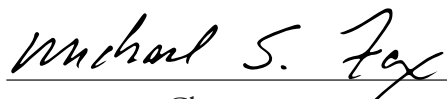

Chairman



Secretary of Transportation

RESOLUTION

NORTH CAROLINA DEPARTMENT OF TRANSPORTATION

RESOLUTION FOR COACH K HIGHWAY

WHEREAS, Michael William Krzyzewski was born Feb. 13, 1947, in Chicago, attended St. Helen Catholic School and Archbishop Weber High School; and

WHEREAS, Krzyzewski began his basketball career when he enrolled at the U.S. Military Academy; and

WHEREAS, Krzyzewski graduated from the U.S. Military Academy in 1969, served as an officer in the U.S. Army from 1969 to 1974, and was discharged from active duty in 1974 with the rank of captain; and

WHEREAS, Krzyzewski served as the head coach of the Duke University men's basketball team from 1980 to 2022, and earned a reputation as one of the greatest basketball coaches of all time; and

WHEREAS, Krzyzewski, who became affectionately known as 'Coach K,' has distinguished himself and brought honor to North Carolina for his distinguished military service and his success and leadership as the head coach of Duke University's men's basketball team for 42 consecutive years; and

WHEREAS, Krzyzewski, while the head men's basketball coach for Duke University, won 1,129 games and five national championships; and

WHEREAS, Krzyzewski amassed 1,202 career wins as a head coach in men's college basketball, the most victories by a head coach in NCAA history; and

WHEREAS, Coach K served with distinction on over 21 different USA Basketball coaching staffs, helping the teams win more than 95% of their games; he also served as the head coach for the U.S. Olympic men's basketball team, becoming the only Olympic head coach to ever win three consecutive gold medals in the sport; and

WHEREAS, he has served as an executive-in-residence at Duke University's Fuqua School of Business since 2001 and helped found the Coach K Center on Leadership and Ethics, directly influencing the leadership development of more than 6,500 Master of Business Administration students and executives since 2004; and

WHEREAS, Coach K is committed to public service, locally and nationally, by serving on boards for the Duke University Children's Hospital, The V Foundation for Cancer Research, the National Association of Basketball Coaches Foundation and the CEO Roundtable on Cancer; and

WHEREAS, Coach K has further invested in the well-being of the Durham community through the founding and ongoing support of the Emily K Center, which now serves more than 2,000 students of various grade levels each year; and

WHEREAS, Coach K's motivating, transformative and powerful leadership inspired generations of athletes across the world, and his legacy and impact at Duke University will be recognized long after his retirement; and

WHEREAS, that in appreciation of his distinguished service to the people of North Carolina and Durham, the Durham City Council and the Durham County Board of Commissioners request that the N.C. Board of Transportation honorarily designate a portion of N.C. 751 in Krzyzewski's honor.

NOW, THEREFORE, BE IT RESOLVED:

That the North Carolina Board of Transportation honorarily designates N.C. 751/Cameron Boulevard from Kerley Road to Duke University Road in Durham as the *Coach K Highway*.

That appropriate signs will be erected at a suitable time.

Adopted this the 4th day of May 2023 by the
North Carolina Board of Transportation.

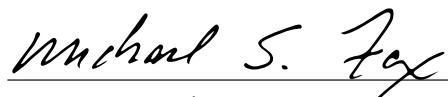

Chairman



Secretary of Transportation

RESOLUTION

NORTH CAROLINA DEPARTMENT OF TRANSPORTATION

RESOLUTION FOR OFFICER RYAN A HAYWORTH BRIDGE

WHEREAS, Ryan A. Hayworth was born March 17, 1998, in Cumberland County and was a lifelong North Carolinian; and

WHEREAS, Hayworth volunteered for many service activities while a member of Faith Baptist Church in Knightdale, where he led church youth groups and taught youth soccer camps; and

WHEREAS, Hayworth worked in homeless shelters and soup kitchens, cleaned up yards and did maintenance work for the elderly and those in need; and

WHEREAS, Hayworth graduated from East Wake Academy, joined the Army National Guard in 2016 and was serving as a specialist at the time of his passing; and

WHEREAS, Hayworth served in Kuwait during Operation Enduring Freedom and was awarded multiple medals; and

WHEREAS, Hayworth began his career with the Knightdale Police Department in July 2021 after graduating from the Basic Law Enforcement Training Academy at Wake Technical Community College; and

WHEREAS, Hayworth was killed in the line of duty by an impaired driver while serving as a Knightdale Police Officer on Oct. 17, 2021; and

WHEREAS, the Town of Knightdale and Wake County support naming a bridge in honor of Officer Hayworth.

NOW, THEREFORE, BE IT RESOLVED:

That the North Carolina Board of Transportation names the bridge on Knightdale Boulevard (U.S. 64 Business) over Interstate 540 the *Officer Ryan A Hayworth Bridge*.

That appropriate signs will be erected at a suitable time.

Adopted this the 4th day of May 2023 by the
North Carolina Board of Transportation

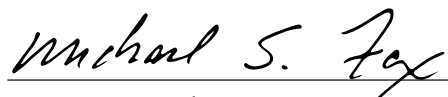

Chairman



Secretary of Transportation

RESOLUTION

NORTH CAROLINA DEPARTMENT OF TRANSPORTATION

RESOLUTION FOR REVEREND THOMAS L WALKER BRIDGE

WHEREAS, Thomas Lorenzo Walker was born in Rocky Mount, N.C., and grew up in Edgecombe County; and

WHEREAS, Walker graduated from G.W. Carver High School in 1966 and continued his education at Shaw University in Raleigh, where he earned a Bachelor of Theology from Shaw University Divinity School; and

WHEREAS, Walker, after graduating from Shaw University, returned to Rocky Mount to establish himself as a productive citizen who would give back to his community; and

WHEREAS, Walker became the pastor of The Ebenezer Missionary Baptist Church in Rocky Mount, N.C., in 1970; and

WHEREAS, Walker led Ebenezer as the church expanded by erecting a 1,000-seat, community-based facility near the heart of the city; and

WHEREAS, Walker was one of the first African-Americans elected to the Edgecombe County Board of Commissioners, a body he served for three terms; and

WHEREAS, Walker later served as the field representative for Congresswoman Eva Clayton and he founded the Edgecombe Nash Political Caucus, which focused on voter registration; and

WHEREAS, Walker served as president of the Greater Rocky Mount Ministers Council; and

WHEREAS, Walker was inducted into the Twin Counties Hall of Fame in 2010; and

WHEREAS, Walker has received multiple awards, including the Order of the Long Leaf Pine from Governor James B. Hunt in 1981; and

WHEREAS, Walker celebrated his 52nd pastoral anniversary of The Ebenezer Missionary Baptist Church in November 2022; and

WHEREAS, that the Rocky Mount City Council request that the State Board of Transportation name a bridge in honor of Reverend Thomas L. Walker.

NOW, THEREFORE, BE IT RESOLVED:

That the North Carolina Board of Transportation names the bridge on N.C. 97 overpassing the railroad tracks in Rocky Mount N.C., the *Reverend Thomas L Walker Bridge*.

That appropriate signs will be erected at a suitable time.

Adopted this the 4th day of May 2023 by the
North Carolina Board of Transportation

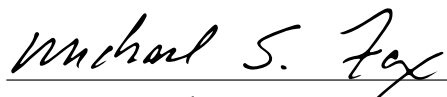

Chairman



Secretary of Transportation