

BIOLOGICAL ASSESSMENT

AN ASSESSMENT OF POTENTIAL EFFECTS TO ATLANTIC STURGEON AND CRITICAL HABITAT

For



Complete 540 – Triangle Expressway Southeast Extension Wake, Johnston, & Harnett Counties

STIP Project Nos. R-2721, R-2828, and R-2829
State Project Nos. 6.401078, 6.401079, and 6.401080
Federal Aid Project Nos. STP-0540(19), STP-0540(20), and STP-0540(21)
WBS Nos. 37673.1.TA2, 35516.1.TA2, and 35517.1.TA1

Prepared for:
Federal Highway Administration & North Carolina Department of Transportation



Prepared by:
Three Oaks Engineering, Inc.



January 2018

Table of Contents

1.0	INTRODUCTION.....	1
1.1	<i>Statutory Authority of Action.....</i>	1
1.2	<i>Summary of Consultation History.....</i>	1
2.0	PROJECT AND ACTION AREA DESCRIPTION.....	2
2.1	<i>Project Description.....</i>	2
2.2	<i>Description of Action Area.....</i>	2
2.3	<i>Federally Listed Species: Wake, Johnston, and Harnett Counties, NC.....</i>	2
2.3.1	<i>Neuse River Basin Portion of Action Area with Regards to Atlantic Sturgeon and Critical Habitat.....</i>	4
2.3.2	<i>Cape Fear River Basin Portion of Action Area with Regards to Atlantic Sturgeon and Critical Habitat.....</i>	4
2.4	<i>Habitat Conservation Plans In Action Area.....</i>	4
2.5	<i>Potential Effects of the Action.....</i>	4
2.6	<i>Conservation Measures.....</i>	6
2.7	<i>Other Consultations in Action Area.....</i>	6
3.0	ENVIRONMENTAL BASELINE FOR ATLANTIC STURGEON.....	6
3.1	<i>Watershed Conditions Baseline.....</i>	6
3.1.1	<i>Best Usage Classification.....</i>	7
3.1.2	<i>Impaired 303(d) Listing.....</i>	8
3.1.3	<i>Point Source Pollution.....</i>	9
3.1.4	<i>Non-point Source Pollution.....</i>	11
3.1.5	<i>Ecological Significance.....</i>	12
3.2	<i>Atlantic Sturgeon (Acipenser oxyrinchus oxyrinchus) Species Baseline.....</i>	13
3.2.1	<i>Species Characteristics.....</i>	13
3.2.2	<i>Distribution and Habitat Requirements.....</i>	14
3.2.3	<i>Summary of Atlantic Sturgeon within Action Area.....</i>	15
3.2.4	<i>General Threats to Atlantic Sturgeon.....</i>	15
3.2.4.1	Dams.....	16
3.2.4.2	Dredging.....	16
3.2.4.3	Water Quality.....	17
3.2.4.4	Water Quantity.....	18
3.2.4.5	Climate Change.....	19
3.2.4.6	Vessel Strikes.....	19
3.2.4.7	Bycatch Mortality.....	20
3.2.5	<i>Potential Effects of Roadway Projects on Atlantic Sturgeon.....</i>	21
3.2.5.1	Physical Effects.....	21
3.2.5.2	Water Quality Effects.....	22
3.2.5.3	Water Quantity Effects.....	22
3.2.6	<i>Designated Critical Habitat.....</i>	22
3.2.6.1	Physical Conditions of Critical Habitat in Project Footprint.....	23

4.0	EFFECTS OF PROPOSED ACTION ON ATLANTIC STURGEON AND CRITICAL HABITAT	24
4.1	<i>Construction Effects Evaluated</i>	24
4.1.1	<i>Stream Fill (Substrate (Habitat) Disturbance/Loss)</i>	25
4.1.2	<i>Noise Effects.....</i>	25
4.1.3	<i>Erosion/Sedimentation from Construction</i>	25
4.1.4	<i>Alteration of Flows/Channel Stability</i>	25
4.1.5	<i>Effects Associated with Borrow/Fill, Staging and Storage.....</i>	26
4.1.6	<i>Effects Associated with Geotechnical Drilling</i>	26
4.2	<i>Operational Effects Evaluated</i>	26
4.2.1	<i>Alteration of Flows/Channel Stability</i>	26
4.2.2	<i>Roadway Runoff.....</i>	27
4.2.3	<i>Toxic Spills.....</i>	28
4.3	<i>Induced Land Development Effects Evaluated</i>	28
4.3.1	<i>Induced Roadway Runoff Effects</i>	30
4.4	<i>Conclusions of Effects – Atlantic Sturgeon & Critical Habitat</i>	32
4.4.1	<i>Construction Effects.....</i>	32
4.4.1.1	<i>Stream Fill (Substrate (Habitat) Disturbance/Loss)</i>	32
4.4.1.2	<i>Noise Effects</i>	32
4.4.1.3	<i>Erosion/Sedimentation from Construction.....</i>	33
4.4.1.4	<i>Alteration of Flows/Channel Stability.....</i>	33
4.4.1.5	<i>Effects Associated with Borrow/Fill, Staging, and Storage.....</i>	33
4.4.1.6	<i>Effects Associated with Geotechnical Drilling</i>	34
4.4.2	<i>Operational Effects</i>	34
4.4.2.1	<i>Alteration of Flow/Channel Stability</i>	34
4.4.2.2	<i>Roadway Runoff</i>	35
4.4.2.3	<i>Toxic Spills</i>	35
4.4.3	<i>Induced Land Development Effects</i>	36
4.4.4	<i>Conservation Measures to Avoid/Minimize Effects to Atlantic Sturgeon and Critical Habitat.....</i>	37
4.4.4.1	<i>New Alignments/Roadways and Road Widening (Roadway Construction)</i>	38
4.4.4.2	<i>New Bridge, Bridge Replacement, and Bridge Widening; New and Replacement Piers.....</i>	39
4.4.4.3	<i>Installation, Maintenance, and Removal of Shoreline Stabilization</i>	39
4.5	<i>Summary of Conclusion of Effects-Atlantic Sturgeon & Critical Habitat</i>	40
4.5.1	<i>Atlantic Sturgeon</i>	40
4.5.2	<i>Critical Habitat.....</i>	40
4.5.3	<i>Determination of Effects</i>	42
5.0	LITERATURE CITED	43

Table of Tables

Table 1. USFWS Federally Listed Species.....	3
Table 2. FLUSA Streams within Five Pertinent Subbasins.....	8
Table 3. Five Pertinent Subbasins Impaired (Category 5) Streams 2014.....	9
Table 4. NPDES Individual Permitted Discharges in Select Neuse River Subbasins within FLUSA.....	10
Table 5. NPDES General Wastewater Permitted Sites within the Five Pertinent Subbasins.....	11
Table 6. Neuse River Basin Portion of FLUSA: Land Cover.....	11
Table 7. Natural Heritage Natural Areas within the Five Pertinent subbasins of the FLUSA (NCNHP 2017).....	13
Table 8. Water Quality Parameters from Build to No-Build Within Five Pertinent Subbasins ...	30

Appendix A. Figures

- Figure 1. Future Land Use Study Area (FLUSA) / Action Area and Preferred Alternative
- Figure 2. FLUSA/Action Area and Atlantic Sturgeon Critical Habitat Units
- Figure 3. Neuse River Subbasins
- Figure 4. Pertinent FLUSA Subbasins
- Figure 5. North Carolina Department of Environmental Quality 303(d) Impaired Streams
- Figure 6. National Pollutant Discharge Elimination System Discharge Permits
- Figure 7. Natural Heritage Natural Areas (NHNAs)
- Figure 8. Project Crossing of Neuse River
- Figure 9. Conceptual Layout for Bridge over Neuse River
- Figure 10. Conceptual Typical for Bridge of Neuse River
- Figure 11. Project Crossing of Neuse River in Relation to Auburn -Knightdale Road
Bridge

Appendix B. Habitat Characterization

Appendix C. Draft Programmatic Biological Evaluation (NLAA) on the Effects of

Transportation Activities and Project Undertaken in North Carolina, South Carolina, and Georgia

Appendix D. NCDOT Streambank Reforestation Guidelines

Glossary of Endangered Species Act Definitions:

Action Area - The geographic area encompassing all the physical, chemical, & biological changes that will occur directly or indirectly from the proposed action. Action area is typically larger than the footprint of the project and its direct impacts.

Cumulative effects - For purposes of consultation under the Endangered Species Act, the effects of future state or private activities not involving Federal activities that are reasonably certain to occur within the action area of an action subject to consultation. Cumulative effects are defined differently for purposes of the National Environmental Policy Act (NEPA). Under the NEPA definition, cumulative effects are the incremental environmental impact or effect of the proposed action, together with impacts of past, present, and reasonably foreseeable future actions, regardless of what agency (Federal or non-Federal) or person undertakes such other actions. Cumulative effects can result from individually minor but collectively significant actions taking place over a period of time (40 CFR 1508.7).

Direct effects - Effects that are caused by or will result from, and occur contemporaneous with, the proposed action.

Discountable – extremely unlikely to occur.

Indirect effects - An effect caused by a proposed action that takes place later in time than the action, but is still reasonably certain to occur.

Insignificant - Responses that are incapable of being detected, measured, or evaluated. This analysis relates to the amount or extent of the impact. If the impact will likely be negative but the consequences are so minute that a person could not measure or detect such responses, then it is appropriate to conclude insignificant effects.

Interdependent action- An action that has no independent utility apart from the proposed action that is subject to consultation.

Interrelated action - An action that is part of a larger action, and that depends on the larger action for its justification.

1.0 INTRODUCTION

The North Carolina Department of Transportation (NCDOT), in cooperation with the Federal Highway Administration (FHWA), proposes transportation improvements to NC 540, a project known as the “Complete 540 – Triangle Expressway Southeast Extension” in Wake and Johnston Counties, North Carolina (Figure 1). The proposed roadway is a controlled-access toll road, approximately 27 miles in length.

The purpose of this Biological Assessment (BA) is to evaluate the potential effects of the Complete 540 project on the federally listed Atlantic Sturgeon (*Acipenser oxyrinchus oxyrinchus*) and designated critical habitat in accordance with Section 7 of the Endangered Species Act (ESA) (16 U.S.C. 1536 (c)). Section 7(a) (2) of the ESA (16 USC 1531-1544 and Section 1536) requires that each Federal agency shall, in consultation with the U.S. Fish & Wildlife Service (USFWS) and National Marine Fisheries Service (NMFS), ensure that any action authorized, funded, or carried out by such agency, is not likely to jeopardize the continued existence of an endangered or threatened species, or result in the destruction or adverse modification of critical habitat. Since the proposed project includes both funding by FHWA and approval by the U.S. Army Corps of Engineers (USACE) pursuant to the Clean Water Act (CWA), the project is subject to consultation under Section 7 of the ESA. This BA is provided to satisfy the action agencies’ (FHWA and USACE’s) obligations under Section 7 of the ESA of 1973. FHWA is the lead federal agency for the National Environmental Protection Act (NEPA) and the ESA. FHWA and NCDOT are evaluating the project under NEPA, as amended (42 U.S.C. 4321, et seq.).

1.1 Statutory Authority of Action

The proposed project is included in the NCDOT’s *2016-2025 State Transportation Improvement Project* (STIP), project numbers R-2721 (NC 55 to US 401), R-2828 (US 401 to I-40), and R-2829 (I-40 to US/64/US 264 Bypass (I-495)). NCDOT derives their statutory authority via North Carolina General Statutes (NCGC) 143B-345 and 346 and FHWA derives their statutory authority via 49 US Code (USC) 104.

1.2 Summary of Consultation History

There is not a Complete 540 project consultation history for Atlantic Sturgeon and critical habitat. Critical habitat was designated by NMFS in August 2017, which was in the latter stages of the NEPA process for this project. Consultation history for other federally listed species is provided in a separate “Biological Assessment – An Assessment of Potential Effects to Federally Listed Species for Complete 540 – Triangle Expressway Southeast Extension” submitted to the USFWS December 6, 2017.

In September 2013, NCDOT published the Draft Alternatives Development and Analysis Report for the Complete 540 project, including a list of recommended Detailed Study Alternatives. NCDOT decided to study all recommended alternatives in detail in the Draft Environmental Impact Statement (DEIS), which was completed in October 2015. The preferred alternative was selected in April 2016 (Figure 1), and the Final Environmental Impact Statement (FEIS) was signed in December 2017.

A Qualitative Indirect and Cumulative Effects (ICE) study was prepared by Lochner and finalized in December 2014. A Quantitative ICE analysis was prepared for the FEIS (Baker Engineering 2017a-d). The first two parts of the study (Baker Engineering 2017a, Baker Engineering 2017b) were used to prepare the Memorandum on Water Quality Modeling Methodology and Results (Baker Engineering 2017c), and ICE Memorandum (Baker Engineering 2017d).

2.0 PROJECT AND ACTION AREA DESCRIPTION

2.1 Project Description

The Complete 540 project is proposed to be a controlled-access toll road extending the existing Triangle Expressway from NC 55 Bypass in Apex to the US 64/US 264 Bypass (I-495 or future I-87) in Knightdale, a distance of approximately 27 miles (Figure 1). The project will total approximately 1,240 acres within the proposed right of way (ROW). The proposed action will improve mobility, reduce forecast traffic congestion on the existing roadway network, and improve system linkage within the project study area.

2.2 Description of Action Area

The Action Area, as defined in 50 CFR 402.02, includes all areas to be affected directly or indirectly by a federal action and not merely the immediate area involved in the action, which for this project includes the land area within the Future Land Use Study Area (FLUSA) as defined in the Draft Environmental Impact Statement (DEIS). Portions of Wake, Johnston, and Harnett Counties, North Carolina are located within the Action Area (Figure 2). The FLUSA extends southward from the project alignment into northern Harnett County, and encompasses most of southern Wake County and a large portion of northern Johnston County (H.W. Lochner 2014), totaling approximately 278,000 acres.

2.3 Federally Listed Species: Wake, Johnston, and Harnett Counties, NC

During the development stages of this project, the USFWS county list of federally listed species was consulted for the three action area counties. The federally listed species shown in Table 1 were addressed in the “Biological Assessment – An Assessment of Potential Effects to Federally Listed Species for Complete 540 – Triangle Expressway Southeast Extension”:

Table 1. USFWS Federally Listed Species

Scientific Name	Common Name	Status
<i>Alasmidonta heterodon</i>	Dwarf Wedgemussel	E
<i>Elliptio lanceolate</i>	Yellow Lance	Proposed
<i>Fusconaia masoni</i>	Atlantic Pigtoe	Petitioned
<i>Haliaeetus leucocephalus</i>	Bald Eagle	BGPA
<i>Lasmigona subviridis</i>	Green Floater	Petitioned
<i>Lysimachia asperulaefolia</i>	Rough-leaved Loosestrife	E
<i>Necturus lewisi</i>	Neuse River Waterdog	Petitioned
<i>Notropis mekistocholas</i>	Cape Fear Shiner	E
<i>Noturus furiosus</i>	Carolina Madtom	Petitioned
<i>Parvaspina steinstansana</i>	Tar River Spinymussel	E
<i>Picoides borealis</i>	Red-cockaded Woodpecker	E
<i>Rhus michauxii</i>	Michaux's Sumac	E

Notes: BGPA – Bald and Golden Eagle Protection Act, T – Threatened, E – Endangered

On April 6, 2012, the NMFS listed the Atlantic Sturgeon as Endangered. This species is under the purview of NMFS and is not on the USFWS species list for Wake, Johnston, or Harnett County, as it has never been reported from those counties. On August 17, 2017, NMFS designated critical habitat for the Atlantic Sturgeon in the Neuse River (Carolina Unit 3), which includes a portion of the river in Wake County, and all the river in Johnston County. The Federal Register [50 CFR Part 226, Vol. 8, No. 158, August 17, 2017, (NMFS 2017a)] describes the critical habitat unit as follows:

“Carolina Unit 3, Neuse Unit. Neuse River in Carteret, Craven, Duplin, Johnston, Lenoir, Pamlico, Pitt, Wake, and Wayne Counties in North Carolina.

Carolina Unit 3 includes the Neuse River main stem from the Milburnie Dam downstream to river kilometer (RKM) 0 (Figure 2). The Neuse River, one of two major tributaries to Pamlico Sound, is dammed. It is likely that Atlantic Sturgeon historically utilized habitat in the Neuse River up to the falls at RKM 378 where a dam (Falls Dam) is now located, although this site is above the fall line (Atlantic Sturgeon Status Review Team [ASSRT] 2007). Spawning migration may be impeded to historic habitat above the Milburnie Dam (RKM 349).”¹

While the entire project alignment and the majority of the FLUSA component of the Action Area occurs within the Neuse River Basin, the southeastern component of the FLUSA drains to the Cape Fear River Basin. Critical Habitat for the Atlantic Sturgeon was also designated on August

¹ In November 2017, the Milburnie Dam was removed as part of a stream mitigation bank; thus, there is no longer a physical barrier to the falls at RKM 378

17, 2017 in the Cape Fear River (Carolina Unit 4); however, no part of this unit occurs within the Action Area (see Section 2.3.2)

2.3.1 Neuse River Basin Portion of Action Area with Regards to Atlantic Sturgeon and Critical Habitat

The portion of the Carolina Unit 3 between Neuse RKM 346 and 321 are contained within the Action Area, and the project involves a new crossing of the river at RKM 338. Potential project related effects to this portion of critical habitat and the Atlantic Sturgeon were evaluated in this BA (Section 4.0).

2.3.2 Cape Fear River Basin Portion of Action Area with Regards to Atlantic Sturgeon and Critical Habitat

The project alignment is not in the Cape Fear Basin. Based on the Complete 540 ICE Report (Baker Engineering 2017a-d), the only potential water quality and habitat effects within the Cape Fear River Basin would be induced land development. In the entire Cape Fear portion of the Action Area, the anticipated change in land use from Build to No-Build is less than 1%. The only modeled change that exceeded 1% is in Hector Creek, which had a high-end model result of 2% increase in total phosphorous from No-Build to Build. On August 17, 2017, NMFS designated critical habitat for the Atlantic Sturgeon in the Cape Fear River from the river mouth near Southport up to Lock and Dam # 2 near Elizabethtown, which is a recognized barrier to Atlantic Sturgeon migration, and in the Northeast Cape Fear River from the Cape Fear River upstream to the town of Mount Olive (Carolina Unit 4). The portion of the Action Area within the Cape Fear River Basin is greater than 80 river miles upstream of Lock and Dam # 2, and there is another barrier Lock and Dam # 3 (William O. Huske Lock and Dam) located between the Action Area and the critical habitat unit. Given the distance between the Cape Fear River Basin portion of the Action Area to Critical Habitat, the presence of physical barriers (Lock and Dam # 2 and # 3) in between, and the low amount of induced effects to the Cape Fear River Basin, it was determined that the project action would have no effect on the critical habitat Carolina Unit 4; thus, further consideration of Carolina Unit 4 in the BA was not warranted.

2.4 *Habitat Conservation Plans In Action Area*

There have been no Habitat Conservation Plans developed for Atlantic Sturgeon within the Action Area.

2.5 *Potential Effects of the Action*

Effects of the action refer to the direct and indirect effects on the species and/or critical habitat, together with the effects of other activities that are interrelated or interdependent with the action that will alter the environmental baseline. Direct effects are caused by the proposed action and

generally occur at the same time and place as the project. Indirect effects are those that are caused by the proposed action and are later in time, but still are reasonably certain to occur [50 CFR 402.02]. These types of effects can include natural responses to the proposed action's direct effects, or can include human induced effects associated with the proposed action [50 CFR 402.02].

Interrelated actions are defined as actions that are part of a larger action and depend on the larger action for their justification. Interdependent actions are those that have no independent utility apart from the action under consideration. Interrelated/interdependent action areas include project-associated utility relocations, as well as construction borrow pits, haul roads, staging areas, and human development and patterns induced by the action.

Preliminary roadway designs for the Preferred Alternative are in progress at the time of this BA submittal, therefore, the proposed roadway used for planning purposes consists of a six-travel lane facility with 70-foot median. For areas where existing roads would cross over or under the highway, various existing two and four-lane roads (e.g., Sunset Lake Road and Holly Springs Road) would be widened to be consistent with the adopted Metropolitan Transportation Plan. The areas of construction effects will encompass:

- The Complete 540 roadway footprint, including improvements along crossing roads
- Adjacent areas affected for permanent fixtures (noise walls, ROW fences, etc.)
- Associated utility relocations (temporary as well as permanent)
- Haul/access roads
- Staging areas
- Borrow sites
- Other ground disturbing activities directly associated with the project.

Cumulative effects are those of future state or private activities, not involving federal activities, which are reasonably certain to occur within the Action Area of the proposed federal action. In addition to highway improvements, other infrastructure projects such as water and sewer service have the potential to stimulate land development and directly or indirectly result in effects within the Action Area. However, these other types of infrastructure will likely require some type of federal authorization, such as a Clean Water Act (CWA) 404 permit, and would therefore, have their own ESA Section 7 consultation and not be considered a cumulative effect under ESA for this action. Thus, most anticipated cumulative effects are likely to be localized and small in scale, but when these effects are added to other effects, they may further affect the species in question.

2.6 Conservation Measures

Conservation measures are those measures that facilitate conservation of the species and offer some level of protection by avoiding, minimizing, or off-setting, project related effects.

Conservation measures are included as part of the Action. These measures are discussed in Section 4.4.4 of this report.

2.7 Other Consultations in Action Area

On November 2, 2017 NCDOT submitted a Section 7 Coordination for Atlantic Sturgeon letter to Rachael Sweeney of the NMFS for TIP No. R-3825B, the proposed widening of an approximately 4.5-mile section of NC 42, that involves a replacement of Bridge 75 over the Neuse River in Johnston County. This project occurs within the eastern boundary of the FLUSA component of the Action Area. This letter provided a completed NMFS Section 7 Checklist with supporting project information along with a biological conclusion for the Atlantic Sturgeon of “May affect, not likely to adversely affect”. We are not aware of any other consultations for Atlantic Sturgeon within the Action Area.

3.0 ENVIRONMENTAL BASELINE FOR ATLANTIC STURGEON

The project alignment and the majority of the FLUSA component of the Action Area occurs within the Neuse River Basin and eventually drains into the Carolina Unit 3. During the ICE analysis, the area of effects associated with the action were viewed in the context of subbasins. There are 18 Neuse River subbasins (Figure 3) that occur in part, or entirely within the FLUSA. Based on anticipated project effects within the respective subbasins, as well as their proximity to, or the distance from, the downstream extent of the subbasin to critical habitat, the following five pertinent subbasins are evaluated in more detail in this BA and are noted in Figure 4:

- Lower Middle Creek
- Reed Branch-Swift Creek
- Poplar Creek – Neuse River
- Walnut Creek
- Lower Crabtree Creek

3.1 Watershed Conditions Baseline

Critical habitat for Atlantic Sturgeon has been designated in the Neuse River within the Action Area. The current physical and chemical conditions of this portion of the Neuse River are primary factors that influence the population status of this species. The Upper Neuse River Basin (US Geological Survey hydrologic unit 03020201) covers an area of approximately 540,000 acres in Person, Orange, Durham, Granville, Franklin, Wake, Johnston, Wilson and

Wayne Counties. The Upper Neuse River drains all of Raleigh, Hillsborough, Wake Forest, Garner, and portions of Durham, Cary, and several other municipalities. The headwaters of the Neuse River are the Eno, Flat, and Little Rivers in Person and Orange Counties, which flow southeast into Falls Lake in Durham and Granville Counties, a manmade reservoir covering more than 12,000 acres. Following in the southeasterly flow, the next major tributaries to the Neuse River are Crabtree Creek and Walnut Creek in Wake County and Swift Creek, Middle Creek, Black Creek, and Mill Creek in Johnston County. The Little River flows into the Neuse River in Wayne County. Downstream, the Neuse River flows through the Middle Neuse River Basin and continues toward Pamlico Sound and the Atlantic Ocean. Baseline conditions of the five pertinent subbasins are discussed below.

3.1.1 Best Usage Classification

The North Carolina Department of Environmental Quality (NCDEQ) assigns a best usage classification to all waters of North Carolina. These classifications, which are the responsibility of the Division of Water Resources (NCDWR), provide a level of water quality protection to ensure that the designated usage of that water body is maintained. The minimum designation of Class C waters is defined as waters that are suitable for aquatic life propagation and survival, fishing, wildlife, secondary recreation and agriculture. Class C imposes a minimum standard of protection for all waters of North Carolina; they are protected for secondary recreation, fishing, wildlife, fish and aquatic life propagation and survival, agriculture, and other uses suitable for Class C. Class B waters provide the same protection as Class C waters, plus primary recreation. Primary recreation is the use of waters for swimming or other activities involving contact with the water. Water Supply (WS) waters are protected for Class C uses and additionally are used as a source of drinking water or other uses of consumption. WS classifications are further categorized with a suffix of -I to -V, with -I being in undeveloped areas in public ownership and having a High Quality Waters supplemental classification and -V having the least amount of protection and often used by industry. A classification of WS-III, which is found in streams within the Action Area, have fewer restrictions than WS-I and WS-II streams and are found in low to moderately developed areas. Nutrient Sensitive Waters (NSW) is a supplemental classification intended for waters needing additional nutrient management due to being subject to excessive growth of microscopic or macroscopic vegetation. The entire Neuse River Basin is classified as NSW.

Table 2 lists the named streams within the five pertinent subbasins and their Hydrologic Unit Code (HUC), their Usage Classification, and NCDWR Index number (#). Unnamed tributaries carry the classification of the receiving water body. Figure 4 shows the streams in the five pertinent subbasins of the FLUSA.

Table 2. FLUSA Streams within Five Pertinent Subbasins

Stream Name	Usage Classification	DWR Index #
Lower Middle Creek (HUC# 030202010903)		
Beaverdam Branch	C; NSW	27-43-15-13
Buffalo Branch	C; NSW	27-43-15-11
Cow Branch	C; NSW	27-43-15-14
Middle Creek	C; NSW	27-43-15-(4)
Mill Branch	C; NSW	27-43-15-12
Shop Branch	C; NSW	27-43-15-15
Steep Hill Branch	C; NSW	27-43-15-16
Reed Branch-Swift Creek (HUC# 03020201107)		
Cooper Branch	C; NSW	27-43-12
Reedy Branch (Little Branch)	C; NSW	27-43-14
Swift Creek	C; NSW	27-43-(8)
Poplar Creek-Neuse River (HUC# 03020201103)		
Beddingfield Creek	C; NSW	27-37
Neuse River	C; NSW	27-(20.7)
Neuse River	WS-V; NSW	27-(36)
Neuse River	WS-V; NSW	27-(38.5)
Neuse River	WS-V; NSW	27-(41.7)
Poplar Creek	C, NSW	27-35
Walnut Creek (HUC# 03020201101)		
Walnut Creek	C, NSW	27-34-(4)
Poplar Branch	C, NSW	27-34-11-1
Big Branch	C, NSW	27-34-11
Little Arm Branch	C; NSW	27-34-11-2
Lower Crabtree Creek (HUC# 030202010804)		
Carolina Lake	C; NSW	27-33-22
Crabtree Creek	C, NSW	27-33-(10)

3.1.2 Impaired 303(d) Listing

As mandated in Section 303(d) of the CWA by the US Environmental Protection Agency (EPA), states, territories, and authorized tribes are required to develop lists of impaired waters, which are defined as water bodies that do not meet water quality standards that states, territories, and authorized tribes have set for them, even after point sources of pollution have installed the minimum required levels of pollution control technology. These water quality standards include designated uses, numeric and narrative criteria, and anti-degradation requirements as defined in 40 CFR 131. Failures to meet standards may be due to an individual pollutant, multiple pollutants, or unknown causes of impairment, originating from point and non-point sources and/or atmospheric deposition. The law requires that these jurisdictions establish priority rankings for waters on the lists and develop Total Maximum Daily Load (TMDLs) limits of identified pollutants for these waters.

The 303(d) Category 5 streams, which require a TMDL or TMDL alternative, in the five pertinent subbasins are listed in Table 3 along with details of the impairments. They are also shown in Figure 5. As of the writing of this report, the 2016 303(d) list has not been finalized, though a draft was submitted to the EPA. The draft 2016 303(d) list (NCDEQ 2017a), submitted by NCDEQ, proposes that the Neuse River AU [27-(22.5)c] no longer be listed for copper, and the Neuse River AU [27-(36)] no longer be listed as impaired.

Table 3. Five Pertinent Subbasins Impaired (Category 5) Streams 2014.

Stream	AU Number	Length/Area	Reason for Rating	Parameter (Year)
Lower Middle Creek (HUC# 030202010903)				
None				
Reed Branch-Swift Creek (HUC# 03020201107)				
None				
Poplar Creek-Neuse River (HUC# 030202011103)				
Neuse River	27-(22.5)c	3.9 FW Miles	Exceeding Criteria	Copper (2008)
Neuse River	27-(22.5)c	3.9 FW Miles	Exceeding Criteria	PCB Fish Tissue Advisory (2010)
Beddingfield Creek	27-37	3.7 FW Miles	Fair Bioclassification	Ecological/Bio Int, Benthos (2014)
Neuse River	27-(36)	4.3 FW Miles	Exceeding Criteria	Copper (2008)
Neuse River	27-(36)	4.3 FW Miles	Exceeding Criteria	Zinc (2008)
Neuse River	27-(38.5)	9.7 FW Miles	Exceeding Criteria	Copper (2012)
Walnut Creek (HUC# 030202011101)				
Walnut Creek	27-34-(4)b	3.7 FW Miles	Exceeding Criteria	Copper (2008)
Walnut Creek	27-34-(4)b	3.7 FW Miles	Exceeding Criteria	PCB Fish Tissue Advisory (2012)
Lower Crabtree Creek (HUC# 030202010804)				
Crabtree Creek	27-33-(10)c	2.75 FW Miles	Exceeding Criteria	PCB Fish Tissue Advisory (2012)

Notes: FW – Freshwater Miles

3.1.3 Point Source Pollution

Point source discharge is defined as discharge that enters surface waters through a pipe, ditch, or other well-defined point of discharge. This includes municipal (city and county) and industrial wastewater treatment facilities, small domestic discharging treatment systems (schools, commercial offices, subdivisions and individual residents), and stormwater systems from large urban areas and industrial sites. The primary substances and compounds associated with point source discharge include nutrients, oxygen demanding wastes, and toxic substances such as chlorine, ammonia, and metals.

Under Section 301 of the CWA, discharge of pollutants into surface waters is prohibited without a permit by the EPA. Section 402 of the CWA establishes the National Pollutant Discharge Elimination System (NPDES) permitting program, which delegates permitting authority to qualifying states. In North Carolina, NCDWR is responsible for permitting and enforcement of

the NPDES program. Point source dischargers located throughout North Carolina are permitted through the NPDES program. All dischargers are required to register for a permit. NPDES dischargers are divided into two categories: individual and general. General permits are issued for specific activities, including non-contact cooling water discharges, petroleum-based groundwater remediation, sand dredging, seafood packaging, and domestic discharges from single family residences. Individual permits are issued on a case-by-case basis for activities not covered under general permits. Individual permits are divided into two classes: major and minor. Major discharges are permitted to discharge one million gallons per day (MGD) or greater. Minor discharges are permitted to discharge less than 1 MGD. General permits, on the other hand, cover discharges with similar operations and types of discharges that are applicable state-wide. The requirements of a general permit are defined and known by the permittee. In general, an individual permit will take longer to be issued than a general permit (NCDEQ 2017b).

The NPDES Permitting Policy includes limits on various parameters, including, but not limited to chlorine (since October 2002), ammonia, fecal coliform, biological oxygen demand (BOD), dissolved oxygen (DO), flow, and temperature, for the existing facilities.

There are 8 individual permitted discharges and 4 general permitted discharges in the five pertinent subbasins (Tables 4 and 5), respectively, which are depicted in Figure 6.

Table 4. NPDES Individual Permitted Discharges in Select Neuse River Subbasins within FLUSA

Permit	Facility	Receiving Stream	Flow (GPD)	Owner
Lower Middle Creek (HUC# 030202010903)				
None				
Reed Branch-Swift Creek (HUC# 03020201107)				
None				
Poplar Creek-Neuse River (HUC# 030202011103)				
NC0038784	Neuse River Village WWTP	Neuse River	35,000	Aqua NC, Inc.
NC0040266	Knightdale Estates MHP WWTP	Neuse River	25,000	Knightdale Estate MHP LP
NC0056391	Cross Creek Mobile Estates	Neuse River	70,000	Aqua NC, Inc.
NC0065706	Cottonwood/Baywood WWTP	Poplar Creek	115,000	Crosby Utilities, Inc.
NC0051322	Ashley Hills WWTP	Poplar Creek	495,000	Carolina Water Service Inc. of NC
NC0062219	Kings Grant Subdivision WWTP	Poplar Creek	210,000	Carolina Water Service Inc. of NC
NC0029033	Neuse River Resource Recovery Facility	Neuse River	75,000,000	City of Raleigh Public Utilities Department
NC0064378	Willowbrook WWTP	Beddingfield Creek	60,000	Carolina Water Service Inc. of NC
Walnut Creek (HUC# 030202011101)				
None				
Lower Crabtree Creek (HUC# 030202010804)				
None				

WRF = Water Reclamation Facility, WTP = Water Treatment Plant, WWTP = Wastewater Treatment Plant

Table 5. NPDES General Wastewater Permitted Sites within the Five Pertinent Subbasins

<u>Permit</u>	<u>Facility</u>	<u>Receiving Stream</u>	<u>Permit Type</u>
Lower Middle Creek (HUC# 030202010903)			
NCG510527	Don Lee Gas and Grocery	UT to Middle Creek	Groundwater Remediation
Reed Branch-Swift Creek (HUC# 03020201107)			
None			
Poplar Creek-Neuse River (HUC# 030202011103)			
NCG550336	Single Family	Beddingfield Creek	Domestic
NCG550925	Single Family	Beddingfield Creek	Domestic
Walnut Creek (HUC# 030202011101)			
NCG550441	Single Family	Walnut Creek	Domestic
Lower Crabtree Creek (HUC# 030202010804)			
None			

3.1.4 Non-point Source Pollution

Non-point source (NPS) pollution refers to runoff that enters surface waters through stormwater or snowmelt. There are many types of land use activities that contribute to NPS pollution, including land development, construction activity, animal waste disposal, mining, agriculture, and forestry operations, as well as impervious surfaces such as roadways and parking lots. Various NPS management programs have been developed by several agencies to control specific types of NPS pollution (e.g. pesticide, urban, and construction related pollution). Each of these management plans develops Best Management Practices (BMPs) to control for a specific type of NPS pollution. For example, financial incentives to reduce agricultural NPS pollution are provided through North Carolina’s Agriculture Cost Share Program, administered by the North Carolina Department of Agriculture and Consumer Service’s Division of Soil and Water Conservation to protect water quality by installing BMPs on agricultural lands.

Land cover collectively for the 18 Neuse River subbasins of the FLUSA is described in Table 6. Deciduous forest makes up the greatest percent of land cover in this portion of the FLUSA, followed closely by developed open space (such as lawns, parks, and golf courses).

Table 6. Neuse River Basin Portion of FLUSA: Land Cover

Land Cover	Sum of Area (Acres)	Percent
Barren Land	1255.6	0.53
Cultivated Crops	22641.8	9.59
Deciduous Forest	42349.6	17.94
Developed, High Intensity	1296.8	0.55
Developed, Low Intensity	16301.3	6.91
Developed, Medium Intensity	5671.2	2.40
Developed, Open Space	38613.3	16.36
Emergent Herbaceous Wetlands	840.8	0.36
Evergreen Forest	25698.5	10.89
Hay/Pasture	25471.4	10.79

Table 6. Neuse River Basin Portion of FLUSA: Land Cover (continued)

Land Cover	Sum of Area (Acres)	Percent
Herbaceous	19795.4	8.39
Mixed Forest	12858.4	5.45
Open Water	2830.4	1.20
Shrub/Scrub	5680.6	2.41
Woody Wetlands	14751.6	6.25
Total	236056.7	100.00

Note: While the same National Land Cover Data raw data were used in the Memorandum on Land Use Scenario – Methodology and Results (Baker Engineering 2017a-d), the Memorandum further modified the data as required for use in various models. Therefore, this data in Table 6 and ICE Memo #2 Table 4 does not exactly match.

3.1.5 Ecological Significance

The North Carolina Natural Heritage Program (NCNHP) maintains a database of rare plant and animal species, as well as significant natural areas, for the state. The NCNHP compiles the North Carolina Department of Natural and Cultural Resources priority list of “Natural Heritage Areas” as required by the Nature Preserves Act (NCGS 113A-164 of Article 9). Natural areas (sites) are inventoried and evaluated on the basis of rare plant and animal species, rare or high quality natural communities, and geologic features occurring in the particular site. NCNHP has revised its process for establishing conservation priorities (NCDENR 2015) for the more than 2,400 Natural Heritage Natural Areas (NHNA) that have been identified through field investigations. Each NHNA receives two significance ratings, which measure different values and assign a rating from 1 (exceptional) to 5 (general):

1. Element Collective Value rates each NHNA based on the number and rarity of all the elements it contains.
2. Element Representational Value rates each NHNA on its importance in protecting the best occurrences of individual elements.

The following sites are the natural areas within the five pertinent subbasins of the FLUSA (Figure 7, Table 7).

Table 7. Natural Heritage Natural Areas within the Five Pertinent subbasins of the FLUSA (NCNHP 2017)

<u>Natural Heritage Natural Area</u>	<u>Representational Value</u>	<u>Collective Value</u>
Lower Middle Creek (HUC# 030202010903)		
NEU/Middle Creek Aquatic Habitat	N/A	C3 (High)
Middle Creek Amphibolite Slope	R5 (General)	C5 (General)
Middle Creek Floodplain Knolls	R5 (General)	C5 (General)
Reed Branch-Swift Creek (HUC# 03020201107)		
NEU/Swift Creek Aquatic Habitat	N/A	C3 (High)
Reedy Branch Floodplain	R3 (High)	C5 (General)
Poplar Creek-Neuse River (HUC# 03020201103)		
Neuse River (Clayton) Forests	R5 (General)	C4 (Moderate)
Walnut Creek (HUC# 03020201101)		
None		
Lower Crabtree Creek (HUC# 030202010804)		
None		

3.2 *Atlantic Sturgeon (Acipenser oxyrinchus oxyrinchus) Species Baseline*

Status: Endangered

Family: Acipenseridae

Listing: Carolina Distinct Population Segment (DPS) April 6, 2012

Critical Habitat: Designated August 17, 2017

3.2.1 *Species Characteristics*

The Atlantic Sturgeon can live up to 60 years, mature later in life (as compared to other similar species), and travel up rivers to spawn in freshwater and swim back downstream to marine environments (anadromous). Atlantic Sturgeon can reach approximately 14 feet (4.3 m) in length and can be up to 800 pounds (370 kg) (NMFS 2012). They are bluish-black or olive brown on their back and have paler sides and a white belly. Instead of scales, they have five major rows of dermal scutes, which are boney plates found on the head, sides, and the belly.

The appearance of the Atlantic Sturgeon is similar to that of the sympatric Shortnose Sturgeon (*Acipenser brevirostrum*), but Atlantic Sturgeon is generally larger, have a smaller mouth, have a different shaped snout, and different scute patterns. Atlantic Sturgeon have a pale, as opposed to dark lining of the body cavity lining and intestine, as well as scutes between the anal fin and mid-lateral scutes, which are lacking in the Shortnose Sturgeon (Rohde et al. 2009). The Atlantic Sturgeon has lighter colored scutes, which contrast with their darker body. The Atlantic Sturgeon has a shovel-shaped snout, which is generally longer, and is v-shaped; however, this is not a reliable distinguishing characteristic of Atlantic Sturgeon, as the snout of juvenile Shortnose Sturgeon may be long and pointed, but shortens with age (Rohde et al. 2009). The mouth of the Atlantic Sturgeon contains “large fleshy barbells that protrude from the underside of the snout, enabling foraging along the substrate for prey items such as mussels and crustaceans” (FHWA 2014).

There is generally faster growth and earlier age of maturation in more southern populations of Atlantic Sturgeon. For example, Atlantic Sturgeon mature in South Carolina rivers at 5-19 years of age, in the Hudson River at 11-21 years, and in the Saint Lawrence River at 22-34 years (ASSRT 2007).

Spawning adults swim upriver in late winter to spring, depending on the population; in the south, migration occurs between February and March, in the mid-Atlantic, migration occurs between April and May, and in Canada, migration occurs between May and June. A small spawning migration may also take place in the fall, again depending on the population (ASSRT 2007). Spawning occurs in flowing water between the salt wedge and fall line of large rivers. Spawning intervals, or the amount of time between spawning events for an individual fish, is estimated to be 1 to 5 years for males and 2 to 5 years for females. The number of eggs laid by a female Atlantic Sturgeon is dependent on age and body size and can be between 400,000 and 8 million eggs. On average, 50% of the Atlantic Sturgeon population reach maximum lifetime egg production at 29 years; by comparison, this is 3-10 times older than for other similar fish species (bony fish) (NMFS 2017a).

Atlantic Sturgeon eat benthic invertebrates, such as crustaceans, worms, mollusks, from when they are juveniles and through adulthood (NMFS 2017a and references contained within).

After spawning, males may stay in the river or lower estuary until the fall; females usually return to coastal waters within four to six weeks. Juveniles spend their first months to years in fresh or brackish waters and estuaries of their natal (birth) large rivers (Bain 1997, Holland and Yelverton 1973) and when they reach a size of about 30-36 inches (76-92 cm) they move into nearshore coastal waters. Tagging data suggest that juvenile Atlantic Sturgeon travel widely once they leave their natal (birth) rivers (NMFS 2017a).

3.2.2 *Distribution and Habitat Requirements*

Atlantic Sturgeon are found in rivers, estuaries, and near-shore marine environments of eastern North America and the Atlantic Ocean from Labrador, Canada to southeastern Florida, and west to the Mississippi River Delta (Rohde et al. 2009). The population from the west coast of Florida to the Mississippi Delta, the Gulf Sturgeon (*Acipenser oxyrinchus desotoi*), is a subspecies of the Atlantic Sturgeon (Wooley, 1985).

Spawning typically occurs in flowing water between the salt front of estuaries and below the fall line, or an upstream physical impediment such as a dam or large rapids (NMFS 2017a and references contained within). Spawning sites are well-oxygenated areas with flowing water ranging in temperature from 13 °C (55°F) to 26 °C (79°F), and hard bottom substrate such as cobble, hard clay, and bedrock (Vladykov and Greeley 1963, NMFS 2017a). The eggs of Atlantic Sturgeon are adhesive to the hard substrate of the river bottom. The newly hatched

larvae are demersal (Smith et al. 1980), having a close affinity to the river bottom. Benthic structure, such as a gravel matrix, or hard bottom is used as refugia during the migration of larvae to the juvenile rearing grounds. The salinity and DO requirements of juvenile rearing habitat can be variable and are summarized in NMFS 2017a.

3.2.3 Summary of Atlantic Sturgeon within Action Area

The Pamlico Sound (Tar and Neuse Rivers) Atlantic Sturgeon population is speculated to be small compared to other populations (Albemarle Sound, Cape Fear Estuary) in North Carolina (ASSRT 2007, Oakley 2003). There are no records of Atlantic Sturgeon within the Action Area, in either Wake, or Johnston Counties, with all records from the basin being further downriver. There is also no documented spawning activity in the Neuse River; however, juveniles are well documented in the Middle and Lower sections of the Neuse River (ASSRT 2007, Oakley 2003, Hoff 1980, Hassler 1974). Oakley (2003) and Hassler (1974) captured juveniles as far upriver as RKM 80. Given that juveniles remain in their natal rivers, it is a logical assumption that the individuals captured in the river, were spawned upstream. The NMFS used this life history attribute, along with the presence of suitable spawning habitat features and lack of physical barriers to justify designating critical habitat up to RKM 328 (Milburnie Dam).

In 1999, the Quaker Neck Dam on the Neuse River at RKM 225 was removed. The dam was a known impediment for spawning migrations of other anadromous species, American Shad (*Alosa sapidissima*) and Striped Bass (*Morone saxatilis*). Following removal of the Quaker Neck Dam, spawning runs of both species were documented up to the Milburnie Dam at RKM 328 (Bowman & Hightower 2001, Beasley & Hightower 2000). As footnoted in Section 2.2, the Milburnie Dam was removed in November 2017. One of the mitigation goals of the Milburnie Dam removal project (Restoration Systems 2016) is to restore spawning runs of anadromous species up to RKM 370 (Falls Dam), which is speculated to be the historic upstream barrier (ASSRT 2007) of Atlantic Sturgeon. The low population numbers and life history attributes of Atlantic Sturgeon (being long-lived, having late maturation, and not spawning every year), coupled with the relatively recent removal of the Quaker Neck dam (18 years), may be a factor in the absence of Atlantic Sturgeon records in the upper reaches of the river.

3.2.4 General Threats to Atlantic Sturgeon

According to the Shortnose Sturgeon recovery plan (NMFS 1998) and Atlantic Sturgeon status review (ASSRT 2007), projects that may adversely affect sturgeon include dredging, pollutant or thermal discharges, bridge construction/removal, dam construction, removal and relicensing, and power plant construction and operation.

Atlantic Sturgeon populations were reduced by over 90% by the late 1800s due to overharvesting for their meat and eggs. It became illegal to fish for Atlantic Sturgeon in 1998 in state waters,

and became illegal in remaining U.S. waters in 1999. Atlantic Sturgeon face continuing threats due to dams, dredging, poor water quality, and accidental bycatch. Atlantic Sturgeon populations in some rivers have rebounded; East Coast populations have remained low or been extirpated entirely. The DPSs listed as threatened and endangered under the ESA were identified because of the continued challenges facing these populations, namely limits on habitat (impoundments), bycatch, and ineffectiveness of existing regulations to reverse these threats (FHWS 2017), and are described in detail below. Much of the language in Sections 3.2.4.1 through 3.2.4.7 is taken directly from the Draft Programmatic Biological Evaluation (NMFS 2017b).

3.2.4.1 Dams

Dams for hydropower generation, flood control, and navigation adversely affect Atlantic Sturgeon by impeding access to spawning, developmental, and foraging habitat, modifying free-flowing rivers to reservoirs, physically damaging fish on upstream and downstream migrations, and altering water quality in the remaining downstream portions of spawning and nursery habitat (ASSRT 2007). Attempts to minimize the effects of dams using measures such as fish passage have not proven beneficial to Atlantic Sturgeon, as they do not regularly use existing fish passage devices, which are generally designed to pass pelagic fish (i.e., those living in the water column) rather than bottom-dwelling species, like sturgeon. Within the range occupied by the Carolina DPS, dams have restricted Atlantic Sturgeon spawning and juvenile developmental habitat by blocking over 60% of the historical sturgeon habitat upstream of the dams in the Cape Fear and Santee-Cooper River systems. Water quality (velocity, temperature, and dissolved oxygen (DO)) downstream of these dams, as well as on the Roanoke River, has been reduced, which modifies and restricts the extent of spawning and nursery habitat for the Carolina DPS.

With the removal of the Quaker Neck Dam at RKM 225 in 1999 and the Milburnie Dam at RKM 328 in November 2017, there are no longer any barriers to upstream migration on the Neuse River until the Falls Dam at RKM 370, which was built on natural falls (i.e., Falls of Neuse). This location is the suspected historic natural upstream limit of spawning habitat for this species in the river (ASSRT 2007).

3.2.4.2 Dredging

Riverine, nearshore, and offshore areas are often dredged to support commercial shipping and recreational boating, construction of infrastructure, and marine mining. Environmental effects of dredging include the direct removal/burial of prey species; turbidity/siltation effects; contaminant resuspension; noise/disturbance; alterations to hydrodynamic regime and physical habitat; and actual loss of riparian habitat (Chytalo 1996; Winger et al. 2000). According to Smith and Clugston (1997), dredging and filling affect important habitat features of Atlantic Sturgeon as they disturb benthic fauna, eliminate deep holes, and alter rock substrates.

In the South Atlantic DPS, maintenance dredging is currently modifying Atlantic Sturgeon nursery habitat in the Savannah River. Modeling indicates that the proposed deepening of the navigation channel will result in reduced DO and upriver movement of the salt wedge, restricting spawning habitat. Dredging is also modifying nursery and foraging habitat in the St. Johns River. For the Carolina DPS, dredging in spawning and nursery grounds modifies the quality of the habitat and is further restricting the extent of available habitat in the Cape Fear and Cooper Rivers, where Atlantic Sturgeon habitat has already been modified and restricted by the presence of dams.

3.2.4.3 Water Quality

Atlantic Sturgeon rely on a variety of water quality parameters to successfully carry out their life functions. Low DO and the presence of contaminants modify the quality of Atlantic Sturgeon habitat and in some cases, restrict the extent of suitable habitat for life functions. Secor (1995) noted a correlation between low abundances of sturgeon during this century and decreasing water quality caused by increased nutrient loading and increased spatial and temporal frequency of hypoxic (low oxygen) conditions. Of particular concern is the high occurrence of low DO coupled with high temperatures in the river systems throughout the range of the Carolina and South Atlantic DPSs in the Southeast. Sturgeon are more highly sensitive to low DO than other fish species (Niklitschek and Secor 2009a; Niklitschek and Secor 2009b) and low DO in combination with high temperature is particularly problematic for Atlantic Sturgeon. Studies have shown that juvenile Atlantic Sturgeon experience lethal and sublethal (metabolic, growth, feeding) effects as DO drops and temperatures rise (Niklitschek and Secor 2005; Niklitschek and Secor 2009a; Niklitschek and Secor 2009b; Secor and Gunderson 1998). In the Neuse River, Oakley (2003) recorded prolonged periods of low DO in many sections of the river, and found that a juvenile Atlantic Sturgeon that was tracked via radio telemetry tagging tended to avoid hypoxic river reaches.

Reductions in water quality from terrestrial activities have modified habitat utilized by the South Atlantic DPS. Low DO is modifying sturgeon habitat in the Savannah due to dredging, and non-point source inputs are causing low DO in the Ogeechee River and in the St. Marys River, which completely eliminates juvenile nursery habitat in summer. Low DO has also been observed in the St. Johns River in the summer. In the Pamlico and Neuse systems occupied by the Carolina DPS, nutrient-loading and seasonal anoxia are occurring, associated in part with concentrated animal feeding operations (CAFOs). Oakley (2003) concluded that “recovery of dissolved oxygen levels and decreased nutrient loading must occur” before the Shortnose Sturgeon could be restored in the Neuse River. These water quality issues may also be a factor in the reason for the low population numbers of Atlantic Sturgeon in the Neuse River.

Atlantic Sturgeon are inherently susceptible to effects from exposure to toxicants in the substrate, such as heavy metals, given their benthic foraging behavior and long-lived traits (Atlantic

Sturgeon Recovery Team 2007). Dwyer et al. (2000) demonstrated that Atlantic Sturgeon fry were more sensitive to copper sulfate and four other contaminants (contaminants carbaryl, 4-nonylphenol, pentachlorophenol, and permethrin) than fathead minnow (*Pimephales promelas*), sheepshead minnow (*Cyprinodon variegatus*), and rainbow trout (*Oncorhynchus mykiss*), which are three common toxicity test species. As mentioned in Section 3.1.2, the Neuse River within the Action Area is currently listed on the 303 (d) list of impaired waters due to copper; although in the most recent update it has been proposed to be removed as it may no longer exceed copper levels.

Heavy industrial development and CAFOs have degraded water quality in the Cape Fear River. Water quality in the Waccamaw and Yadkin-Pee Dee Rivers has been affected by industrialization and riverine sediment samples contain high levels of various toxins, including dioxins. Decreased water quality also threatens Atlantic Sturgeon of the Chesapeake Bay DPS, especially since the Chesapeake Bay system is vulnerable to the effects of nutrient enrichment due to a relatively low tidal exchange and flushing rate, large surface-to-volume ratio, and strong stratification during the spring and summer months (ASMFC 1998; ASSRT 2007; Pyzik et al. 2004). These conditions contribute to reductions in DO levels throughout the bay. The availability of nursery habitat, in particular, may be limited given the recurrent hypoxia (low DO) conditions within the Bay (Niklitschek and Secor 2005; Niklitschek and Secor 2010).

3.2.4.4 Water Quantity

Water allocation issues are a growing threat in the Southeast and exacerbate existing water quality problems. Taking water from one basin and transferring it to another fundamentally and irreversibly alters natural water flows in both the originating and receiving basins, which can affect DO levels, temperature, and the ability of the basin of origin to assimilate pollutants (GWC 2006). Water quality within the river systems in the range of the South Atlantic and Carolina DPSs is negatively affected by large water withdrawals. Known water withdrawals of over 240 million gallons per day are permitted from the Savannah River for power generation and municipal uses. However, permits for users withdrawing less than 100,000 gallons per day are not required, so actual water withdrawals from the Savannah and other rivers within the range of the South Atlantic DPS are likely much higher. In the range of the Carolina DPS, 20 interbasin water transfers in existence prior to 1993, averaging 66.5 million gallons per day (mgd), were authorized at their maximum levels without being subjected to an evaluation for certification by the North Carolina Department of Environmental Quality or other resource agencies. Since the 1993 legislation requiring certificates for transfers, almost 170 mgd of interbasin water withdrawals have been authorized, with an additional 60 mgd, pending certification. The removal of large amounts of water from these systems will alter flows, temperature, and DO. Water shortages and “water wars” are already occurring in the rivers occupied by the South Atlantic and Carolina DPSs and will likely be compounded in the future by population growth and potentially by climate change.

3.2.4.5 Climate Change

The Intergovernmental Panel on Climate Change (IPCC) projects with high confidence that higher water temperatures and changes in extremes, including floods and droughts, will affect water quality and exacerbate many forms of water pollution—from sediments, nutrients, dissolved organic carbon, pathogens, pesticides, and salt, as well as thermal pollution—with possible negative effects on ecosystems (IPCC 2008). In addition, sea level rise is projected to extend areas of salinization of groundwater and estuaries, resulting in a decrease of freshwater availability for humans and ecosystems in coastal areas. Some of the most heavily populated areas are low-lying, and the threat of salt water entering into its aquifers with projected sea level rise is a concern (USGRG 2004). Existing water allocation issues would be exacerbated, leading to an increase in reliance on interbasin water transfers to meet municipal water needs, further stressing water quality.

Dams, dredging, and poor water quality have already modified and restricted the extent of suitable habitat for Atlantic Sturgeon spawning and nursery habitat. Changes in water availability (depth and velocities) and water quality (temperature, salinity, DO, contaminants, etc.) in rivers and coastal waters inhabited by Atlantic Sturgeon resulting from climate change will further modify and restrict the extent of suitable habitat for Atlantic Sturgeon. Effects could be especially harmful since these populations have already been reduced to low numbers, potentially limiting their capacity for adaptation to changing environmental conditions (Belovsky 1987; Salwasser et al. 1984; Soulé 1987; Thomas 1990).

The effects of changes in water quality (temperature, salinity, DO, contaminants, etc.) in rivers and coastal waters inhabited by Atlantic Sturgeon are expected to be more severe for those populations that occur at the southern extreme of the Atlantic Sturgeon's range, and in areas that are already subject to poor water quality as a result of eutrophication. The South Atlantic and Carolina DPSs are within a region the IPCC predicts will experience overall climatic drying (IPCC 2008). Atlantic Sturgeon from these DPSs are already susceptible to reduced water quality resulting from various factors: inputs of nutrients; contaminants from industrial activities and non-point sources; and interbasin transfers of water. In a simulation of the effects of water temperature on available Atlantic sturgeon habitat in Chesapeake Bay, Niklitschek and Secor (2005) found that a 1°C increase of water temperature in the bay would reduce available sturgeon habitat by 65%.

3.2.4.6 Vessel Strikes

Vessel strikes are a threat to the Chesapeake Bay and New York Bight DPSs. Eleven Atlantic Sturgeon were reported to have been struck by vessels on the James River from 2005 through 2007. Several of these were mature individuals. From 2004-2008, 29 mortalities believed to be the result of vessel strikes were documented in the Delaware River; at least 13 of these fish were

large adults. The time of year when these events occurred (predominantly May through July, with two in August), indicate the animals were likely adults migrating through the river to the spawning grounds. Because we do not know the percent of total vessel strikes that these observed mortalities represent, we are not able to quantify the number of individuals likely killed as a result of vessel strikes in the Chesapeake and New York Bight DPSs. Vessel strikes within the Action Area are likely not a major threat, however such a scenario is plausible.

3.2.4.7 Bycatch Mortality

Overutilization of Atlantic Sturgeon from directed fishing caused initial severe declines in Atlantic Sturgeon populations, from which they have never rebounded. Further, continued overutilization of Atlantic Sturgeon as bycatch in commercial fisheries is an ongoing impact to Atlantic Sturgeon in all 5 DPSs. Atlantic Sturgeon are more sensitive to bycatch mortality because they are a long-lived species, have an older age at maturity, have lower maximum reproductive rates, and a large percentage of egg production occurs later in life. Based on these life history traits, Boreman (1997) calculated that Atlantic Sturgeon can only withstand the annual loss of up to 5% of their population to bycatch mortality without suffering population declines. Mortality rates of Atlantic Sturgeon taken as bycatch in various types of fishing gear range between 0% and 51%, with the greatest mortality occurring in sturgeon caught by sink gillnets. Currently, there are estimates of the number of Atlantic Sturgeon captured and killed in sink gillnets and otter trawl fisheries authorized by Fishery Management Plans (FMPs) in the Northeast Region (Miller and Shepherd 2011). Those estimates indicate from 2006-2010, on average there were 1,548 and 1,569 encounters per year in observed gillnet and trawl fisheries, respectively, with an average of 3,118 encounters combined annually. Mortality rates in gillnet gear were approximately 20%, while mortality rates in otter trawl gear are generally lower, at approximately 5%. Atlantic Sturgeon are particularly vulnerable to being caught in sink gillnets; therefore, fisheries using this type of gear account for a high percentage of Atlantic Sturgeon bycatch. Atlantic Sturgeon are incidentally captured in state and federal fisheries, reducing survivorship of subadult and adult Atlantic Sturgeon (ASMFC 2007; Stein et al. 2004). Little data exists on bycatch in the Southeast and high levels of bycatch underreporting are suspected. However, fisheries known to incidentally catch Atlantic Sturgeon occur throughout the marine range of the species and in some riverine waters as well. Because Atlantic Sturgeon mix extensively in marine waters and may access multiple river systems, they are subject to being caught in multiple fisheries throughout their range. In addition, stress or injury to Atlantic Sturgeon taken as bycatch but released alive may result in increased susceptibility to other threats, such as poor water quality (e.g., exposure to toxins and low DO). This may result in reduced ability to perform major life functions, such as foraging and spawning, or even post-capture mortality.

3.2.5 *Potential Effects of Roadway Projects on Atlantic Sturgeon*

There are a number of potential direct and indirect effects to Atlantic Sturgeon and their habitat that can result from roadway construction projects. In addition to direct effects that occur during roadway construction, the roadway project can continue to result in indirect effects associated with the roadway post construction (operational effects), as well as indirect effects associated with project-induced development. While several threats are recognized, potential roadway-related effects on aquatic species and habitat fall into three main categories:

1. Physical effects (habitat degradation, direct mortality of individuals),
2. Water quality effects (chemical, temperature, and biological pollutants), and
3. Water quantity effects (changes in peak and base flows).

3.2.5.1 Physical Effects

Roadway construction can result in physical effects to individual fish as well as to their habitat. Physical effects associated with road construction include, but are not limited to, riparian land-clearing, physical loss of habitat (substrate fill), stream re-channelization, hydrologic modification, erosion associated with construction both in the project corridor and within fill/borrow areas, and construction staging/access areas outside of the project corridor. The potential effects of these activities on aquatic species, specifically Atlantic Sturgeon, include physical effects to egg and larval habitat from substrate disturbance/fill, channel and stream bank scouring, channel erosion, and sedimentation, all of which reduces habitat suitability.

Acoustic, or noise, effects to fish can occur from bridge construction/demolition activities such as blasting, pile driving and causeway placement. Underwater sound waves emitting from these actions can cause tissue damage to fish that can be lethal. The recovery plan for the Shortnose Sturgeon (NMFS 1998) identified blasting activities associated with bridge construction and demolition as having the potential to affect the species by damaging the swim bladder from shock waves. Atlantic Sturgeon are expected to be similarly affected. There are several factors which affect the level of impact, including frequency, sound pressure, acoustic impulse, and distance from source (Caltrans Office of Environmental Engineering 2001). Anatomical and physiological traits of the fish species may also influence their susceptibility to sound effects. The size of the fish also influences sensitivity to sound effects, as larger fish appear to be able to withstand a larger sound impulse than small sized fish (Caltrans Office of Environmental Engineering 2001, Yelverton et al. 1975). A further summary of the effects of acoustics on fish, including bridge construction related effects, are provided in Caltrans Office of Environmental Engineering (2001) and references contained within and the Draft Programmatic Biological Evaluation – Appendix A (NMFS 2017b).

3.2.5.2 Water Quality Effects

Roadway construction can result in a variety of chemical and thermal water quality effects during construction as well as from induced land use changes post-construction. These effects include the addition of various chemical and thermal pollutants to waterways originating from the project construction and facility footprint, as well as and those pollutants originating from induced land use changes, particularly pollutants from commercial and/or residential developments (e.g., urban runoff, fertilizers, pesticides). Various parameters that serve as proxies for chemical and thermal water quality effects were modeled for the Complete 540 project for a Build vs. No-Build scenario, including Impervious Surface, Total Nitrogen (TN) and Total Phosphorous (TP) (Section 4.3).

3.2.5.3 Water Quantity Effects

Water quantity effects are temporary and permanent alteration of flows. These include construction effects (e.g., temporary dewatering, causeway construction, and channel restriction), which are qualitatively assessed in Section 4.1, as well as effects from induced land use changes (increased runoff and storm flows, decreased infiltration and associated base flow). The amount of impervious surface levels in the subject watersheds was modeled for the project as a proxy for water quantity effects associated with induced land use changes (Section 4.3).

3.2.6 Designated Critical Habitat

Any Atlantic Sturgeon spawned in U.S. waters are protected under the ESA as five DPSs. The four DPSs - New York Bight, Chesapeake Bay, Carolina, and South Atlantic - were listed as endangered on February 6, 2012. As of February 6, 2012, the Gulf of Maine DPS was listed as threatened. The Gulf of Maine, New York Bight, and Chesapeake Bay DPSs are under the jurisdiction of the Greater Atlantic Region of National Oceanic and Atmospheric Administration (NOAA) Fisheries Service. The Carolina and South Atlantic DPSs are under the jurisdiction of the NOAA Fisheries Service, Southeast Region (NMFS 2017a). The Carolina Unit 3 is listed as the following in the Federal Register:

“Carolina Unit 3, Neuse Unit. Neuse River in Carteret, Craven, Duplin, Johnston, Lenoir, Pamlico, Pitt, Wake, and Wayne Counties in North Carolina.

Carolina Unit 3 includes the Neuse River main stem from the Milburnie Dam downstream to RKM 0. The Neuse River, one of two major tributaries to Pamlico Sound, is dammed. It is likely that Atlantic sturgeon historically utilized habitat in the Neuse River up to the falls at RKM 378 where a dam (Falls Dam) is now located, although this site is above the fall line (ASSRT, 2007). Spawning migration may be impeded to historic habitat above the Milburnie Dam (RKM 349).”

Various Physical and Biological Features (PBFs) have been identified as essential components of the Critical Habitat to conserve the Atlantic Sturgeon (NMFS 2017b). These PBFs and their associated conservation value include:

1) Hard bottom substrate (e.g., rock, cobble, gravel, limestone, boulder, etc.) in low salinity waters (i.e., 0.0-0.5 parts per thousand range) for settlement of fertilized eggs and refuge, growth, and development of early life stages.

(2) Transitional salinity zones inclusive of waters with a gradual downstream gradient of 0.5 up to as high as 30 parts per thousand and soft substrate (e.g., sand, mud) between the river mouth and spawning sites for juvenile foraging and physiological development.

(3) Water of appropriate depth and absent physical barriers to passage (e.g., locks, dams, thermal plumes, turbidity, sound, reservoirs, gear, etc.) between the river mouth and spawning sites necessary to support (i) Unimpeded movement of adults to and from spawning sites, (ii) Seasonal and physiologically dependent movement of juvenile Atlantic Sturgeon to appropriate salinity zones within the river estuary; and (iii) Staging, resting, or holding of subadults or spawning condition adults. Water depths in main river channels must also be deep enough (at least 1.2 meters) to ensure continuous flow in the main channel at all times when any sturgeon life stage would be in the river.

(4) Water quality conditions, especially in the bottom meter of the water column, with temperature and oxygen values that support (i) Spawning; (ii) Annual and inter-annual adult, subadult, larval, and juvenile survival; and (iii) Larval, juvenile, and subadult growth, development, and recruitment.

3.2.6.1 Physical Conditions of Critical Habitat in Project Footprint

The proposed project crossing location of the Neuse River occurs at approximately RKM 338. The general substrate in the Johnston County and eastern Wake County section of the Neuse River is dominated by shifting sand and soft clay banks, with sporadic pockets of gravel, cobble, boulder and bedrock.

The specific physical habitat conditions within the project footprint were qualitatively evaluated on November 17, 2017, by wading and recording substrate composition and water depth along cross river transects of the centerline and upstream and downstream limits of the proposed crossing. The water depth in most of the crossing location is six inches or less, and there is a large mid-channel sand bar (Photo 1) that is exposed during base flow. The deepest sections of the river occur adjacent to both banks, with a maximum depth of 2.5 feet along the right descending bank and a maximum of 4.5 feet on the left descending bank. These deeper thalweg areas are narrow (<25 feet in width).



Photo 1. Mid-channel sand bar at proposed crossing of Neuse River

Other than a minor small gravel component in limited areas, there was no concentration of any hard substrate (e.g., gravel, cobble, bedrock), which are identified as PBFs essential to the conservation of the species (NMFS 2017b). Habitat characterization transects were also performed at 115 and 290 feet above and 120 and 400 feet below the proposed crossing and similar conditions were present. Figure 8 depicts the general substrate composition of the river at that project crossing. A complete discussion of the habitat evaluation results are included in Appendix B.

4.0 EFFECTS OF PROPOSED ACTION ON ATLANTIC STURGEON AND CRITICAL HABITAT

The potential direct and indirect effects to the Atlantic Sturgeon and critical habitat discussed above were evaluated for the Build vs No-Build and scenarios. The project related effects are presented in three categories:

- 1) Construction Effects
- 2) Operational Effects
- 3) Induced Land Development Effects

Measures that have been incorporated into the development of this project to avoid or minimize effects (Section 4.4.4) to the Atlantic Sturgeon and critical habitat are included in this evaluation.

4.1 Construction Effects Evaluated

The project crosses the Neuse River, which is considered occupied habitat in accordance with the critical habitat designation. In addition, the project alignment crosses multiple streams that

eventually drain to the Neuse River. While there is the potential for construction related effects from any jurisdictional crossing within the watershed, the likelihood of such effects generally declines the further the action is from occupied habitat. Potential effects are even further reduced if the stream drains into an impoundment, prior to reaching occupied habitat, such as Austin Pond on White Oak Creek.

4.1.1 Stream Fill (Substrate (Habitat) Disturbance/Loss)

Highway construction within and around water bodies often results in the placement of fill into streams and adjacent floodplains. Two types of fill may occur, permanent and temporary. Permanent fills consist of bridge piers and abutments, culvert and pipe construction or extensions, and roadway fill slopes. Construction causeways and work bridges used for equipment access are examples of temporary fill.

4.1.2 Noise Effects

As mentioned in Section 3.2.5.1 noise effects from bridge construction has been identified as a threat to sturgeon. The project will involve construction of a new bridge in the Neuse River at RKM 338, which will require installation of piers within the river.

4.1.3 Erosion/Sedimentation from Construction

The amount of sedimentation/erosion that will result from project construction and the level to which it adversely affects the Atlantic Sturgeon is difficult to predict and is dependent on several factors, such as the frequency and duration of rainfall events during construction that exceed the erosion control design devices, construction duration, adherence to proper maintenance of erosion control devices, and the promptness to respond and remediate erosion control failures.

4.1.4 Alteration of Flows/Channel Stability

Stream channel instability can result from bridge construction and culvert/pipe crossings. Natural stream stability is achieved when the stream exhibits a stable dimension, pattern, and profile such that over time, the channel features are maintained, and the channel neither aggrades, nor degrades. Channel instability occurs when scour results in degradation, or when sediment deposition leads to aggradation (Rosgen 1996). The placement of fill, such as bridge piers, culverts, pipes, and causeways, into streams can alter the normal flow pattern of a water body by reducing flow velocities upstream, increasing sedimentation and flow velocities downstream, and resulting in scour and erosion.

4.1.5 Effects Associated with Borrow/Fill, Staging and Storage

The contractor may use areas within the Neuse River watershed for staging, storage, refueling, borrow pit, or spoil areas. Borrow pits and spoil areas will be excluded from stream buffer areas per existing Neuse River buffer regulations and Wake County, Johnston County, and Town of Garner local ordinances. However, areas outside of the buffers still have the potential to affect water quality through sedimentation, erosion, and introduction of toxic compounds into streams via stormwater channels, ditches, and overland runoff or through losses during the hauling process. The extent and magnitude of these effects is dependent upon distance to occupied habitat, as well as soils and topography, which influence transport of sediment and toxicants to occupied habitat. The potential for these effects to occur can be minimized by developing measures to control sedimentation, erosion, and introduction of toxic compounds from entering streams in these areas.

4.1.6 Effects Associated with Geotechnical Drilling

Geotechnical drilling to determine subsurface characteristics for bridge construction or for potential subsurface crossings for utility lines, may be performed throughout the project alignment, including the Neuse River. Given that the project bridge on the Neuse River is a new alignment crossing, it is unlikely that utility lines will be located at the bridge. The drill shaft is lubricated using a mixture of bentonite (a natural, inert clay material) and water which is filtered and recycled back through the drilling operation. However, there is always the possibility that some of the drilling slurry could be discharged either directly into river or through runoff. Accessing sampling locations also results in limited vegetation removal, though grubbing is rarely required. Subsurface sampling for hazardous materials may also be necessary for this project. Durations will vary for these activities depending on number of bore holes and substrate composition. Since geotechnical investigations can be completed relatively quickly, they are more easily scheduled to avoid adverse weather events which further minimizes the potential discharge and adverse effects. Boring through the substrate could potentially adversely affect Atlantic Sturgeon eggs that are adhered to the substrate, or newly hatched larvae, which have a close affinity to the substrate (Section 3.2.2).

4.2 Operational Effects Evaluated

Operational effects include effects that arise from maintenance and daily vehicular use of the facility once it is in operation, as well as natural responses over time to the proposed action's construction effects that occur post-construction.

4.2.1 Alteration of Flows/Channel Stability

Once construction is completed, stream channel instability can occur over time as streams adjust to the channel alterations from construction, which could eventually affect critical habitat. The

constructed project road network within a watershed can be a factor affecting channel stability as it contributes to changing of the timing and volume of peak flows, intercepting subsurface water, and decreasing the time for overland runoff to reach the stream channel. The specific factors that influence the potential for the crossing structures outside of the defined area of construction related effects to adversely affect occupied habitats as a result of destabilization of the stream channel include, but are not limited to:

- design of the structure
- distance of crossing structure to critical habitat
- watershed size
- stream gradient and characteristics (i.e., presence of natural grade control such as bedrock outcropping)
- low gradient pools, or beaver dams and other structures that may attenuate flow velocity, as well as conditions and changes to the watershed including development and road network.

As a result, even though a watershed receives the same amount of precipitation, it is transported through the system much more quickly, thus resulting in higher peak discharges and resultant increases in stream power.

This increased stream power can more effectively erode the streambed and banks (Castro 2003). While any crossing structure (e.g., bridges, culverts, and pipes) can lead to channel instability, culverts have historically been particularly problematic. Culverts have often led to channel instability by constricting the flow, which increases the erosional forces. Historically, the design of culverts only accounted for the passing of water, and not bed materials, sediment, and woody debris. As such, significant problems at culverts have occurred including “(1) plugging due to large wood transport, (2) sediment deposition at the inlet due to the backwater effect, and (3) high velocity flows exiting the culvert resulting in channel scour” (Castro 2003). Channel instability associated with a culvert crossing is not static, rather they can be far reaching and affect the channel, and in turn the aquatic community, for considerable distances both upstream and downstream, as “streams are linear systems that move mass and energy along the channel primarily in upstream/downstream directions and through the floodplain in all directions” (Castro 2003).

4.2.2 Roadway Runoff

Numerous pollutants have been identified in highway runoff, including various metals (e.g., lead, zinc, iron), sediment, pesticides, deicing salts, nutrients (nitrogen, phosphorus), and petroleum hydrocarbons. There are 77 jurisdictional stream crossings draining to critical habitat along the Complete 540 alignment that can potentially increase Atlantic Sturgeon exposure to roadway runoff.

4.2.3 Toxic Spills

Roadway construction can also affect the aquatic environment by increasing the potential for toxic spills from vehicular accidents once the facility is in operation. The type (e.g., commercial truck) and volume of traffic affect the potential for toxic spills to occur. There is no way to accurately predict when and where toxic spills will occur. The Texas Department of Transportation and the FHWA commissioned a study that evaluated roadway hazardous material spill incidents associated with transportation on Texas highways. The study found that between 2002–2006, more than 900 hazardous material spills of varying volumes were recorded in the state, and it was speculated that rainy/wet roadway conditions may be a factor in the frequency of spills. The results were used to develop design guidelines and parameters to reduce the risk of exposure to travelers and individuals responsible for spill cleanup (Thompson et al. 2011).

4.3 *Induced Land Development Effects Evaluated*

Roadway construction can influence land use and result in development that would not occur without the road (induced development). While land development itself does not affect Atlantic Sturgeon and their habitat, increases in sediment loads and various pollutants, alterations in flow regime (base flow and peak discharge), and loss of riparian buffers are consequences of development that lead to water quality degradation.

Baker Engineering (2017) completed a Quantitative Indirect and Cumulative Effects (ICE) Report of the Complete 540 Project using a methodology to forecast land use changes between the base year of 2011 and design year of 2040. This Quantitative ICE report utilized much of the information in the Qualitative ICE Report (H.W. Lochner 2014). The primary changes in land development from the No-Build to Build are higher land use densities, more commercial and industrial development, and a greater mix of uses in the areas surrounding the interchanges. Though this pattern is captured in the model results, it is noted without the project, there would be both less development overall and lower densities of development in the FLUSA. However, there does not appear to be a more sprawled development pattern in the FLUSA in the Build scenario. While this modeling can predict the general trends in land use changes associated with the project, the specific type of development and the exact locations cannot be determined. Furthermore, as discussed in the ICE Memoranda and Water Quality Assessment (Baker Engineering 2017a, 2017b, 2017c, and 2017d), there are a number of development restrictions in place within the Action Area, such as Neuse Buffer Rules and designated Environmentally Sensitive Areas (ESAs), that would lessen some of the potential for project induced development.

The predictive watershed model utilized in the analysis and documented in the Quantitative ICE Report (Baker Engineering 2017c) was run twice for each land use scenario (2040 No-Build and 2040 Build) to estimate the low- and high-limits of potential induced and cumulative effects to the water quality study area. For both model runs, the process described in Quantitative ICE Memo #2 (Baker Engineering, 2017b) was used to calculate land cover in the water quality study area. The first, more-conservative model run, Model Run 1, produced an “upper limit” of percent impervious coverage for each HUC in the study area, while the second model run, Model Run 2, produced a “lower limit” of impervious coverage for the 2040 No-Build, and 2040 Build scenarios, with the expected outcome to be closer to the mid-range of these limits. The results of the impervious surface models were then used to model several water quality parameters, the results of which are provided in Quantitative ICE Memo #3 (Baker Engineering., 2017c).

Critical Habitat Units for the Atlantic Sturgeon were not designated when the ICE analysis was performed. The water quality parameters that were selected for modeling were chosen due freshwater mussels sensitivity to those constituents such as copper and total suspended solids (TSS), since, as mentioned in Section 3.2, two federally listed mussel species the Dwarf Wedgemussel and the Yellow Lance were addressed in the BA submitted to the USFWS on December 6, 2017. However, these parameters are also applicable to Atlantic Sturgeon, as sedimentation, and exposure to heavy metals, including copper were identified as threats to the species (Atlantic Sturgeon Recovery Team 2007). Therefore, we feel no additional parameters warranted modeling specifically for the Atlantic Sturgeon or critical habitat. The following parameters were modeled:

- Impervious Surface
- Annual streamflow
- Annual runoff
- Annual total suspended solids (TSS)
- Annual total nitrogen (TN)
- Annual total phosphorus (TP)
- Annual copper (Cu)

As noted, Model Run 2 provides a lower limit estimate, and Model Run 1 provides an upper limit estimate. As such, results within the five pertinent subbasins and entire water quality study area are provided in Table 8 as a range (i.e., <1-3%) of the difference between the two models for the 2040 No-Build and 2040 Build. If there are no differences in the two models, then the result is provided as the single value (i.e., 2%).

Table 8. Water Quality Parameters Percent Change from Build to No-Build Within Five Pertinent Subbasins

Parameter	Lower Middle Creek	Reed Branch-Swift Creek	Walnut Creek	Poplar Creek-Neuse River	Lower Crabtree Creek	Entire Water Quality Study Area
Impervious Surface	<1-1%	<1%	<1%	<1-3%	<1%	<1-1%
Annual Streamflow	<1%	<1%	<1%	<1-1%	<1%	<1%
Annual Runoff	1-3%	<1-1%	<1%	<1-6%	<1%	<1-2%
Annual TSS	3%	2%	<1%	<1%	<1%	<1%
Annual TN	<1%	<1%	<1%	<1%	<1%	<1%
Annual TP	2%	<1-1%	<1%	<1-4%	<1%	<1%
Annual CU	3%	2%	<1%	<1%	<1%	<1%

When considering the entire water quality study area (last column of Table 8), the range of differences between the No-Build and Build scenarios for all but one of the modeled parameters is less than or equal to 1% even with the upper limit (Model Run 1) estimate. The one exception is annual runoff, which is 2% with the upper limit estimate. The slightly higher result in annual runoff is also noted in the five pertinent subbasins as the overall highest upper limit result of 6% increase in the Poplar Creek-Neuse River subbasin.

With the exception of streamflow and runoff projected in Model Run 1, these increases, as well as the maximum observed increase between the 2040 Build and 2040 No-Build scenarios, were observed to be within the standard error range of each pollutant as modeled (see Table 19 in Baker Engineering 2017c). Results within the standard error cannot be distinguished from a random occurrence (Baker Engineering 2017c). For Model Run 1, streamflow and runoff exceeded the standard error, but are relatively small. Further, as stated above, the actual outcome is expected to be closer to the mid-range of the of the lower and upper limit estimates, or something less than the results of Model 1.

4.3.1 Induced Roadway Runoff Effects

Induced changes in land use also has the potential to affect traffic patterns on the existing road network within the action area of roadway construction projects, which in turn result in changes of pollutant concentration of roadway runoff exposure within occupied habitats. Increased traffic volumes on the road networks traversing the watersheds could potentially affect the associated aquatic communities by causing water quality degradation via an increase in runoff contaminants attributable to the additional traffic. Increased traffic volumes may also result in the need for widening and improvements to existing roads that occur within the Action Area, further increasing runoff from both construction and increased stormwater flows from the additional impervious surface. Widening of existing roadways could also result in increased exposure to thermal pollutants due to a larger impervious footprint of the respective roadways. Decreases in

traffic volume could have a potential localized beneficial effect by decreasing concentrations of toxicants originating from roadway runoff, and/or toxic spills along roadways.

Induced effects from roadway runoff fall into two categories; 1) increases/decreases in roadway runoff due to changes in traffic patterns on the existing roadway network within occupied watersheds, and 2) roadway runoff originating from project crossings of waters within occupied watersheds.

The forecasted traffic levels indicate that the induced growth effects of the proposed project will likely add to the total volume of traffic in Wake and Johnston Counties and to the total Vehicle Miles Traveled (VMT) and Vehicle Hours Traveled (VHT). Roads that connect to Complete 540 will likely see some increases in traffic, mostly in the immediate vicinity of interchanges. The traffic analysis (HNTB 2017) of FLUSA-Level traffic conditions showed that while total Daily and PM Peak VMT/VHT slightly increased with Complete 540 in place, the congested Daily and PM Peak VMT/VHT, average Daily and PM Peak speeds, and Daily and PM Peak congested roadway mileage all improved in the Build condition. Additionally, the volume-to-capacity comparisons showed that all areas with a Level of Service of “E” or worse had Triangle Regional Model daily volume-to-capacity ratios within the same threshold in the model runs both Future-Year Build conditions (No-Build and Build). This indicates that these issues would exist with or without the project.

There are multiple crossings of water bodies within the five pertinent subbasins all of which eventually drain to critical habitat; thus, there is potential for Atlantic Sturgeon and the habitat to be exposed to various toxicants originating from these crossings. Numerous factors influence the potential for these toxicants to reach critical habitats:

- traffic volumes
- distance of crossing structure to critical habitat
- watershed size
- stream gradient and characteristics (i.e. presence of natural low gradient pools, or beaver dams and other structures that may attenuate transport of toxins, etc.)
- toxin attributes that affect exposure pathways (i.e. bound to sediment).

The magnitude of the effects associated with roadway runoff originating from a specific crossing is dependent on the transport mechanisms described above, coupled with the amounts of toxicants entering occupied habitat via other pathways (other tributaries, atmospheric deposition, run off from adjacent land use, ground water inputs, etc.).

4.4 Conclusions of Effects –Atlantic Sturgeon & Critical Habitat

After evaluating the project related effects within the three categories (Construction, Operational and Induced Land Development), conclusions of the specific ways in which the Atlantic Sturgeon and the critical habitat will be affected by the three aspects of the action are given. These effects are then summarized in the context of effects to the species and the individual PBFs of Critical Habitat. The conclusion of effects of the project to Atlantic Sturgeon and Atlantic Sturgeon critical habitat follows.

4.4.1 Construction Effects

The construction of Complete 540 has the potential to have the following construction related effects on the Atlantic Sturgeon and critical habitat as described below.

4.4.1.1 Stream Fill (Substrate (Habitat) Disturbance/Loss)

The crossing of Neuse River is designed to have spans installed generally in, or just inside, either bank of the river permanently impacting approximately 500 square feet of river substrate. The conceptual bridge design is provided in Figures 9 and 10. Temporary causeways are anticipated for bridge construction. Each causeway will extend from either bank approximately 55-feet into the river, and have cross pipes to maintain water flow. Each causeway will total approximately 8,000 square feet. Although their presence in this section of the Neuse River is unlikely, to avoid potential effects to migrating Atlantic Sturgeon, no construction will occur within the Neuse River from August 15 – October 31. In the even further unlikely event that Atlantic Sturgeon are in this section of the river outside of this moratorium, at least 50% of the river will always remain unobstructed, which will allow Atlantic Sturgeon passage throughout the life of the project.

Based upon the site investigation of the physical conditions of the critical habitat within the project footprint performed in November 17, 2017 (Figure 8), there are no concentrations of PBFs within the footprint or immediate vicinity of the bridge bents. Similar habitat conditions were found within the 850-foot-wide study corridor both upstream and downstream of the crossing area. Further, the project will adhere to the specific Project Design Criteria (PDCs) in Appendix C. As such, effects to PBF within the critical habitat unit from the temporary causeways and bridge bents are not expected and discountable.

4.4.1.2 Noise Effects

Pile installation will use drilled shafts, which is the method that produces the least amount of noise. While the drilled shafts will be larger than the 36-inch diameter threshold of the Draft Programmatic Biological Evaluation (DPBE) (NLAA) on the Effects of Transportation Activities and Projects Undertaken in North Carolina, South Carolina, and Georgia” in August 2017

(NMFS 2017b), given the location of the project in a lotic river with running water (as opposed to estuaries or slack water runs), noise effects from drilled shafts to Atlantic Sturgeon if present are anticipated to be insignificant. Further with adherence to the August 15-October 31 moratorium, it is very unlikely that Atlantic Sturgeon will be in this section of the river during drilled shaft operations; thus, noise effects are also considered discountable.

4.4.1.3 Erosion/Sedimentation from Construction

NCDOT has committed to using the Design Standards in Sensitive Watersheds [15A NCAC 04B .0124 (b) – (e)] throughout the project, which will reduce the potential for adverse effects. Further, the project will adopt specific PDCs in Appendix C. These measures are being applied as applicable to each stream crossing of the project as well as the Neuse River crossing. While the potential for these effects cannot be absolutely eliminated, sedimentation/erosion related adverse effects to the Atlantic Sturgeon and critical habitat are very unlikely to occur or would be insignificant.

4.4.1.4 Alteration of Flows/Channel Stability

The proposed bridge design and construction methodology are based upon the recently constructed Auburn-Knightdale Bridge crossing of the Neuse River approximately 0.4 RM upstream (Figure 11). The general flow pattern and cross-section of the river is similar at both locations. As was used at the Auburn-Knightdale Bridge, temporary causeways will be installed from each bank to construct the permanent bridge bents. Each causeway will extend into the river approximately 55-feet, be made of cleaned rip-rap placed on geofabric (as practicable as possible), and have cross pipes to maintain flow. At least 50% of the river will always remain unobstructed. The project will also adopt the specific PDCs in Appendix C.

Invariably, construction of the temporary causeways, which may be in place a maximum of 24-months (though never during the August 15 – October 31 moratorium), will temporarily alter the river flow. However, once removed the river flow is anticipated to return to the preconstruction flow pattern, as happened at the Auburn-Knightdale Bridge. Riparian buffers will be restored in accordance with NCDOT Reforestation guidelines (Appendix D). Stream banks will be stabilized with appropriately sized riprap. As such, the temporary causeways are not anticipated to permanently alter the flow or channel stability.

4.4.1.5 Effects Associated with Borrow/Fill, Staging, and Storage

Other potential direct effects associated with project construction are sedimentation/erosion and introduction of toxic compounds originating from borrow/spoil, staging, equipment storage, and refueling areas, entering occupied habitat via unregulated stormwater channels, ditches, and overland runoff. At this time, the locations of potential borrow/spoil sites, staging areas, equipment storage areas, and refueling areas have not been chosen. However, these areas are

regulated by NCDOT as part of project construction and will incorporate the specific PDCs in Appendix C. As such, no effects are anticipated from borrow/fill, staging, and storage.

4.4.1.6 Effects Associated with Geotechnical Drilling

To the extent practicable, NCDOT will perform geotechnical drilling outside of the Neuse River channel bed; however, in the event that instream borings are necessary, NCDOT will abide by the conditions and commitments in accordance with Nationwide Permit 6. Further, specific PDCs in Appendix C will be adopted. No instream borings will be conducted in the August 15 – October 31 moratorium. As such, effects to sturgeon and critical habitat from geotechnical drilling are discountable.

4.4.2 *Operational Effects*

Operational effects as described in Section 4.2 may occur in the waterbodies listed in Table 2. These effects generally diminish the further they occur from occupied habitat. The predicted effects are based on the Quantitative ICE Assessment Memo #3 (Baker Engineering 2017c), which modeled the percent change from the 2010 Baseline to both the 2040 No-Build and Build by using two model runs, with Model Run 2 providing a lower limit estimate and Model Run 2 an upper limit estimate.

4.4.2.1 Alteration of Flow/Channel Stability

The channel at the Auburn-Knightdale Bridge generally seems unaltered as a result of the bridge construction, which is expected to also be the result of the Complete 540 project. While the flow patterns will invariably adapt in some form to the bridge bents post-construction, the adaptation is expected to be minimal and result in no alteration of flow or channel stability and should not adversely affect the conservation values of PBFs in the critical habitat unit.

Once the project has been constructed, there will be other streams draining to the Neuse River that will continue to alter their existing flow/channel stability as they seek equilibrium from construction effects. In addition, the road network that evolves due to Complete 540 will affect flow/channel stability as it contributes to the change of the timing and volume of peak flows, intercepting subsurface water, and decreasing overland flow.

The Quantitative ICE Assessment Memo #3 (Baker Engineering 2017b) predicts that in the Neuse River Watershed, the upper limit estimate from 2010 Baseline to No-Build predicts a 13% increase in streamflow, which increases less than 1% from No-Build to Build. Alternatively stated, the increase in streamflow within the entire Action Area due to Complete 540 is less than 1%. Within the five pertinent subbasins, all are also less than 1% except for Poplar Creek – Neuse River Subbasin, where the increase is up to 1%. Further, the Quantitative ICE Assessment Memo #3 (Baker Engineering 2017b) is modeling land use changes within the entire

watershed, of which the operational effects from the facility (Complete 540 project) constitute an immeasurable percentage of the 1% increase. As such, indirect effects to Atlantic Sturgeon and critical habitat from the alteration of flow/channel stability from tributaries flowing into the Neuse River are immeasurable and insignificant.

4.4.2.2 Roadway Runoff

There are multiple streams that will be affected due to the project that drain to the Neuse River. These new sources of roadway runoff, coupled with increased traffic volumes on some of the existing roads within the respective watersheds, may result in a localized increase of the Atlantic Sturgeon's exposure to roadway derived pollutants. However, there may also be localized reductions in exposure to toxicants in other areas within the subbasin of the river as a result of decreased traffic volumes along other roads within the Action Area that drain to river.

The project crossings, particularly the Neuse River crossing, will be designed to comply to maximum extent practicable per existing Neuse River Basin buffer regulations and Wake County, Johnston County and Town of Garner local ordinances that will require runoff be subject to some type of treatment prior to entering jurisdictional streams. Further, NCDOT has committed to eliminating deck drainage directly into any waterbody within the Action Area, as well as a commitment to match the post-discharge to the pre-construction conditions. These actions will reduce the potential for adverse effects from roadway runoff.

The Quantitative ICE Assessment Memo #3 predicts that in the five pertinent subbasins, the highest increase for the 2040 Build lower limit to upper limit scenarios is a 57-96% increase in runoff in the Poplar Creek – Neuse River Subbasin. This represents a range of <1-6% increase from the No-Build. However, as noted in Section 4.4.2.1, the actual amount that is realized in the streamflow is less than 1%. Further, the Quantitative ICE Assessment Memo #3 (Baker Engineering 2017b) is modeling land use changes within the entire watershed, of which the operational effects from the facility (Complete 540 project) constitute an immeasurable percentage of the 1% increase. As such, while it is possible that construction of the Complete 540 project could lead to slightly more exposure to roadway runoff than the No-Build scenario, the effect to Atlantic Sturgeon and critical habitat is expected to be immeasurable and insignificant.

4.4.2.3 Toxic Spills

There is a low potential for adverse effects to occur to the Atlantic Sturgeon because of toxic spills due to vehicular accidents once the facility is in operation. While the potential for adverse effects to Atlantic Sturgeon increases the closer a spill occurs to the Neuse River, there is no way to predict if, where, and when a toxic spill associated with the facility may occur; therefore, such an event is not reasonably certain to occur.

According to the US Department of Transportation, there were 639 reported transportation related incidents involving hazardous materials in North Carolina in 1996 (US DOT 1996). It is even harder to predict the magnitude of the effects to Atlantic Sturgeon if such a spill were to occur along the facility as there are multiple variables, including: actual presence of Atlantic Sturgeon, the toxicity of the contaminants, the amount spilled, and the quantity of river flow. The elimination of deck drains on all project bridges further lessens the potential of adverse effects associated with toxic spills. Given the low probability of Atlantic Sturgeon being present in the Action Area, coupled with the inability to predict if, when and where a toxic spill would occur on the facility, effects associated with toxic spills on the Atlantic Sturgeon are considered unlikely (discountable).

4.4.3 Induced Land Development Effects

The ICE Memoranda and Water Quality Assessment (Baker Engineering 2017a, 2017b, 2017c, and 2017d) analyses, as well as the Qualitative ICE Report (H.W. Lochner 2014), forecast continued increases in developed land and associated water quality degradation in the Neuse River watershed in both the 2040 No-Build and Build scenarios. For the entire Action Area, Quantitative ICE Assessment Memo #2 predicted for the high-end model (Model Run 1) from 2010 Baseline to 2040 No-Build, there is a 12% increase in impervious surface. The high-end model results from 2040 No-Build to 2040 Build further increases the impervious surface by <1%, that with rounding equals 13%, which falls within the standard error range. While this modeling can predict the general trends in land use changes associated with the project, the specific type of development and the exact locations cannot be determined. Furthermore, as discussed in the ICE Memoranda and Water Quality Assessment (Baker Engineering 2017a, 2017b, 2017c, and 2017d), there are a number of development restrictions in place within the Action Area, such as Neuse Buffer Rules and designated Environmentally Sensitive Areas (ESAs), that would lessen some of the potential for project induced development.

When considering the five pertinent subbasins, the modeled parameters that have the most relevance to potential effects on Atlantic Sturgeon are:

- streamflow - primarily due to physical effects to the stream (critical habitat)
- total suspended solids (TSS) – can adversely affect suitability of spawning habitat (critical habitat) and can adversely affect eggs and larvae within the substrate
- total nitrogen - can cause anoxic conditions that are particularly perilous to Atlantic Sturgeon.
- Copper – Atlantic Sturgeon are demonstrated to be sensitive to copper

For both streamflow and total nitrogen, the expected increase from the 2040 No-Build to 2040 Build scenario is <1% in the five pertinent subbasins (Table 8). TSS is expected to increase <1% between 2040 No-Build to 2040 in the five pertinent subbasins, except in the Lower Middle

Creek (3%) and Reed Branch-Swift Creek (2%) subbasins. Copper is also <1%, except in the Lower Middle Creek (3%) and Reed-Branch – Swift Creek (2%) subbasins.

When trying to quantify the effects of the predicted minute increases, one needs to consider site specific BMPs that are required for construction projects, such as bioretention basins, stormwater ponds, and grass swales, as well as the Neuse River Riparian Buffer rules. When taking into account the minute increases attributable to the project with the site specific BMPs, effects from induced land development to Atlantic Sturgeon and critical habitat is expected to be immeasurable and therefore, insignificant.

Induced changes in land use may also result in changes of roadway runoff exposure within the Action Area portion of the critical habitat unit. Increased traffic volumes on the road networks traversing the watersheds could result in localized increases in roadway runoff contaminants attributable to the additional traffic. Conversely, decreases in traffic volume could have a potential localized beneficial effect by decreasing concentrations of toxicants originating from roadway runoff, and/or toxic spills along roadways. The purpose of the proposed project is to improve mobility, reduce forecast traffic congestion on the existing roadway network, and improve system linkage. Given that as mentioned in Section 4.4.2.2 the amount of increased runoff in the five pertinent subbasins is an immeasurable percentage of <1%, exposure to highway runoff could be redistributed locally in the critical habitat unit; however, the overall net increased exposure to roadway runoff is immeasurable (insignificant).

4.4.4 Conservation Measures to Avoid/Minimize Effects to Atlantic Sturgeon and Critical Habitat

NMFS and FHWA prepared the DPBE (NMFS 2017b) to streamline consultation and improve conservation for listed species and critical habitat under the purview of NMFS in North Carolina. While this project does not fall within the scope and criteria of the DPBE, the DPBE lists PDCs, which are non-discretionary measures that avoid or reduce the potential effects of permitted activities on listed species and critical habitat, that will be incorporated into Complete 540.

This BA used the DPBE as a guide to identify general and project specific PDCs. The BA identifies General PDCs that are applicable to all projects. These are standard measures implemented as part of environmental compliance that are intrinsically incorporated into this, and most, NCDOT projects. The General PDCs that are included in this project are noted in Appendix C.

The BA further discusses project specific PDCs that are evaluated in conjunction with the following ten regularly occurring transportation activities common to several project types:

1. Installation, maintenance, and removal of temporary erosion, turbidity, and sedimentation control devices

2. Staging areas
3. Site preparation
4. Geotechnical drilling and hazardous waste sampling
5. Installation, maintenance, and removal of scientific survey devices
6. Temporary platforms, access fills, and cofferdams
7. Pile installation and removal
8. Blasting
9. Dredging/underwater excavation
10. Equipment

All of these activities will be part of this project except for 5 (Installation, maintenance, and removal of scientific survey devices) and 9 (Dredging/underwater excavation). Activity 8 (Blasting), is not expected to occur within 50 feet of the Neuse River crossing. For the other activities, specific PDCs that will be incorporated into this project are provided in Appendix C.

In addition to the common project activities, the DPBE also considers specific project types, three of which are part of this project and detailed below:

1. New alignments/roadways and road widening (roadway construction)
2. New bridge, bridge replacement, and bridge widening; new and replacement piers
3. Installation, Maintenance, and Removal of Shoreline Stabilization

Project specific PDCs associated with each of these project types incorporated into the Complete 540 project are noted below. The numbers of each PDC (i.e., P1.3, P2.2, P5.1.4, etc) are consistent with the numbered recommendations in the DPBE (NMFS 2017b).

4.4.4.1 New Alignments/Roadways and Road Widening (Roadway Construction)

The Complete 540 project involves a new alignment/roadway. Project specific PDCs that will be part of this project at the Neuse River crossing are:

- The project is designed to not contribute sediments, toxicants, or pollutants into receiving waters where sturgeon occur.
- The project will use stormwater collection and treatment systems that discharge stormwater that meets or exceeds State Water Quality Standards into waters where sturgeon occur. Specifically, NCDOT is incorporating the Design Standards in Sensitive Watersheds [15A NCAC 04B .0124 (b) – (e)] throughout the project. The area within the Neuse watershed will be identified as “Environmentally Sensitive Areas” on the Sedimentation and Erosion Control Plans and subject to 15A NCAC 04B .0124. By definition, the Environmentally Sensitive Areas will be identified as a 50-foot (15.2-meter) buffer zone on both sides of the stream

measured from top of streambank. Within the identified 50-foot (15.2-meter) Environmentally Sensitive Areas, the following shall apply:

1. In areas identified as Environmentally Sensitive Areas, the Contractor may perform clearing operations, but not grubbing operations until immediately prior to beginning grading operations.
2. Once grading operations begin in identified Environmentally Sensitive Areas, work shall progress in a continuous manner until complete.
3. In areas identified as Environmentally Sensitive Areas, erosion control devices shall be installed immediately following the clearing operation.
4. In areas identified as Environmentally Sensitive Areas, “Seeding and Mulching” shall be performed on the areas disturbed by construction immediately following final grade establishment.
5. In areas identified as Environmentally Sensitive Areas, seeding and mulching shall be done in stages on cut and fill slopes that are greater than 20 feet (6.1 meters) in height measured along the slope, or greater than 2 acres (0.81 hectares) in area, whichever is less.
6. The riparian floodplain along the Neuse River will be revegetated in accordance with the details provided in Appendix D.

Critical Habitat specific PDCs:

- Based on current site assessment, the project alignment does not occur in an area with a concentration of PBFs. Additionally, PBFs within the FLUSA portion of the Action Area are not anticipated to be affected by the project.

4.4.4.2 New Bridge, Bridge Replacement, and Bridge Widening; New and Replacement Piers

Complete 540 project involves a new bridge over the Neuse River. Project specific PDCs were developed for this project that will be part of this project at the Neuse River crossing are:

- New Bridges
 - Shoreline stabilization for new bridges (approaches/causeway/embankment) will adhere to Shoreline Stabilization PDCs (Section 4.4.4.3).
- New Piers
 - New piers will not be installed where swimming sturgeon are known to occur.
 - New piers within 0.5 mile of areas where sturgeon are known to occur, or where Atlantic sturgeon critical habitat is present, will adhere to the following:
 - Take-off/causeway fill for piers will not be placed below the OHWM or MHWL of the waterbody or impede or restrict normal flows.
 - Shoreline stabilization activities for new or replacement piers (approaches/causeway/embankment) will adhere to Shoreline Stabilization PDCs (Section 4.4.4.3).

4.4.4.3 Installation, Maintenance, and Removal of Shoreline Stabilization

- Installation of new shoreline stabilization:

- Bank stabilization will not exceed 500 feet in length (for any type: e.g., seawalls, riprap, revetments).
- Riprap/Revetments
 - Shoreline stabilization materials will be free of debris and are limited to sand, cement, concrete, and quarry stone. No slope paving, poured concrete, or reinforced concrete will be utilized.

4.5 Summary of Conclusion of Effects-Atlantic Sturgeon & Critical Habitat

Various potential project related effects that were evaluated in this BA were described in Sections 4.1 through 4.3 and disclosed in Section 4.4. The conclusions of the analyses regarding the anticipated effects to Atlantic Sturgeon and critical habitat (DPS Carolina Unit 3) are summarized below.

4.5.1 Atlantic Sturgeon

As detailed in Section 3.2.3, the Neuse River Atlantic Sturgeon population numbers are very low compared to others in the Carolina DPSs. Furthermore, the absence of records of this species in the Action Area portion of the Neuse River, coupled with the generally shallow water depth in this section of the river suggest that the presence of the species within the Action Area is very low. However, since suitable spawning habitat occurs upstream of the project; approximately 2.8 river miles (4.5 kilometers) near Poole Road (Appendix B) and approximately 6.8 river miles (11 kilometers) at the former Milburnie Dam (RKM 328) (NMFS 2017a), NCDOT, as designated non-federal representative of the FHWA, recognizes that it cannot be definitively concluded that the species is absent from this portion of the river.

As concluded in Section 4.4, the likelihood of project related adverse effects (water quality, sedimentation, copper, nitrogen, noise, etc.) are unlikely to occur, or considered insignificant, or discountable. Additionally, since there will be no instream work during the August 15 – October 31 moratorium, project construction will not pose a barrier to migrating Atlantic Sturgeon. Considering the moratorium, minimal effect on water quality, the incorporation of the avoidance/minimization measures described in Section 4.4.4 and the assurances that passage of individual Atlantic Sturgeon will not be prohibited, coupled with the low probability that Atlantic Sturgeon use this section of the Neuse River, FHWA concludes the proposed action **“May Affect, Not Likely to Adversely Affect”** the Atlantic Sturgeon.

4.5.2 Critical Habitat

As detailed in Section 3.2.6.1, habitat in the Neuse River at the location of the proposed crossing is generally lacking the physical aspect (hard substrate) of the PBFs. However, as stated in the Final Rule for designating critical habitat for the Atlantic Sturgeon (NMFS 2017a), all PBFs do not need to be present in a stretch of the river for that stretch to be designated critical habitat.

Thus, we assessed the potential effects to the critical habitat unit in terms of each PBF applicable to this section of the Neuse River and to the overall functioning of the unit. The anticipated effects to Critical Habitat are considered to be either insignificant, or discountable and will not reach a level where the conservation values of the individual PBFs are compromised, nor will it eliminate the PBFs from the Neuse River.

The conclusion of effects to the applicable PBFs of the critical habitat unit are provided individually.

1) Hard bottom substrate (e.g., rock, cobble, gravel, limestone, boulder, etc.) in low salinity waters (i.e., 0.0-0.5 parts per thousand range) for settlement of fertilized eggs and refuge, growth, and development of early life stages.

The hard bottom substrate component is generally absent from the proposed crossing location of the river. These features are present at various locations in the overall Action Area; however, project construction will not limit migrating Atlantic Sturgeon from accessing these features upstream of the crossing, and project related sedimentation is considered to be insignificant and not to the level where it would diminish the conservation value of any of those features downstream of the proposed crossing.

(2) Transitional salinity zones inclusive of waters with a gradual downstream gradient of 0.5 up to as high as 30 parts per thousand and soft substrate (e.g., sand, mud) between the river mouth and spawning sites for juvenile foraging and physiological development:

The entire portion of the Neuse River within the Action Area is considered freshwater, and well upstream of the salt water wedge. Project construction will have no effect on the salinity regime in this portion of the river, and will not affect the downstream salinity transition of the river.

(3) Water of appropriate depth and absent physical barriers to passage (e.g., locks, dams, thermal plumes, turbidity, sound, reservoirs, gear, etc.) between the river mouth and spawning sites necessary to support (i) Unimpeded movement of adults to and from spawning sites, (ii) Seasonal and physiologically dependent movement of juvenile Atlantic Sturgeon to appropriate salinity zones within the river estuary; and (iii) Staging, resting, or holding of subadults or spawning condition adults. Water depths in main river channels must also be deep enough (at least 1.2 meters) to ensure continuous flow in the main channel at all times when any sturgeon life stage would be in the river.

While the majority of the channel in the Neuse River within the Action Area is less than 1.2 meters, as described in Section 3.2.6.1, the thalweg is at least this deep during base flow. Potentially suitable spawning habitat has been identified upstream of the proposed crossing; however, as previously stated, in Section 4.4.1.1, the bridge design, causeway placement, and

use of turbidity curtains will not create a physical barrier, as sufficient passage will be maintained during construction. The design of the bridge is not anticipated to result in any measurable effect on water depths within this portion of the river. While the placement of the causeways will have a temporary effect on water depth (deeper upstream, shallower downstream), these effects will be minimized by placing pipes within the causeways, are localized, and will not affect the overall depth of the river in this area since sufficient passage will be maintained within a portion of the river at all times during construction. In addition, sedimentation effects are not anticipated to reach a level that would create a depth barrier, and the implementation of the construction moratorium will ensure there is no noise barrier to migrating individuals in the event they are present in the river.

(4) Water quality conditions, especially in the bottom meter of the water column, with temperature and oxygen values that support (i) Spawning; (ii) Annual and inter-annual adult, subadult, larval, and juvenile survival; and (iii) Larval, juvenile, and subadult growth, development, and recruitment.

As concluded in Section 4.4.3 project related effects on the modeled water quality parameters (TSS, Nitrogen and Copper) are anticipated to be insignificant.

As summarized above the anticipated effects to the essential physical features of the critical habitat unit are either unlikely to occur (discountable), or are insignificant. Therefore, FHWA concludes that the proposed action “**May Affect, Not Likely to Adversely Affect**” critical habitat of the Atlantic Sturgeon.

4.5.3 Determination of Effects

As stated previously, FHWA initiated formal consultation with the USFWS on the federally listed species noted in Table 1 on December 6, 2017 in a separate BA. Given the very low probability of Atlantic Sturgeon to occur within the action area, the projected insignificant and/or discountable effects to the PBFs within the critical habitat unit, and the implementation of avoidance and minimization measures, FHWA has determined that the Complete 540 project “**May Affect, Not Likely to Adversely Affect**” the Atlantic Sturgeon. FHWA has also determined that the Complete 540 project “**May Affect, Not Likely to Adversely Affect**” critical habitat of the Atlantic Sturgeon.

5.0 LITERATURE CITED

- Atlantic Sturgeon Status Review Team (ASSRT). 2007. *Status Review of Atlantic Sturgeon (Acipenser oxyrinus oxyrinus)*. Report to National Marine Fisheries Service, Northeast Regional Office. February 23, 2007. 174 pp.
- Atlantic States Marine Fisheries Commission (ASMFC). 1998. American shad and Atlantic sturgeon stock assessment peer review: Terms of reference and advisory report. Atlantic States Marine Fisheries Commission, Washington D.C.
- ASMFC. 2007. Special Report to the Atlantic Sturgeon Management Board: Estimation of Atlantic sturgeon bycatch in coastal Atlantic commercial fisheries of New England and the Mid-Atlantic.
- Bain, M.B. 1997. Atlantic and shortnose sturgeons of the Hudson River: common and Divergent life history attributes. *Env. Biol. Fish.* 48: 347-358.
- Baker Engineering. 2017a. Quantitative ICE Assessment Memo #1. November 2017.
- Baker Engineering. 2017b. Quantitative ICE Assessment Memo #2. November 2017.
- Baker Engineering. 2017c. Memorandum on Water Quality Modeling Methodology and Results. (Quantitative ICE Assessment Memo #3). November 2017.
- Baker Engineering. 2017d. Indirect and Cumulative Effects Memorandum. (Quantitative ICE Assessment Memo #4). November 2017.
- Beasley, C. A., and J. E. Hightower. 2000. Effects of a low-head dam on the distribution and characteristics of spawning habitat used by striped bass and American shad. *Transactions of the American Fisheries Society* 129:1372-1386.
- Belovsky, G. E. 1987. Extinction models and mammalian persistence. Chapter 3 In: Soulé, M.E. (ed), *Viable Populations for Conservation*. Cambridge University Press, pp.35-57.
- Boreman, J. 1997. Sensitivity of North American sturgeons and paddlefish to fishing mortality. *Environmental Biology of Fishes* 48:399-405.
- Bowman, S., and J.E. Hightower. 2001. American shad and striped bass spawning migration and habitat selection in the Neuse River, North Carolina. Final Report to the North Carolina Marine Fisheries Commission. 63 pp.
- Caltrans Office of Environmental Engineering 2001. Fisheries Impact Assessment Pre Installation Demonstration Project for the San Francisco-Oakland Bay Bridge East Span Seismic Safety Project.” Caltrans Contract 04A0148.

- Castro, J. 2003. Geomorphologic Impacts of Culvert Replacement and Removal: Avoiding Channel incision. Oregon Fish and Wildlife Office, Portland, OR February 2003 Guidelines – Version 2.0, 19 pp.
- Chytalo, K. 1996. Summary of Long Island Sound dredging windows strategy workshop. Management of Atlantic Coastal Marine Fish Habitat: Proceedings of a workshop for habitat managers. ASMFC Habitat Management Series #2.
- Dwyer, F. J., D. K. Hardesty, C. G. Ingersoll, J. L. Kunz, and D. W. Whites. 2000. Assessing contaminant sensitivity of American shad, Atlantic sturgeon and shortnose sturgeon. Final Report to New York Department of Environmental Conservation, Albany, NY.
- Federal Highway Administration (FHWA). 2014. U.S. Route 17 Widening and Bridge Over Back River. Biological Assessment for the Atlantic and Shortnose Sturgeons and West Indian Manatee. Jasper County, South Carolina and Chatham County, Georgia. June 2014.
- GWC. 2006. Georgia Water Coalition. Interbasin Transfer Fact Sheet. <http://www.garivers.org/gawater/pdf%20files/IBT%20fact%20sheet02-06.pdf>.
- H.W Lochner, Inc. 2014. Indirect and Cumulative Effects Report for Administrative Action Environmental Impact Statement, STIP Project Nos. R-2721, R-2828, and R-2829. December 2014, 167 pp.
- Hassler, W.W., and N.L. Hill. 1974. A sport and commercial fisheries survey of the lower Neuse River, North Carolina. North Carolina State University. 111 pp.
- Hoff, J. G. 1980. Review of the present status of the stocks of the Atlantic sturgeon *Acipenser oxyrinchus*, Mitchill. Prepared for the National Marine Fisheries Service, Northeast Region, Gloucester, Massachusetts.
- Holland, B. F., and G. F. Yelverton. 1973. Distribution and biological studies of anadromous fishes offshore North Carolina. N. C. Dep. Nat. Econ. Resour. Spec. Rep. No. 24. 132 pp.
- IPCC. 2008. Climate Change and Water, Technical Paper of the Intergovernmental Panel on Climate Change, IPCC Secretariat, Geneva, 210 pp. Kays, Barrat L. 2002. Turbidity in Construction Runoff. New Technology Addresses Murky Problem. July 2002. <http://www.landispllc.com/assets/Uploads/publications/7.pdf>
- Miller, T., and G. Shepherd. 2011. Summary of Discard Estimates for Atlantic Sturgeon. Population Dynamics Branch, Northeast Fisheries Science Center.
- National Marine Fisheries Service (NMFS). 1998. Final Recovery Plan for the Shortnose Sturgeon (*Acipenser brevirostrum*). National Oceanic and Atmospheric Administration, National Marine Fisheries Service, Silver Spring, Maryland. December 1998.

- National Marine Fisheries Service (NMFS). 2012. Endangered and Threatened Wildlife and Plants; Final Listing Determinations for Two Distinct Population Segments of Atlantic Sturgeon (*Acipenser oxyrinchus oxyrinchus*) in the Southeast, Federal Register 77(24):5914-5982.
- National Marine Fisheries Service (NMFS). 2017a. Endangered and Threatened Species; Designation of Critical Habitat for the Endangered New York Bight, Chesapeake Bay, Carolina and South Atlantic Distinct Population Segments of Atlantic Sturgeon and the Threatened Gulf of Maine Distinct Population Segment of Atlantic Sturgeon. Federal Register [50 CFR Part 226, Vol. 82, No. 158, Thursday, August 17/ Rules and Regulations.
- National Marine Fisheries Service (NMFS). 2017b. Draft Programmatic Biological Evaluation (DPBE) (NLAA) on the Effects of Transportation Activities and Projects Undertaken in North Carolina, South Carolina, and Georgia. In Collaboration with Federal Highway Administration. August 2017.
- Niklitschek, E. J., and D. H. Secor. 2005. Modeling spatial and temporal variation of suitable nursery habitats for Atlantic sturgeon in the Chesapeake Bay. *Estuarine, Coastal and Shelf Science* 64:135-148.
- Niklitschek, E. J., and D. H. Secor. 2009a. Dissolved oxygen, temperature and salinity effects on the ecophysiology and survival of juvenile Atlantic sturgeon in estuarine waters: I. Laboratory results. *Journal of Experimental Marine Biology and Ecology* 381(Supplement 1): S150-S160.
- Niklitschek, E. J., and D. H. Secor. 2009b. Dissolved oxygen, temperature and salinity effects on the ecophysiology and survival of juvenile Atlantic sturgeon in estuarine waters: II. Model development and testing. *Journal of Experimental Marine Biology and Ecology* 381(Supplement 1): S161-S172.
- Niklitschek, E. J., and D. H. Secor. 2010. Experimental and field evidence of behavioral habitat selection by juvenile Atlantic *Acipenser oxyrinchus oxyrinchus* and shortnose *Acipenser brevirostrum* sturgeons. *Journal of Fish Biology* 77:1293-1308.
- North Carolina Department of Environment and Natural Resources (NCDENR). 2015. North Carolina Natural Heritage Program 2015 Biennial Report, Biennial Protection Plan, List of Natural Areas, Department of Environment and Natural Resources, Office of Land and Water Stewardship, Raleigh.
- North Carolina Department of Environmental Quality (NCDEQ). 2017a. 303(d) Files. Accessed July 10, 2017. <https://deq.nc.gov/about/divisions/water-resources/planning/classification-standards/303d/303d-files>

- North Carolina Department of Environmental Quality (NCDEQ). 2017b. NPDES Permitting - Permitting Process. Accessed June 12, 2017. <https://deq.nc.gov/about/divisions/water-resources/water-quality-permitting/npdes-wastewater/npdes-permitting>
- North Carolina Natural Heritage (NCNHP). 2017. Natural Heritage Natural Area Tier 2 polygon shapefile. October 2017 version.
- Oakley, N. C. 2003. Status of shortnose sturgeon, *Acipenser brevirostrum*, in the Neuse River, North Carolina. Thesis. Department of Fisheries and Wildlife Science, North Carolina State University, Raleigh, NC.
- Pyzik, L., J. Caddick, and P. Marx. 2004. Chesapeake Bay: Introduction to an ecosystem. EPA 903-R-04-003, CBP/TRS 232100.
- Restorations Systems, LLC. 2016. Milburnie Dam Mitigation Bank: Mitigation Banking Instrument and Exhibits, Agreement to Establish the Milburnie Dam Mitigation Bank in Wake County, North Carolina. Agreement entered in June 2016 between Restoration Systems, LLC. And the Interagency Review Team.
- Rohde, F. C., R. G. Arndt, J. W. Foltz and J. M. Quattro. 2009. *Freshwater Fishes of South Carolina*. University of South Carolina Press, Columbia, South Carolina.
- Rosgen, D. 1996. Applied River Morphology. Pagosa Springs, CO, Wildland Hydrology Books, 1481 Stevens Lake Road, Pagosa Springs CO. 81147, 385 pp.
- Salwasser, H., S. P. Mealey, and K. Johnson. 1984. Wildlife population viability: a question of risk. Pages 421-439 in Transactions of the North American Wildlife and Natural Resources Conference.
- Secor, D. 1995. Chesapeake Bay Atlantic sturgeon: current status and future recovery. Summary of findings and recommendations from a workshop convened 8 November 1994 at Chesapeake Biological Laboratory. Chesapeake Bay Biological Laboratory, Center for Estuarine and Environmental Studies, University of Maryland System, Solomons, MD.
- Secor, D. H., and T. E. Gunderson. 1998. Effects of hypoxia and temperature on survival, growth, and respiration of juvenile Atlantic sturgeon (*Acipenser oxyrinchus*). Fishery Bulletin U.S. 96:603-613.
- Smith, T. I. J., and J. P. Clugston. 1997. Status and management of Atlantic sturgeon, *Acipenser oxyrinchus*, in North America. Environmental Biology of Fishes 48:335-346.
- Smith, T. I. J., E. K. Dingley, and E. E. Marchette. 1980. Induced spawning and culture of Atlantic sturgeon. Progressive Fish Culturist 42:147-151.
- Soulé, M. E. 1987. Where do we go from here? Chapter 10 In: Soulé, M.E. (ed), Viable Populations for Conservation. Cambridge University Press, pp.175-183.

- Stein, A. B., K. D. Friedland, and M. Sutherland. 2004. Atlantic Sturgeon Marine Bycatch and Mortality on the Continental Shelf of the Northeast United States. *North American Journal of Fisheries Management* 24:171-183.
- Thomas, C. D. 1990. What Do Real Population Dynamics Tell Us About Minimum Viable Population Sizes? *Conservation Biology* 4:324-327.
- Thompson, D.B., A. Morse, J. Acker. 2011. Analysis of the Occurrence and Statistics of Hazardous Materials Spill Incidents along Texas Highways and Suggestions for Mitigation of Transport-Related Spills to Receiving Waters. Center for Multidisciplinary Research in Transportation. Department of Civil and Environmental Engineering. Texas Tech University. June 2011.
- USGRG. 2004. U.S. National Assessment of the Potential Consequences of Climate Variability and Change, Regional Paper: The Southeast. U.S. Global Research Group. Washington, D.C., August 20, 2004.
- Vladykov, V. D. and J. R. Greely. 1963. Order Acipenseroidei. In: *Fishes of Western North Atlantic*. Sears Foundation. Marine Research, Yale Univ. 1 630 pp.
- Winger, P. V., P. J. Lasier, D. H. White, and J. T. Seginak. 2000. Effects of Contaminants in Dredge Material from the Lower Savannah River. *Archives of Environmental Contamination and Toxicology* 38:128-136.
- Wooley, C., 1985. Evaluation of morphometric characters used in taxonomic separation of Gulf of Mexico sturgeon, *Acipenser oxyrinchus desotoi*. Pages 97-103 in Frederick P. Binkowski and Sergei I. Doroshov, editors. *North American sturgeons: biology and aquaculture potential*. Dr. W. Junk publishers, Boston, MA.
- Yelverton, John T., Donald R. Richmond, William Hicks, Keith Saunders, and Royce Fletcher. 1975. The relationship between fish size and their response to underwater blast. Lovelace Foundation for Medical Education and Research, Albuquerque, NM.

Appendix A

Figures

Biological Assessment - Atlantic Sturgeon

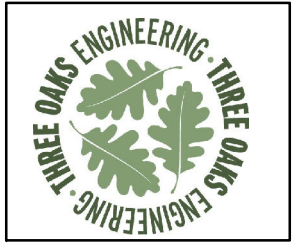
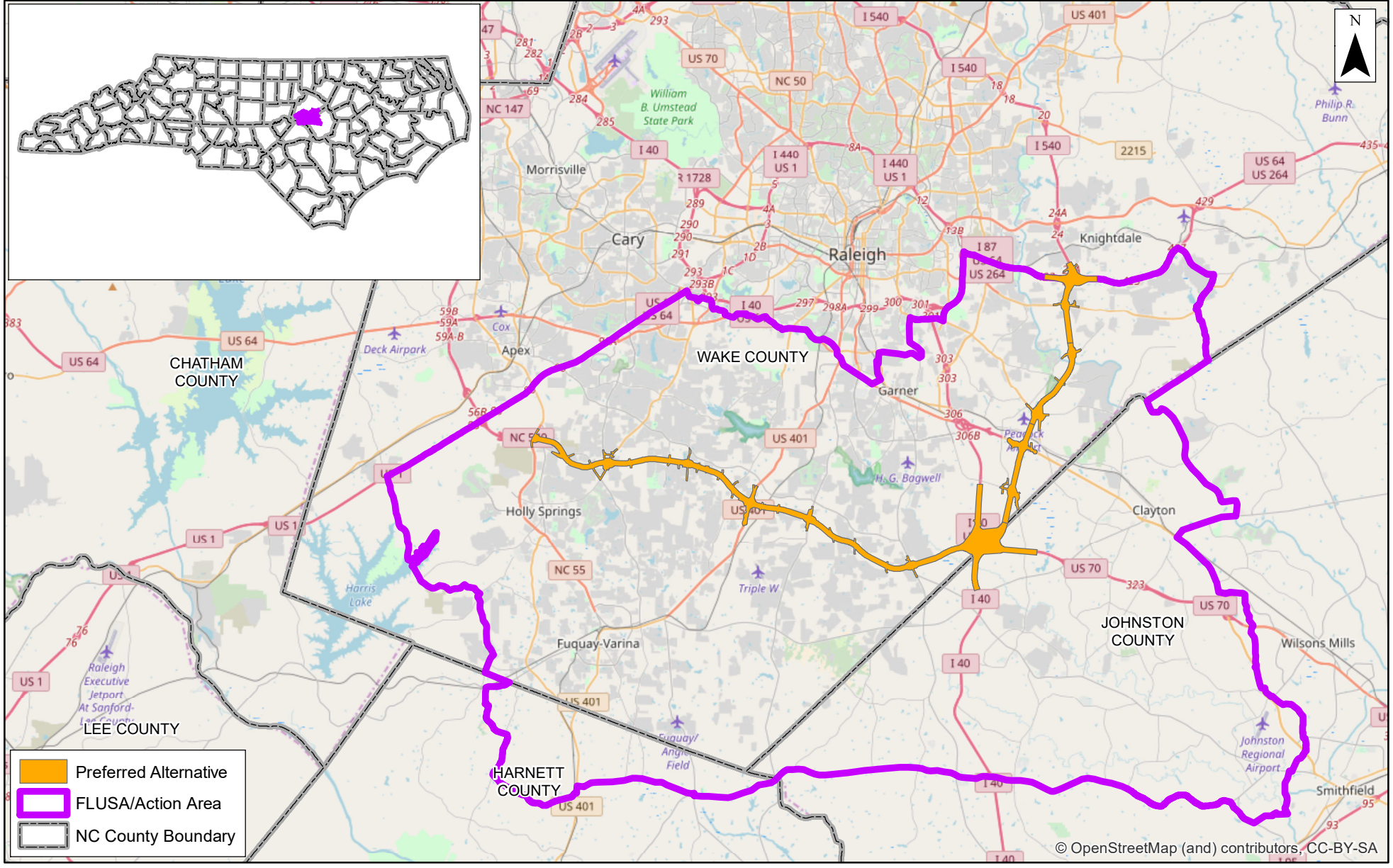

Prepared For:

STATE OF NORTH CAROLINA
DEPARTMENT OF TRANSPORTATION

**Complete 540 Triangle Expressway
Southeast Extension**

Future Land Use Study Area (FLUSA) / Action Area
and Preferred Alternative

Wake, Johnston, & Harnett Counties, North Carolina

Date: December 2017	
Scale: 0 1.5 3 Miles	
Job No.: 17-120	
Drawn By: NMS	Checked By: KMS

Figure
1

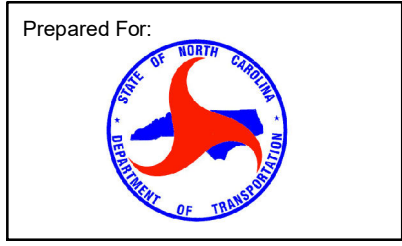
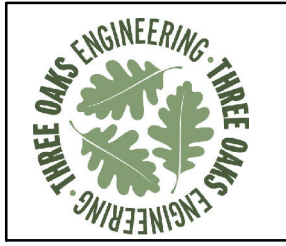
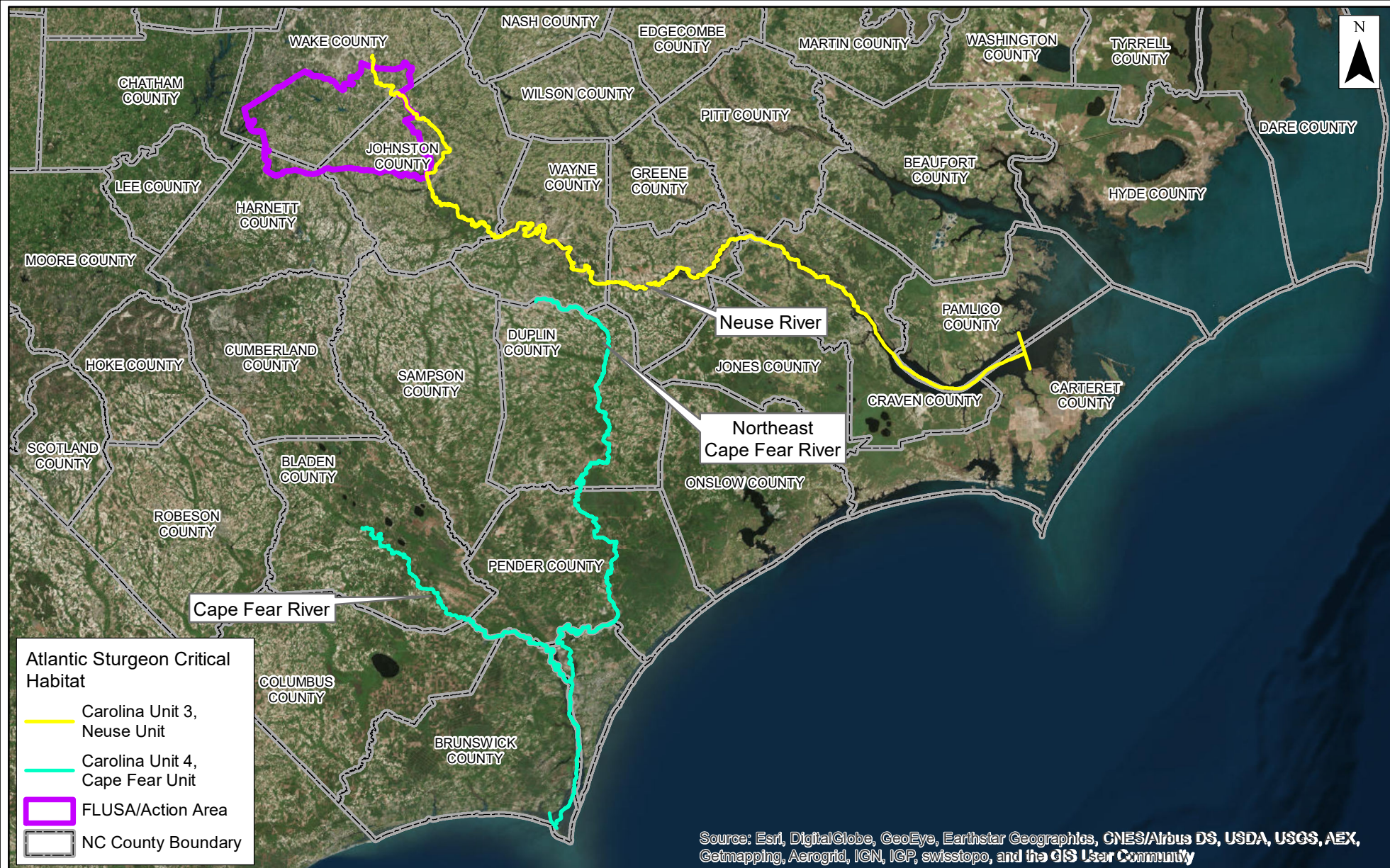

**Complete 540 Triangle Expressway
 Southeast Extension**
 FLUSA/Action Area and
 Atlantic Sturgeon Critical Habitat Units
 Eastern North Carolina

Date:	December 2017
Scale:	0 5 10 Miles
Job No.:	17-120
Drawn By:	NMS
Checked By:	KMS

Figure
2

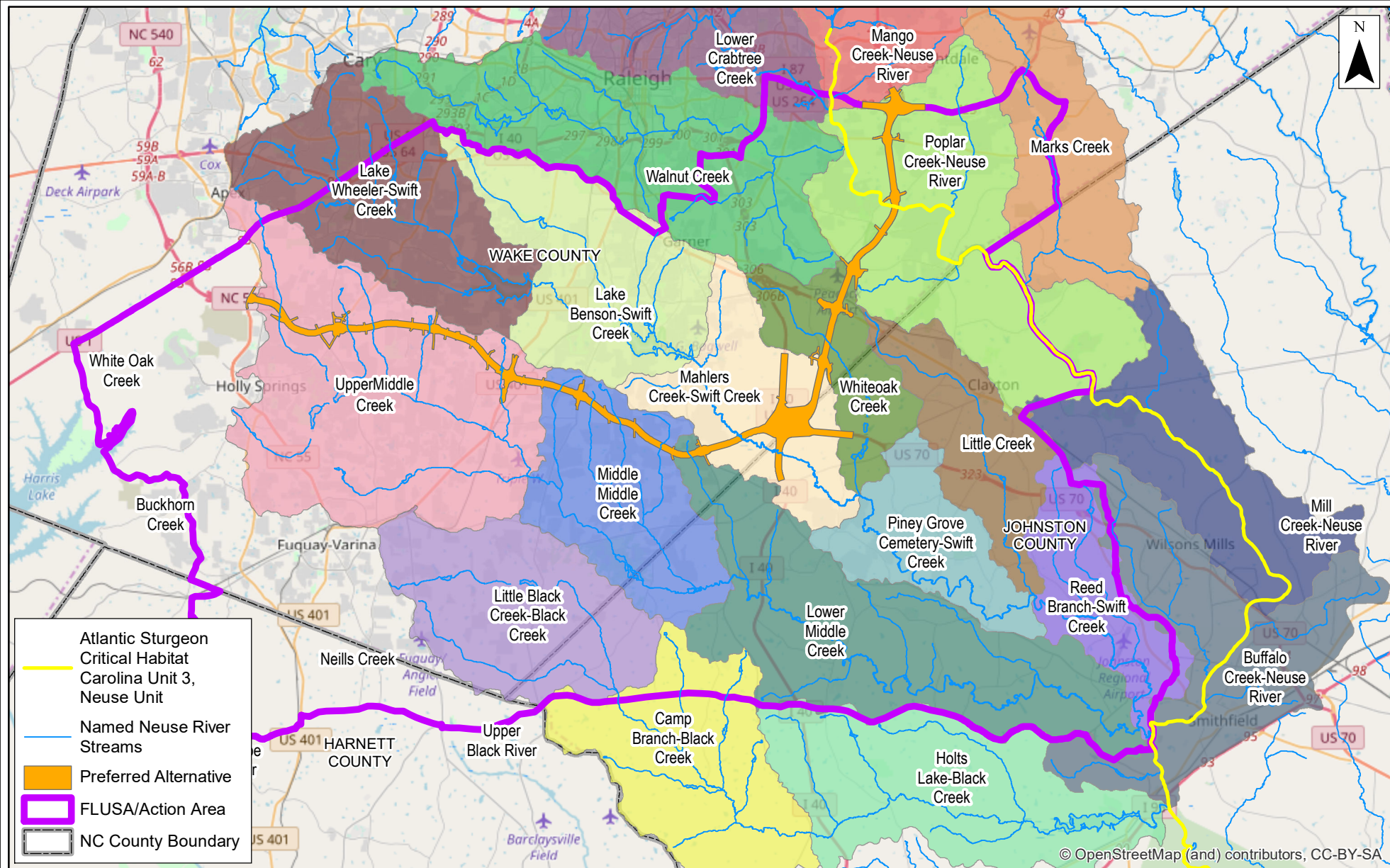

© OpenStreetMap (and) contributors, CC-BY-SA

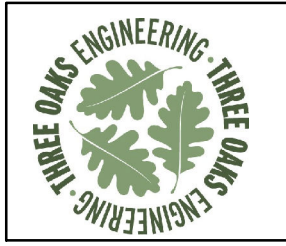

Prepared For:

**Complete 540 Triangle Expressway
Southeast Extension**

 Neuse River Subbasins

 Wake & Johnston Counties, North Carolina

Date:	December 2017
Scale:	0 1 2 Miles
Job No.:	17-120
Drawn By:	NMS
Checked By:	KMS

Figure

3

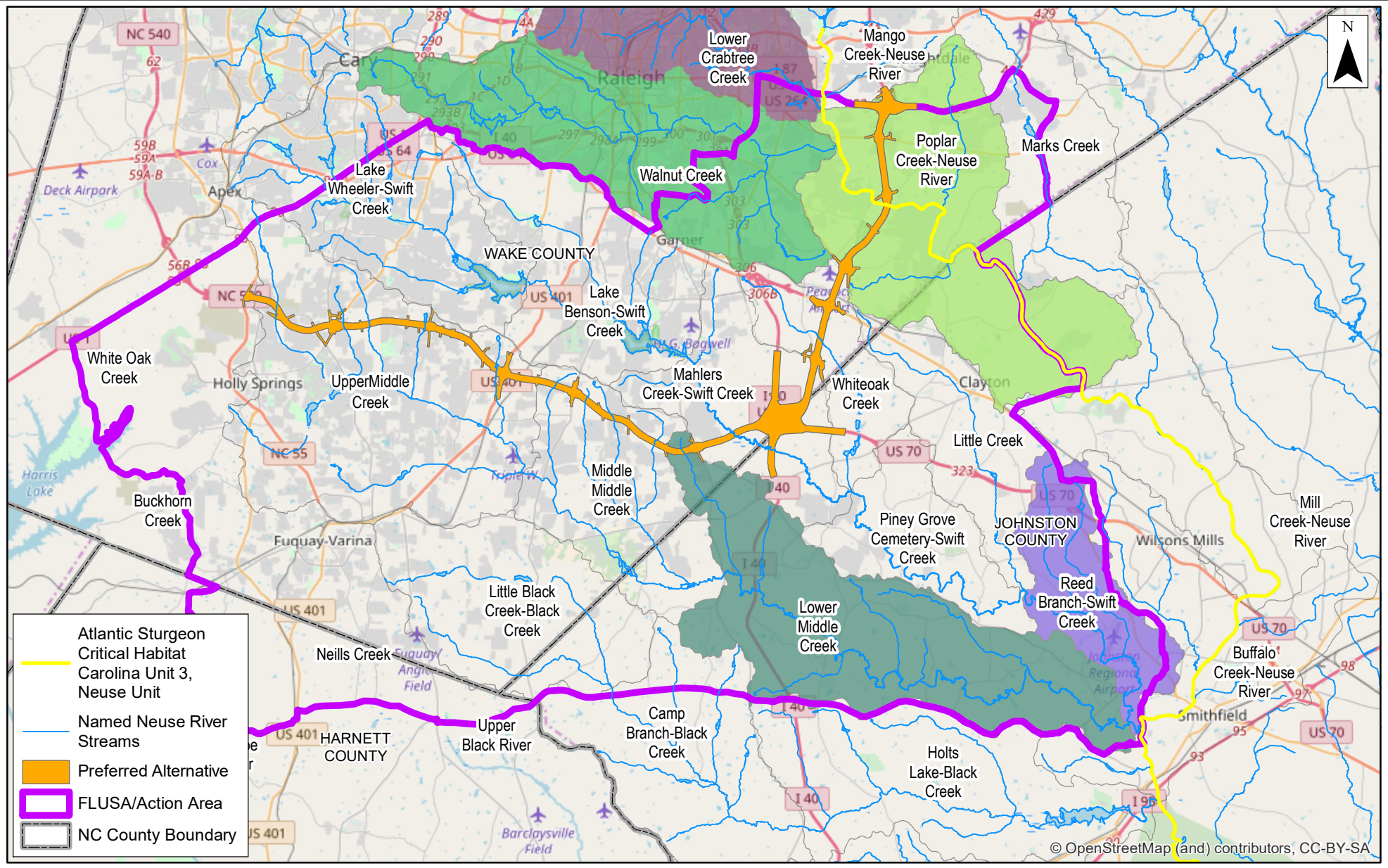

Prepared For:



Complete 540 Triangle Expressway Southeast Extension

Pertinent FLUSA Subbasins

Wake & Johnston Counties, North Carolina

Date:

December 2017

Scale:

0 1 2 Miles

Job No.:

17-120

Drawn By:

NMS

Checked By:

KMS

Figure

4

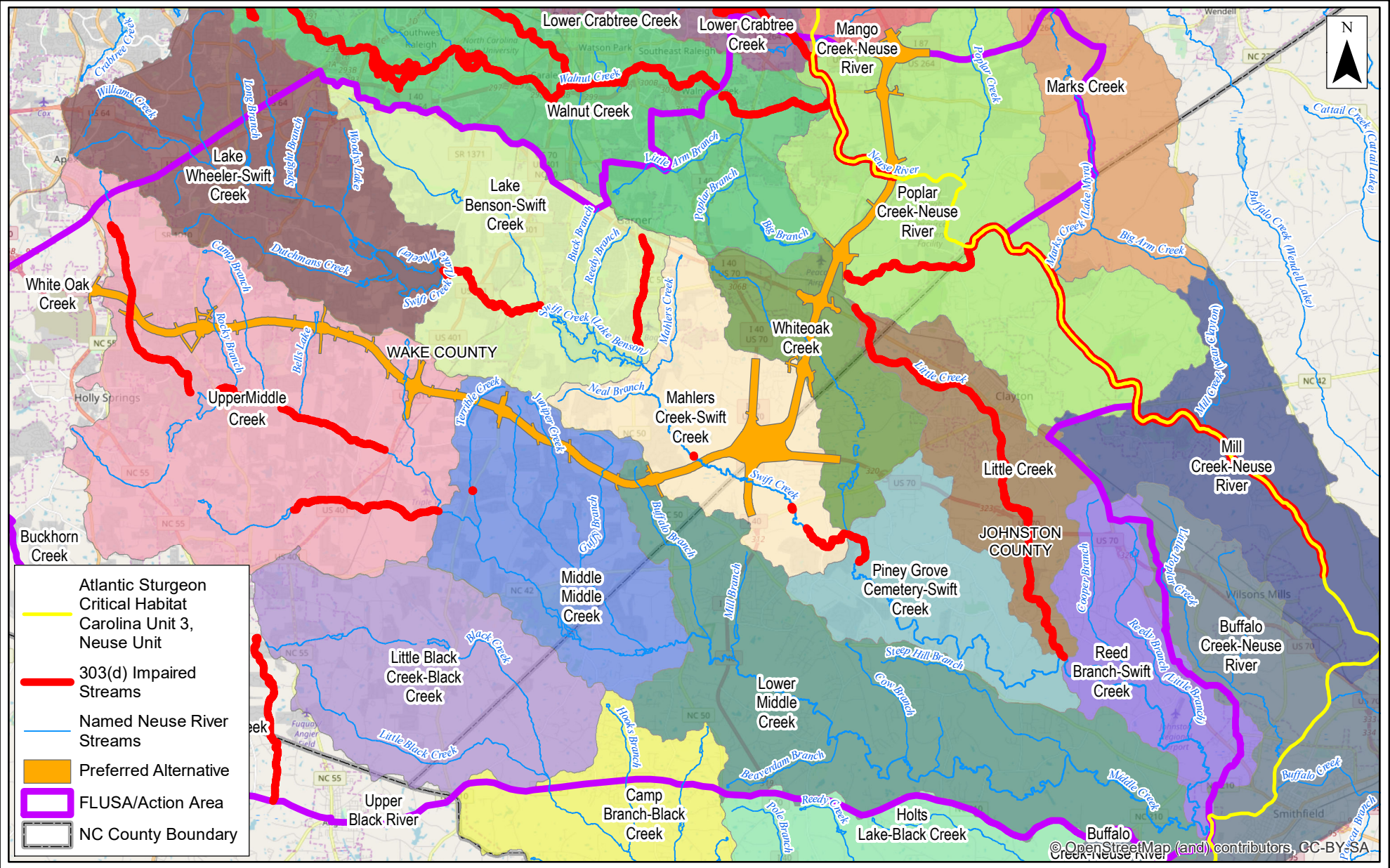

Prepared For:



Complete 540 Triangle Expressway Southeast Extension

North Carolina Department of Environmental Quality
303(d) Impaired Streams

Wake & Johnston Counties, North Carolina

Date:
December 2017

Scale:
0 1 2 Miles

Job No.:
17-120

Drawn By: NMS
Checked By: KMS

Figure

5

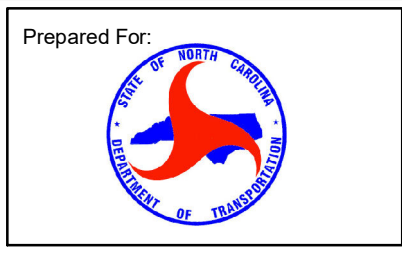
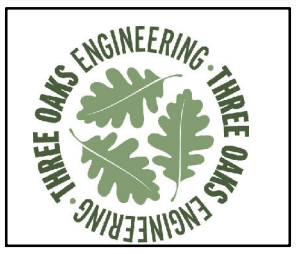
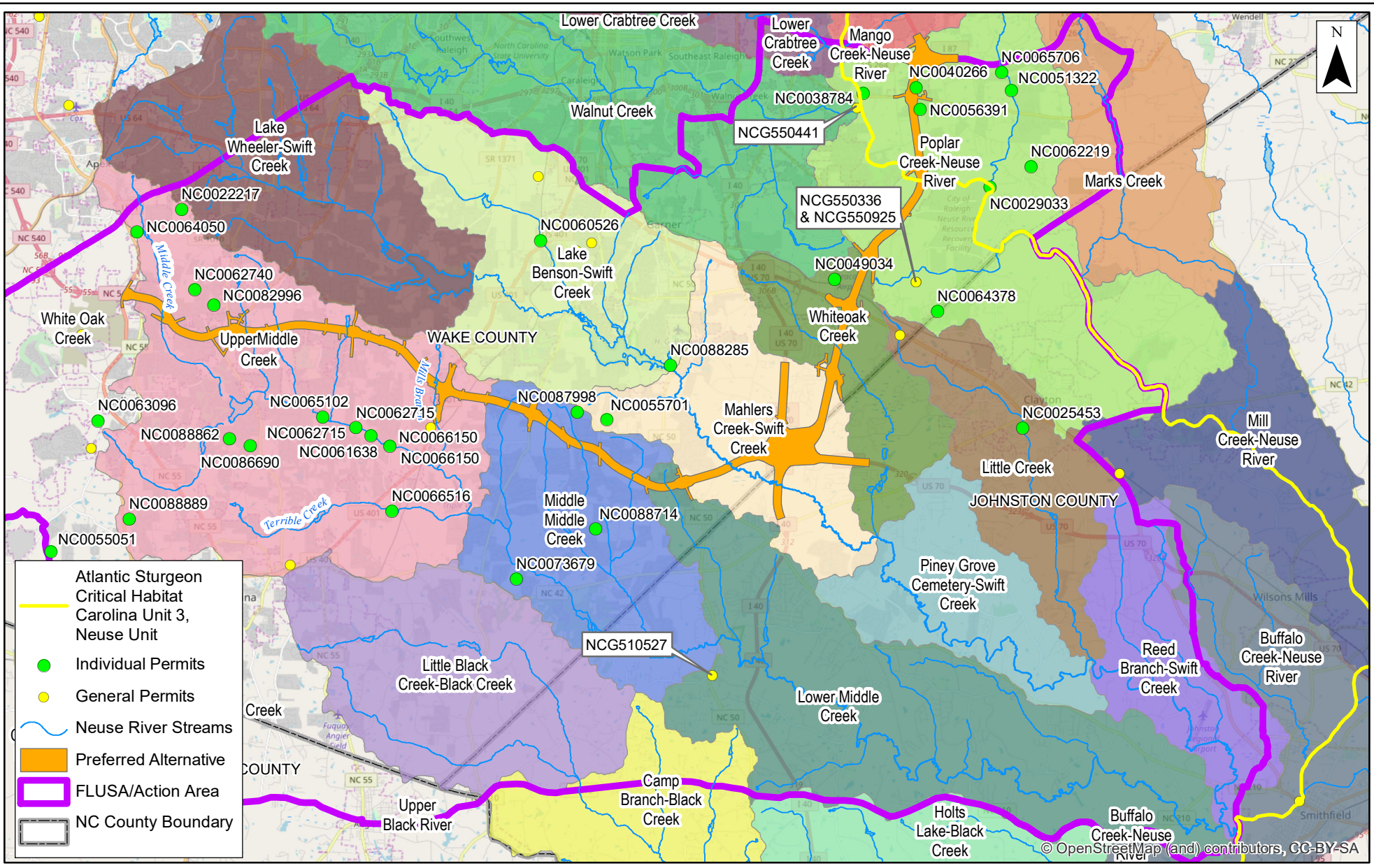

**Complete 540 Triangle Expressway
Southeast Extension**







 National Pollutant Discharge
Elimination System Discharge Permits

 Wake & Johnston Counties, North Carolina

Date:	December 2017
Scale:	0 1 2 Miles
Job No.:	17-120
Drawn By:	NMS
Checked By:	KMS

Figure

6

-  Atlantic Sturgeon Critical Habitat Carolina Unit 3, Neuse Unit
-  Habitat Characterization Transects
-  Approximate Bridge Crossing Location
-  Clay
-  Coarse sand
-  Coarse sand and small gravel
-  Dry Sand bar



NC911, NCCGIA

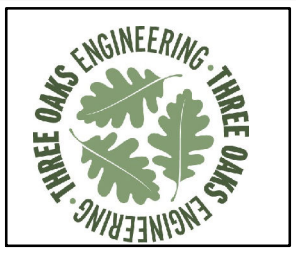

Prepared For:

**Complete 540 Triangle Expressway
Southeast Extension**

 Project Crossing of Neuse River

 Wake County, North Carolina

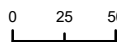
Date:		December 2017	
Scale:			
Job No.:		17-120	
Drawn By:	Checked By:	NMS	KMS

Figure

8

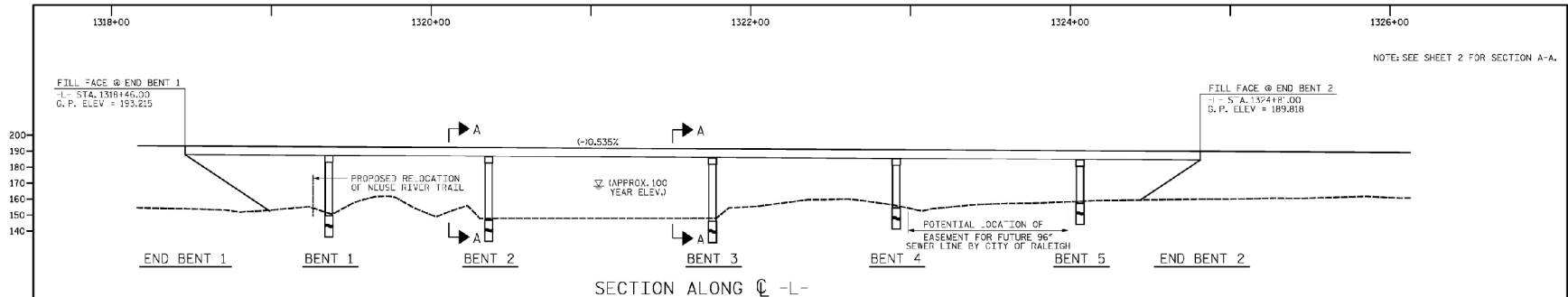

**DIMENSIONS ARE MEASURED ALONG ARC

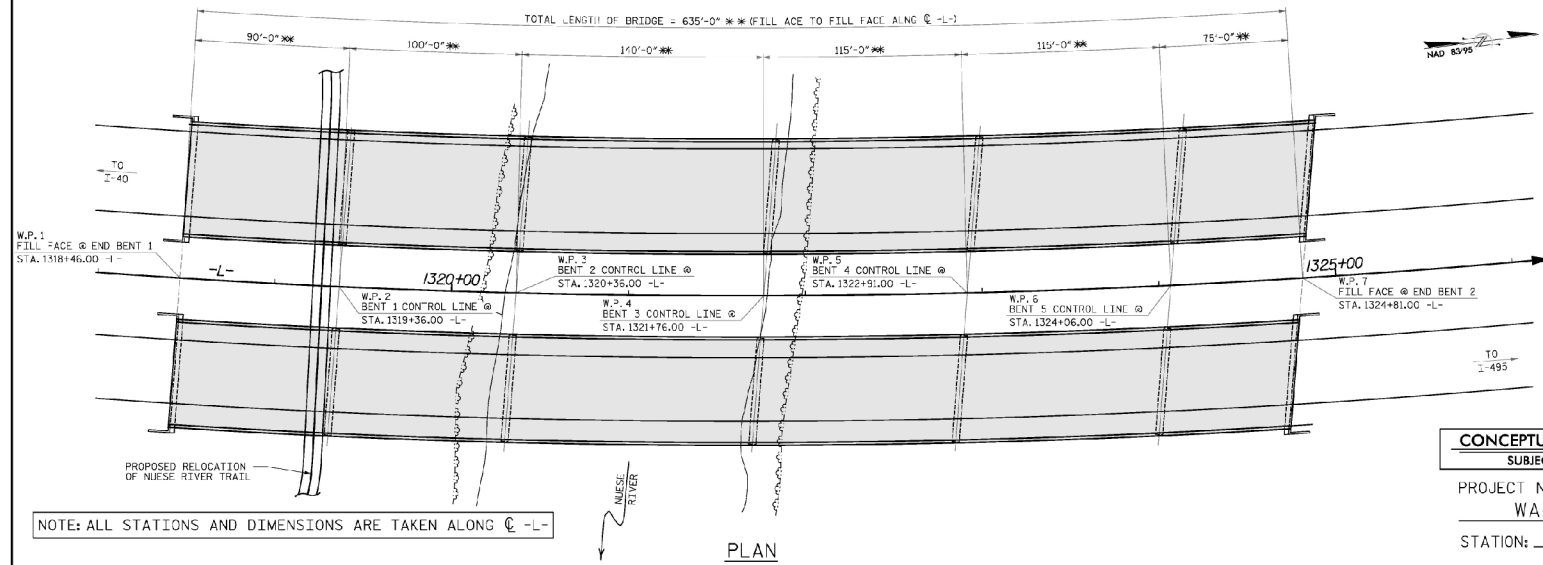

NOTE: ALL STATIONS AND DIMENSIONS ARE TAKEN ALONG C-L-

CONCEPTUAL LAYOUT ONLY
 SUBJECT TO CHANGE
 PROJECT NO. R-2829
 WAKE COUNTY
 STATION: _____

STATE OF NORTH CAROLINA
 DEPARTMENT OF TRANSPORTATION
 RALPH

COMPLETE 540
 CONCEPTUAL LAYOUT
 FOR BRIDGE OVER
 NEUSE RIVER

REVISIONS				SHEET NO.	
NO.	DATE	BY	DATE	NO.	DATE
1				1	
2				2	

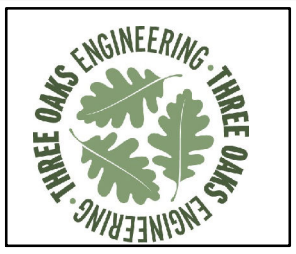

Prepared For:

Complete 540 Triangle Expressway
Southeast Extension
 Conceptual Layout for Bridge
 over Neuse River
 Wake County, North Carolina

Date:	December 2017
Scale:	
Job No.:	17-120
Drawn By:	NMS
Checked By:	KMS

Figure
9

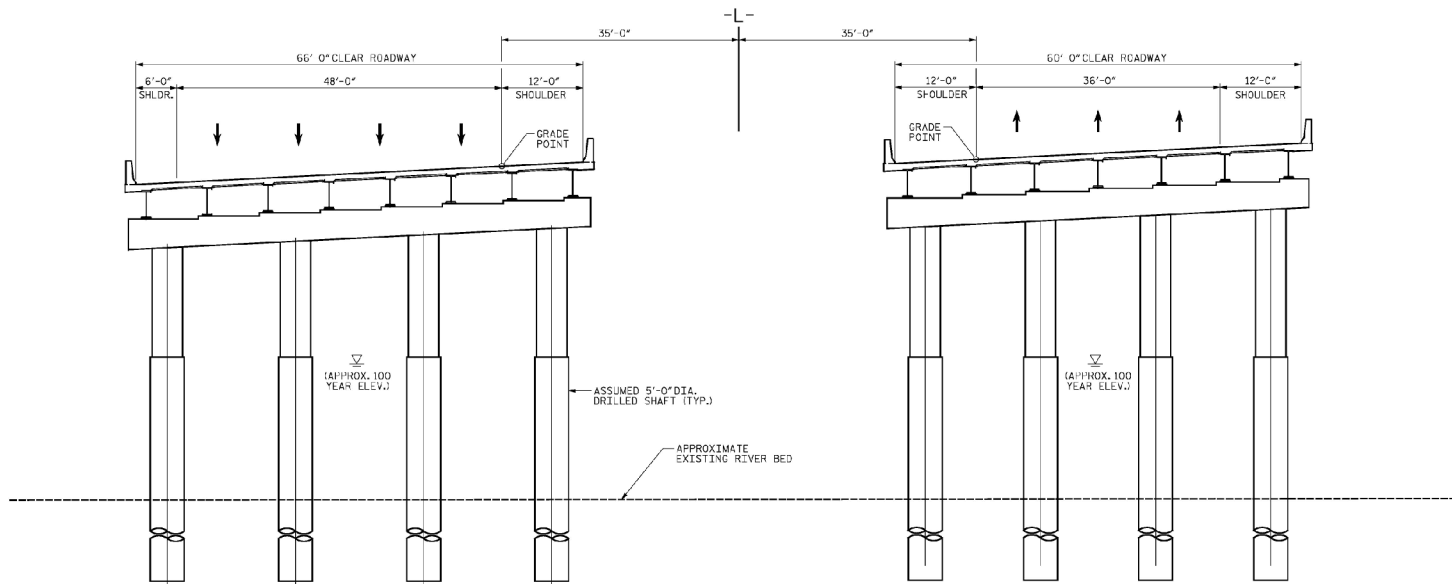

SECTION A-A
(at Bent's in Neuse River)

CONCEPTUAL LAYOUT ONLY
SUBJECT TO CHANGE

PROJECT NO. R-2829
WAKE COUNTY
STATION: _____

STATE OF NORTH CAROLINA
DEPARTMENT OF TRANSPORTATION
RALEIGH
COMPLETE 540
CONCEPTUAL TYPICAL
SECTION FOR BRIDGE
OVER NEUSE RIVER

REVISIONS						SHEET NO.
NO.	BY:	DATE:	NO.	BY:	DATE:	TOTAL SHEETS
1			1			2
2			2			2

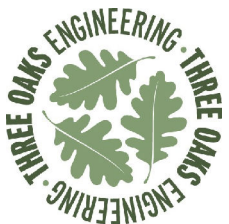

Prepared For:



Complete 540 Triangle Expressway Southeast Extension

Conceptual Typical for Bridge
over Neuse River

Wake County, North Carolina

Date: December 2017

Scale:

Job No.: 17-120

Drawn By:
NMS

Checked By:
KMS

Figure

10

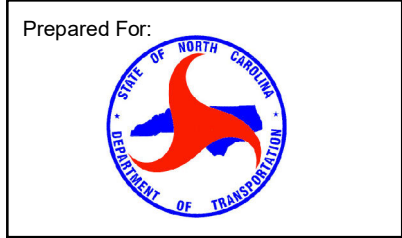
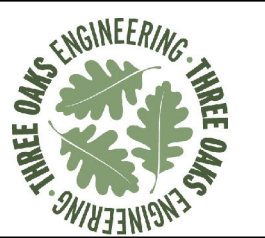

**Complete 540 Triangle Expressway
Southeast Extension**

Project Crossing of Neuse River
In Relation to Auburn-Knightdale Road Bridge

Wake County, North Carolina

Date:	December 2017
Scale:	0 100 200 Feet
Job No.:	17-120
Drawn By:	NMS
Checked By:	KMS

Figure
11

Appendix B

Site Assessment

Biological Assessment - Atlantic Sturgeon

The proposed project crossing location of the Neuse River occurs at approximately RKM 338. The general substrate in the Johnston County and eastern Wake County section of the Neuse River is dominated by shifting sand and soft clay banks, with sporadic pockets of gravel, cobble, boulder and bedrock. The specific physical habitat conditions within the project footprint were qualitatively evaluated on November 17, 2017 by wading and recording substrate composition and water depth along cross river transects of the centerline and upstream and downstream limits of the proposed crossing. Water depth and substrate composition were recorded across the channel from the right descending bank (RDB) to left descending bank (LDB) and recorded in distance intervals (feet) as conditions changed. The river was running between 231-264 cubic feet per second (cfs) on this date, which is below the 35-year mean of 340 cfs at the closest USGS streamflow gage (USGS 02087500) near Clayton, approximately 10 river miles downstream. Gage height during this time was 1.35 feet. The distance from the water surface to the top of the respective banks (TOB) was estimated.

In general, the water depth in most of the crossing location is six inches or less, and there is a large mid-channel sand bar that is exposed during base flow. The deepest sections of the river occur adjacent to both banks, with maximum water depths of 2.5 feet along the right descending bank and 4.5 feet on the left descending bank. These deeper thalweg areas are narrow (<25 feet in length).

Other than a very minor (approximately 1-5%) small gravel component in limited areas, there was no concentration of any hard substrate (gravel, cobble, etc.), which are identified as Physical and Biological Features (PBFs) essential to the conservation of the Atlantic Sturgeon. Habitat characterization transects were also performed at 115 and 290 feet above and 120 and 400 feet below the proposed crossing and similar conditions were present. Specific information at each transect are provided below.

Transect 1: Downstream side of proposed bridge

RDB edge of water to TOB 16 feet; LDB edge of water to TOB 8 feet (Photos 1-6)

Table 1. Physical Characterization Transect 1

Distance Interval	Substrate Composition	Water Depth (inches/feet)
RDB to 3 feet	Silt and detritus over clay	0 to 1.5 feet
3-12 feet	Sand	1.5 feet to 6 inches
12-33 feet	Sandbar	6 to 0 inches
33-55 feet	Sandbar	0 inches
55-106 feet	Sand	0 to 6 inches
106-110 feet	Sand, embedded log	6 inches to 3 feet
110-115 feet	Coarse sand with small gravel (minor component)	3 to 2.5 feet
115-119 feet	Fine sand	2.5 to 4.5 feet
119-126 feet	Clay, sand	4.5 feet
126-134 feet	Silt covered clay	4.5 feet
134-144 feet (LDB)	Detritus covered mud	4.5 feet* (sharp slope from water edge)



Photo 1. Left Descending Bank (LDB)

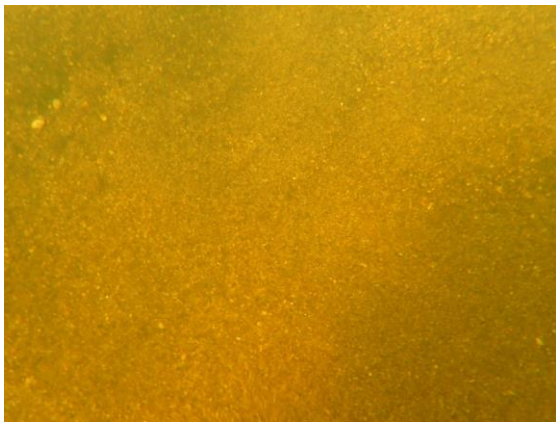

Photo 2. Gravel left of log (106')



Photo 3. Clay covered silt



Photo 4. Sandbar



Photo 5. Substrate between sandbar and Right Descending Bank (RDB).



Photo 6. Right Descending Bank

Transect 2 Center of Bridge

RDB edge of water to TOB 16 feet; LDB edge of water to TOB 8 feet (Photos 7-10)

Table 1. Physical Characterization Transect 2

Distance Interval	Substrate Composition	Water Depth (inches/feet)
RDB to 8.5 feet	Muddy clay	Dry
8.5 to 13 feet	Coarse/fine sand mix	0 to 6 to 0 inches
13 to 28.5 feet	Sandbar	Dry
28.5 to 33.5 feet	Coarse sand	0 to 10 inches
33.5 to 37 feet	Coarse sand	10 to 6 inches
37 to 53 feet	Coarse sand	6 to 10 inches
53-72 feet	Coarse sand	10 inches 10 1.5 feet
72-98 feet	Coarse Sand	1.5 to 2.0 feet
98-112 feet	Coarse sand	2.0 to 3.0 feet
112 to 119	Clay sand mix	3.0 to 1.0 feet
119 to 125 feet	Clay sand mix	1.0 to 3.0 feet
125 to 139	Clay sand mix	3.0 feet
139 to 144.5 feet (LDB)	Muddy sand covered with detritus	3.0 feet (sharp slope from water edge)



Photo 7. Left Descending Bank

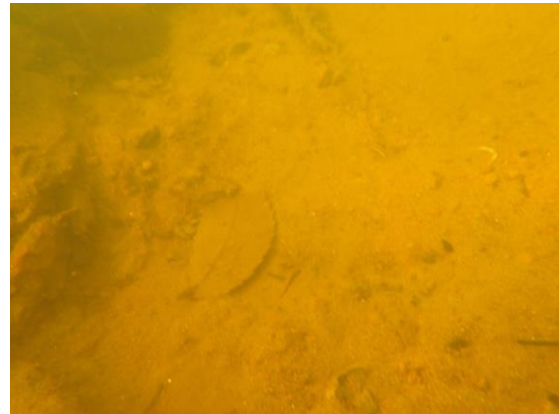

Photo 8. Clay sand



Photo 9. Muddy bank



Photo 10. Right descending bank and sand bar.

Transect 3 Upstream Side of Bridge

RDB edge of water to TOB 16 feet; LDB edge of water to TOB 18 feet (bank severely eroded) (Photos 11-13)

Table 3. Physical Characterization Transect 3

Distance Interval	Substrate Composition	Water Depth (inches/feet)
RDB to 40 feet	Silt and sand covered clay associated with large log jam	6 inches to 2.5 feet
40 to 53 feet	Coarse sand	2.5 to 3.0 feet
53 to 130 feet	Coarse sand with small gravel (minor component)	3.0 to 1 feet
130 to 136 feet	Sandy clay	1 to 2.5 feet
136 to 146 feet (LDB)	Silt covered clay	2.5 to 4.5 feet (sharp slope from water edge)



Photo 11. Log jam at RDB.



Photo 12. Log jam ~ 40' into channel



Photo 13. LDB at upstream side of bridge.

Transect 4: 115 Feet Upstream of Proposed Bridge

RDB edge of water to TOB 12 feet; LDB edge of water to TOB 16 feet (Photos 14-15)

Table 4. Physical Characterization Transect 4

Distance Interval	Substrate Composition	Water Depth (inches/feet)
RDB to 3 feet	Clay	0 to 1 foot
3.0 to 4 feet	Coarse sand with small gravel (minor)	1 to 2 feet
4.0 to 105 feet	Coarse sand with small gravel (minor component)	2 feet
105 to 120 feet (LDB)	Sandy clay	2 to 3 feet (sharp slope from water edge)



Photo 14. RDB



Photo 15. LDB

Transect 5: 290 Feet Upstream of Proposed Bridge

RDB edge of water to TOB 12 feet; LDB edge of water to TOB 10 feet (Photos 16-18)

Table 5. Physical Characterization Transect 5

Distance Interval	Substrate Composition	Water Depth (inches/feet)
RDB to 3 feet	Clay	0 to 1 foot
3.0 to 110 feet	Coarse sand	1 to 2 to 0 feet
110 to 119 feet	Sandbar	0
119 to 125 feet (LDB)	Clay with small gravel (minor component)	0 to 1 foot



Photo 16. LDB, 10' to TOB



Photo 18. RDB



Photo 17. Habitat between Transect 5 and Auburn-Knightdale Road Bridge

Transect 6: 120 Feet Downstream of Proposed Bridge

RDB edge of water to TOB 14 feet; LDB edge of water to TOB 12 feet (Photos 19)

Table 6. Physical Characterization Transect 6

Distance Interval	Substrate Composition	Water Depth (inches/feet)
RDB to 15 feet	Clay with small gravel (minor)	3 feet (sharp slope from water edge)
15 to 110 feet	Coarse sand with small gravel (minor)	3 feet to 1 foot
110 to 130 feet	Sandy clay	1 to 2 feet
130 to 140 feet (LDB)	Muddy clay	2 feet to 1 foot



Photo 19. LDB

Transect 7: 400 Feet Downstream of Proposed Bridge

RDB edge of water to TOB 16 feet; LDB edge of water to TOB 14 feet (Photos 20-21)

Table 7. Physical Characterization Transect 7

Distance Interval	Substrate Composition	Water Depth (inches/feet)
RDB to 15 feet	Clay	3 to 3.5 feet (sharp slope from water edge)
15 to 30 feet	Clay sand	3.5 feet to 1 foot
30 to 110 feet	Coarse sand	1 foot to 4 inches
110 to 130 feet (LDB)	Clay	4 inches to 1 foot



Photo 20. RDB

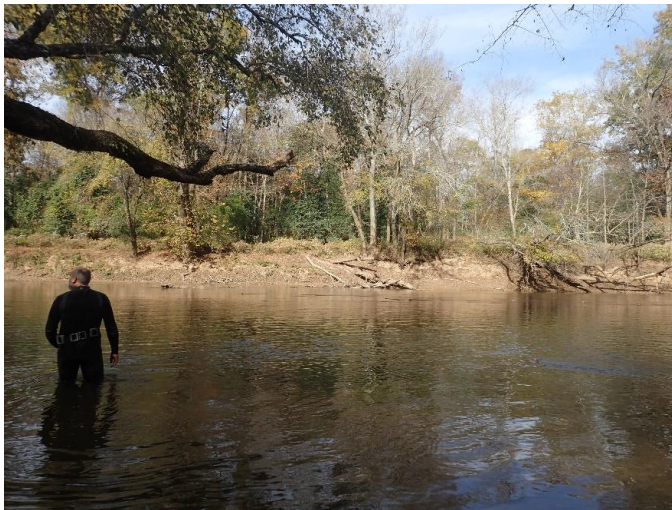

Photo 21. LDB and shallow channel

Downstream of Poole Rd: Example of potentially suitable spawning habitat (approximately 2.8 river miles above proposed crossing)



Photo 22. Riffle below Poole Rd)

Appendix C

Project Design Criteria (PDC)

Biological Assessment - Atlantic Sturgeon

General Activities

The following specific Project Design Commitments (PDCs) were developed using the Federal Highway Administration (FHWA) and National Marine Fisheries Service (NMFS) Draft Biological Programmatic Evaluation (DPBE) of the Effects of Transportation Activities and Projects Regularly Undertaken in North Carolina, South Carolina, and Georgia (NMFS 2017) as guidance. The commitments made here are the specific PDCs that will be incorporated into the design and construction of the Complete 540 project at the crossing of the Neuse River.

General PDCs Applicable to All Projects

The project will implement standard measures as part of other environmental compliance processes (e.g., USACE wetland permitting), and many of these measures reduce potential effects on listed species and critical habitat in NC. These include:

- Wetland avoidance/minimization/compensation
- Clearly delineating vegetative clearing limits; maintaining riparian buffers
- Compliance with State water quality standards through Storm Water Pollution Prevention Plans (SWPPP), which include erosion and sediment control, spill control, runoff detention, and treatment

In addition, project specific PDCs will be implemented where applicable. These PDCs are expected to reduce potential impacts of the stressors. General PDCs for this project are:

- To the maximum extent practicable, FHWA/DOTs will adhere to all relevant/applicable recommendations in the **FHWA/NMFS-SERO BMP Manual** to avoid and minimize impacts to listed species and critical habitat, and to conserve listed species and critical habitat.
- The project will adhere to the sea turtle measures in the most current version of NMFS's *Sea Turtle and Smalltooth Sawfish Construction Conditions*, which apply to this project as it is an area where Atlantic and Shortnose Sturgeon can occur. This includes the requirement that construction stops temporarily if an ESA-listed species is sighted within 50 feet of mechanical construction equipment.
- Petroleum products, chemicals, uncured concrete, or water contaminated by these will not be allowed to enter flowing waters.
- Refueling of machinery will be done at least 50 feet from any water body and be outside of active stream channels and away from ditches or channels that enter flowing waters; designated refueling sites in upland areas at least 50 feet away from receiving waters is preferred. Refueling of heavy machinery such as cranes positioned atop temporary work platforms over the water will take all relevant precautions to avoid spills into waterbodies.
- Concrete washout pits/pans/pools will be located at least 50 feet from any jurisdictional water body and be outside of active stream channels and away from ditches or channels that enter flowing waters. Designated sites in upland areas at least 50 feet away from receiving waters will be preferred.
- A Spill Plan will be created, and the plan and all materials necessary to implement the plan shall be accessible on site.
- All materials that will be placed in the Neuse Rive, including sheet piles, concrete piles, and erosion

control materials, will be pre-washed off-site or in contained upland areas to remove sediments and/or contaminants.

- Reporting of interactions with protected species:
 - Any collisions(s) and/or injuries to sturgeon occurring during the construction of a project, will be reported immediately to NMFS's Protected Resources Division (PRD) at (1-727-824-5312) or by email to takereport.nmfs@noaa.gov.
 - Dead sturgeon should be reported to 1-844-788-7491 or email nmfs.ser.sturgeonnetwork@noaa.gov
- Entanglement: All turbidity curtains and other in-water equipment will be properly secured with materials that reduce the risk of entanglement of Atlantic Sturgeon. Turbidity curtains likewise will be made of materials that reduce the risk of entanglement of Atlantic Sturgeon.
 - In-water lines (rope, chain, and cable, including the lines to secure turbidity curtains) will be stiff, taut, and non-looping. Examples of such lines are heavy metal chains or heavy cables that do not readily loop and tangle. Flexible in-water lines, such as nylon rope or any lines that could loop or tangle, will be enclosed in a plastic or rubber sleeve/tube to add rigidity and prevent the line from looping and tangling. In all instances, no excess line will be allowed in the water.
 - Turbidity curtains and other in-water equipment will be placed in a manner that does not entrap species within the construction area or block access for them to navigate around the construction area.
- Appropriate construction and inspection personnel are responsible for observing water-related activities to detect the presence of these species and avoid them. The NCDOT Division Environmental Officer will be responsible for coordinating the observation responsibilities.

Project Specific Activities

Installation, Maintenance, and Removal of Temporary Erosion, Turbidity, and Sediment Control Devices

Activity specific PDCs for the installation, maintenance, and removal of erosion, turbidity, and sediment control devices:

- Temporary erosion, turbidity, and sediment control devices are required to be installed prior to any clearing and grubbing activities, to the maximum extent practicable. In areas where clearing and grubbing is necessary to provide access and area for the installation of temporary erosion, turbidity, and sediment control devices, those devices should be installed immediately following the minimal amount of clearing and grubbing that is necessary.
- Temporary erosion, turbidity, and sediment control devices are required on all project related areas, including off-site use areas, staging areas, and in/around temporary access roads and other areas.
- All devices will be regularly inspected for effectiveness and promptly repaired or replaced if they have been damaged or are ineffective.
- All temporary devices designed to control erosion, turbidity, and sedimentation throughout the construction process will be removed immediately following project completion.
- Installation of silt/turbidity curtains will be shore-parallel (anchored on the shore at both ends); curtains must be securely anchored and will not impede or obstruct movement of listed species.

- Siltation control fence or other stationary measures will be placed parallel to the shoreline and may not be placed waterward of the MHWL or OHWM; measures will not impede or obstruct movement of listed species.

Staging Areas

Activity specific PDCs for staging areas:

- Staging areas will be located in upland areas and have appropriate temporary erosion, turbidity, and sediment controls, including, but not limited to stabilized construction exists/entrances and sediment control fence.
- Staging areas will not be located in active channels (e.g., streams, tidal creek creeks, or rivers) or open water areas and will not be located in tidal areas (e.g., all staging areas will be located above MHWL); staging areas shall be setback a minimum of 15 feet from the OHWM and MHWL.
- Staging area activities will not impede or obstruct movement of listed species.

Site Preparation

Activity specific PDCs for site preparation activities:

- To the maximum extent practicable, site preparation (e.g., earthwork, obstruction removal) will begin following installation of temporary erosion, turbidity, and sedimentation control measures, including perimeter sediment control fence.
- In areas where ESA-listed species are present, riparian and shoreline vegetation will not be cleared, trimmed, or otherwise altered if the area is not essential for project construction or facilitation of construction.
- Site preparation will not impede or obstruct movement of listed species during the August 15 to October 31 moratorium.

Geotechnical Drilling and Hazardous Waste Sampling

Activity specific PDCs for geotechnical drilling and hazardous waste sampling activities:

- Drilling in aquatic or wetland areas will occur from existing structures (e.g., bridges, temporary work trestles, or temporary causeways), barges, vessels, or low ground bearing pressure tracked rigs.
- Drilling and sampling will be timed to avoid the presence of sturgeon to the extent practicable; drilling and sampling will not impede or obstruct movement of listed species.

Temporary Platforms, Access Fills (including rock/rip rap jetties), and Cofferdams

Activity specific PDCs for temporary platforms, access fills, and cofferdam activities:

- Geotextile barriers will be installed prior to placement of access fills to ensure that the fill will be removed completely at the end of construction as practicable as possible.
- Temporary fill materials will be placed in a manner that will not be eroded by high water flows. Following the removal of temporary fills, the channel will still allow Sturgeon passage in the

event that they are present.

- The navigability of the waterway will remain uninterrupted and freely open for vessel traffic and/or species movement in the area.
 - Cofferdams and fills will be limited to no more than 50% of the width of a waterbody at one time.
- Appropriate measures will be taken to maintain normal downstream flows and minimize flooding to the maximum extent practicable, when temporary structures, work and discharges, including cofferdams, are necessary for construction activities, access fills, or dewatering of the construction sites.
- For temporary inflatable cofferdams, the footprints of the walls will be included into the overall impacts area.

Pile Installation and Removal

Activity specific PDCs for pile installation and removal activities:

- Pile installation (both in-water and “in the dry” [behind cofferdam]), will take place only during daylight hours.
- Where appropriate, silt or turbidity curtains will be used to reduce the impact of suspended sediments and potential for siltation/sedimentation of adjacent habitats.
- Water jetting will be avoided in areas with fine sediments to reduce turbidity plumes and the release of nutrients and contaminants. If jetting is necessary, silt curtains will be used.

Equipment

General equipment associated with roadway construction includes, but is not limited to, pick-up trucks, dump trucks, front-end loaders, cranes, asphalt grinders, paving machines, compaction rollers, bulldozers, chainsaws, vibratory and impact pile drivers, barges, vessels (boats), explosives, excavators, hoe rams, rock crusher (if blasting is used for on-site fill) track or pneumatic drills, graders, jack hammers, stingers, wire saws, air compressors, traffic control devices, generators, and other heavy equipment.

Activity specific PDCs for equipment:

- Equipment will only be used for its primary/intended purpose.
- All equipment will be checked daily for leaks; all equipment will have, at a minimum, 1 spill kit on/attached.
- Equipment will not be used until leaks, or other maintenance issues, are repaired or new equipment is brought into for replacement.
- All equipment maintenance and other work that may release pollutants/toxicants will occur in contained maintenance areas at least 50 feet from any water body and be outside of active stream channels, outside of any tidal areas, and away from ditches or channels that enter flowing waters.
- Heavy equipment such as excavators, cranes, and bulldozers will not be located in the water to conduct work; buckets or extensions may be reached into the water from atop the bank/platform/trestle to conduct work.
- Drilling equipment, such as low ground bearing pressure tracked rigs, may be used in-water, but not in the main channel of streams, creeks, or rivers, and must be in-water for the least amount of time necessary to complete work.

- Vessels shall operate at “no wake/idle” speeds

Appendix D

Riparian Buffer Reforestation Detail

Biological Assessment - Atlantic Sturgeon

REFORESTATION:

Description

Reforestation will be planted in areas as directed. *Reforestation* is not shown on the plan sheets. See the Reforestation Detail Sheet.

All non-maintained riparian buffers impacted by the placement of temporary fill or clearing activities shall be restored to the preconstruction contours and revegetated with native woody species.

The entire *Reforestation* operation shall comply with the requirements of Section 1670 of the *Standard Specifications*.

Materials

Reforestation shall be bare root seedlings 12"-18" tall.

Construction Methods

Reforestation shall be planted as soon as practical following permanent *Seeding and Mulching*. The seedlings shall be planted in a 16-foot wide swath adjacent to mowing pattern line, or as directed.

Root dip: The roots of reforestation seedlings shall be coated with a slurry of water, and either a fine clay (kaolin) or a superabsorbent that is designated as a bare root dip. The type, mixture ratio, method of application, and the time of application shall be submitted to the Engineer for approval.

With the approval of the Engineer, seedlings may be coated before delivery to the job or at the time of planting, but at no time shall the roots of the seedlings be allowed to dry out. The roots shall be moistened immediately prior to planting.

Seasonal Limitations: *Reforestation* shall be planted from November 15 through March 15.

Measurement and Payment

Reforestation will be measured and paid for in accordance with Article 1670-17 of the *Standard Specifications*.

PLANTING DETAILS

SEEDLING / LINER BAREROOT PLANTING DETAIL

HEALING IN

1. Locate a healing-in site in a shady, well protected area.
2. Excavate a flat bottom trench 12 inches deep and provide drainage.

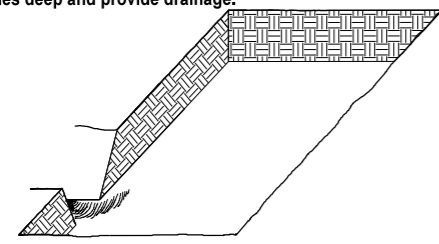

3. Backfill the trench with 2 inches well rotted sawdust. Place a 2 inch layer of well rotted sawdust at a sloping angle at one end of the trench.

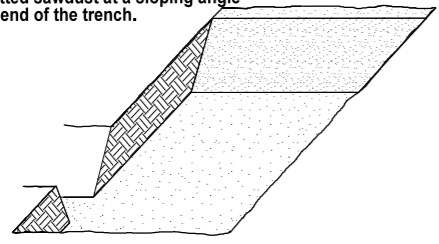

4. Place a single layer of plants against the sloping end so that the root collar is at ground level.

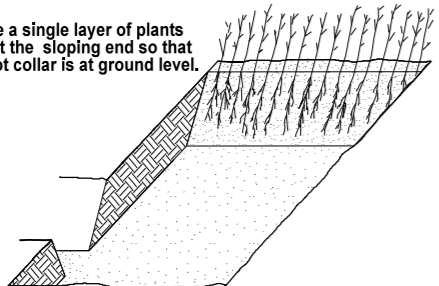

5. Place a 2 inch layer of well rotted sawdust over the roots maintaining a sloping angle.

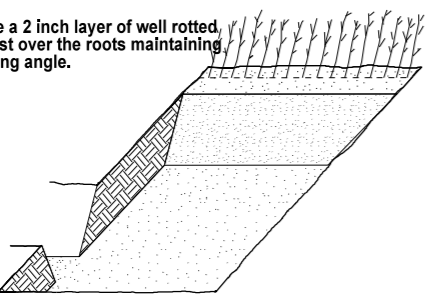

6. Repeat layers of plants and sawdust as necessary and water thoroughly.

DIBBLE PLANTING METHOD USING THE KBC PLANTING BAR

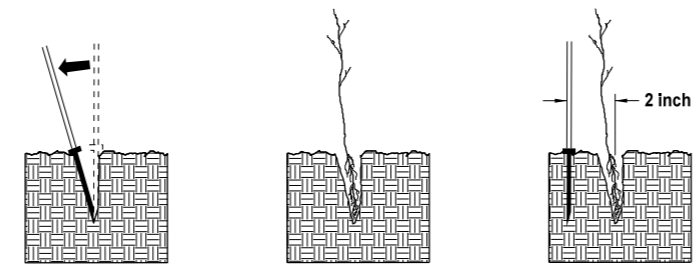

1. Insert planting bar as shown and pull handle toward planter.
2. Remove planting bar and place seedling at correct depth.
3. Insert planting bar 2 inches toward planter from seedling.

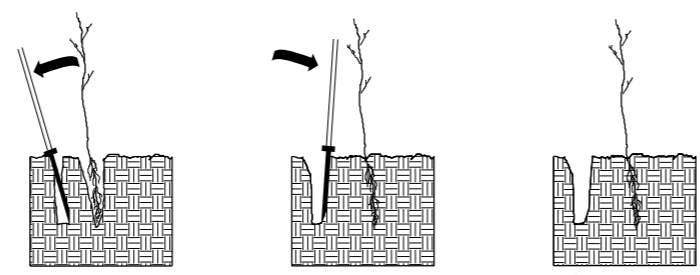

4. Pull handle of bar toward planter, firming soil at bottom.
5. Push handle forward firming soil at top.
6. Leave compaction hole open. Water thoroughly.

PLANTING NOTES:

PLANTING BAG
During planting, seedlings shall be kept in a moist canvas bag or similar container to prevent the root systems from drying.



KBC PLANTING BAR
Planting bar shall have a blade with a triangular cross section, and shall be 12 inches long, 4 inches wide and 1 inch thick at center.



ROOT PRUNING
All seedlings shall be root pruned, if necessary, so that no roots extend more than 10 inches below the root collar.

REFORESTATION

- TREE REFORESTATION SHALL BE PLANTED 6 FT. TO 10 FT. ON CENTER, RANDOM SPACING, AVERAGING 8 FT. ON CENTER, APPROXIMATELY 680 PLANTS PER ACRE.

REFORESTATION

MIXTURE, TYPE, SIZE, AND FURNISH SHALL CONFORM TO THE FOLLOWING:

25% PLATANUS OCCIDENTALIS	AMERICAN SYCAMORE	12 in - 18 in BR
25% LIRIODENDRON TULIPIFERA	YELLOW POPLAR	12 in - 18 in BR
25% FRAXINUS PENNSYLVANICA	GREEN ASH	12 in - 18 in BR
25% QUERCUS ALBA	WHITE OAK	12 in - 18 in BR